

460" FORD, LINCOLN & MERCURY V8

IDENTIFICATION CODING

ENGINE IDENTIFICATION

Engine may be identified from the official Vehicle Identification Number. Number is stamped on a metal tab fastened to instrument panel close to windshield on driver's side of car and visible from outside. The Identification Number contains eleven digits. Example: 7F87A100001. The first digit determines model year and fifth digit establishes engine identification.

Engine	Code
460"	A
460" Police	C

ENGINE REMOVAL

See *Engine Removal at end of ENGINE Section.*

CYLINDER HEAD & MANIFOLDS

INTAKE MANIFOLD

Removal - 1) Drain cooling system. Remove air and intake duct assembly. Disconnect radiator upper hose at engine, heater hoses at intake manifold and water pump.

2) Disconnect all vacuum lines and wires (remove distributor cap and wires as an assembly), then remove distributor. Disconnect and remove coil, fuel line, accelerator linkage, and Thermactor by-pass valve and hose. Remove intake manifold and carburetor as an assembly.

Installation - 1) Apply suitable oil resistant sealer at four junction points of seals and gaskets. Position front and rear seals on cylinder block and new gaskets on heads. Make sure that holes in gaskets are aligned with holes in cylinder head.

2) Lower manifold on engine and check for correct positioning of gaskets and seals before installing bolts. Install bolts and tighten in two steps in sequence (see Fig. 1).

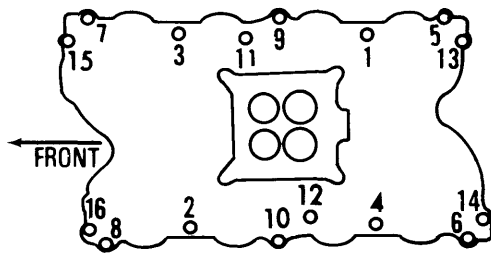

Fig. 1 Intake Manifold Tightening Sequence

CYLINDER HEAD

Removal - 1) Remove intake manifold and carburetor as an assembly. Disconnect exhaust pipes from manifold. If equipped with A/C, disconnect valves and hoses at compressor; remove compressor brackets attached to cylinder head and water pump; position compressor out of way.

2) Position alternator, power steering pump and brackets out of way. Remove rocker arm covers, rocker arms and push rods, keeping in sequence for installation. Remove cylinder head bolts and lift cylinder heads and exhaust manifolds, as an assembly, from engine.

Installation - 1) Clean old gasket material from cylinder head and block. Position head gasket on block and install cylinder head. **NOTE** - Do not use sealer on head gasket surfaces.

2) Install bolts (two longer bolts in lower rear holes of left cylinder head and one long bolt in lower rear hole of right cylinder head) and tighten in three steps, in sequence (see Fig. 2).

Cylinder Head Tightening Specifications

Step	Ft. Lbs.
1.....	70-80
2.....	100-110
3.....	130-140

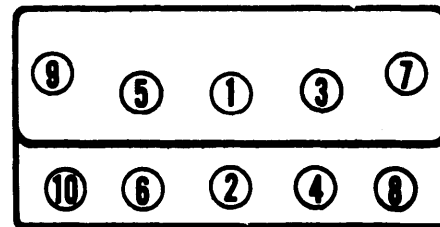

Fig. 2 Cylinder Head Tightening Sequence

VALVES

VALVE ARRANGEMENT

E-I-E-I-E-I-E-I (Left bank, front to rear).
I-E-I-E-I-E-I-E (Right bank, front to rear).

VALVE GUIDE SERVICING

To ream guides for installation of valves with oversize stems, always use reamers in sequence and always reface valve seat after valve guide is reamed. Reamers are available .003" oversize with standard size pilot; .015" oversize reamer with .003" oversize pilot; .030" oversize reamer with .015" oversize pilot.

VALVE STEM OIL SEALS

Cup or umbrella type seals used on all valves. Install seals with cup side down.

VALVE SPRINGS

Removal - 1) Remove rocker arm cover and spark plug on cylinder to be serviced. Install air line with adapter in spark plug hole. **NOTE** - If air pressure fails to hold valve closed, remove cylinder head for inspection of valve seat.

2) Remove required rocker arms and push rods. Use suitable spring compression tool to compress valve and remove retainer locks, spring retainer and valve spring. Remove and discard valve stem seal. Do not remove air pressure as this will allow valve to fall into cylinder if piston is at bottom of cylinder.

Installation - Lubricate valve stem with engine oil and install new valve stem seal. Place spring in position over valve and install spring retainer. Compress valve spring and install locks.

460" FORD, LINCOLN & MERCURY V8 (Cont.)

Apply Lubriplate to ends of push rods and tip of valve stem. Install rocker arms, spark plug and tighten.

VALVE SPRING INSTALLED HEIGHT

Spring ends must be square within $\frac{5}{64}$ ". Installed height of valve spring must not exceed specifications. Measure height from surface of cylinder head pad to underside of spring retainer. If height is greater than specified ($1\frac{3}{4}$ "- $1\frac{5}{64}$ "), install .030" spacer on head under spring to bring height within limits. **CAUTION** — Do not install spacers unless necessary.

ROCKER ARM ASSEMBLY

Rocker arms are individually mounted with fulcrum bolts which are threaded into cylinder head. Before installing, apply Lubriplate or equivalent to top of valve stem, rocker arm and fulcrum seat.

HYDRAULIC VALVE LIFTER ASSEMBLY

Each lifter is a matched assembly and parts are not interchangeable. Keep lifter assemblies in proper sequence for reinstallation in original location. If lifters are disassembled for inspection, after reassembly use a suitable leak down rate tester following manufacturer's instructions. Leak down rate on all lifters should be 5-50 seconds at $\frac{1}{16}$ " plunger travel under a 50 pound load.

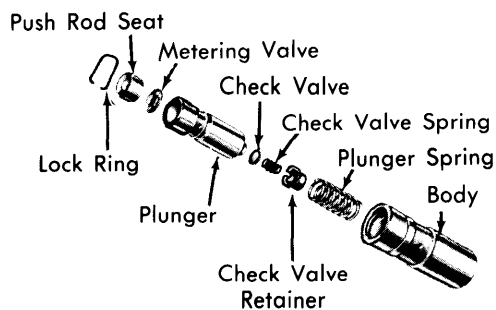

Fig. 3 Exploded View of Hydraulic Valve Lifter Assembly

HYDRAULIC VALVE LIFTER ADJUSTMENT

Repeated valve seat and face reconditioning operations will decrease valve stem to rocker arm clearance to point that if compensation is not made, valve lifters will cease to function.

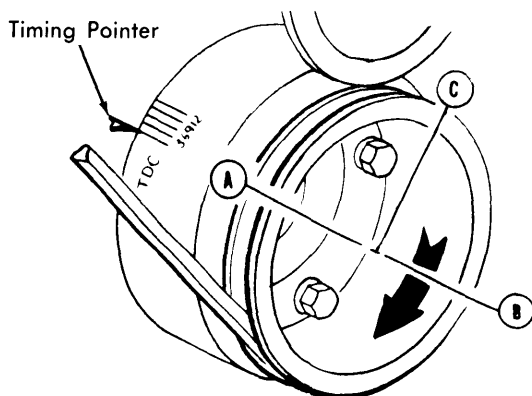

Fig. 4 Positions For Checking Valve Clearance

To compensate for any dimensional changes in valve mechanism, a .060" shorter or .060" longer replacement push rod is available. Valve clearance should be .075-.175" with valve lifter completely collapsed. Use suitable tool (T71P-6513-A) and slowly collapse valve lifter until plunger is bottomed. Hold lifter down while checking valve clearance as follows:

1) Rotate crankshaft until No. 1 piston is at TDC (point "A") after compression stroke as indicated by timing mark on crankshaft damper and pointer (see illustration). Make a chalk mark on damper 180° (point "B") from TDC mark. Make chalk mark on damper 90° (point "C") clockwise from TDC mark.

2) With damper at position "A", check the following valves:

Intake No. 1-7-8. Exhaust No. 1-5-4.

3) Rotate crankshaft 180° (1/2 turn) clockwise from position "A" so that position "B" is opposite pointer. Check the following valves:

Intake No. 5-4. Exhaust No. 2-6.

4) Rotate crankshaft 270° (3/4 turn) clockwise from position "B" so that position "C" is opposite pointer. Check the following valves:

Intake No. 2-3-6. Exhaust No. 3-7-8.

PISTONS, PINS & RINGS

OIL PAN

See Oil Pan Removal at end of ENGINE Section.

PISTON & ROD ASSEMBLY

NOTE — New pistons must be installed in same cylinders for which they were fitted and used pistons in same cylinder from which they were removed.

Removal — With cylinder head and oil pan removed, use a suitable ridge cutter to remove any ridge or deposits on upper end of cylinder bore. **NOTE** — Piston must be at bottom of stroke and covered with cloth to collect cuttings. Inspect connecting rods and caps for cylinder identification and mark as necessary. Remove rod cap and push piston and rod assembly out top of cylinder block taking care not to nick crankshaft journal or cylinder wall.

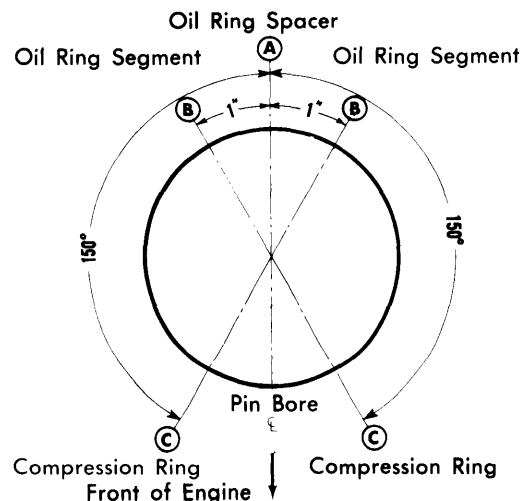

Fig. 5 Piston Ring Gap Spacing

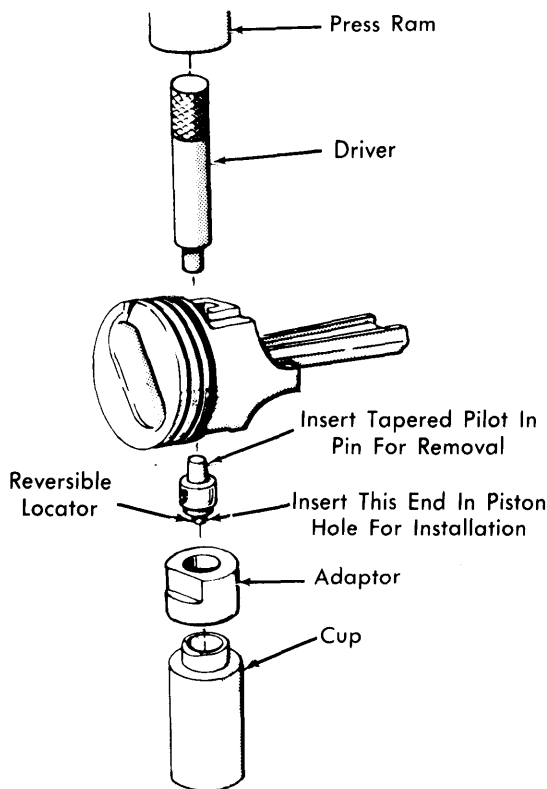

Fig. 6 Piston Pin Replacement

Installation – 1) Lightly coat cylinder bores, pistons and rings with engine oil. Ensure that ring gaps are properly spaced (see Fig. 5) and install ring compressor on piston.

2) Install each piston and rod assembly (with notch on piston head facing front of engine) in its respective bore. Guide connecting rod onto crankshaft journal while tapping piston head with hammer handle to seat connecting rod against crankshaft. Install rod caps and tighten.

FITTING PISTONS

Measure piston at centerline of piston bore 90° to pin bore axis. Measure cylinder bore at right angles to centerline of crankshaft, below ring travel. Piston clearance must be within specifications.

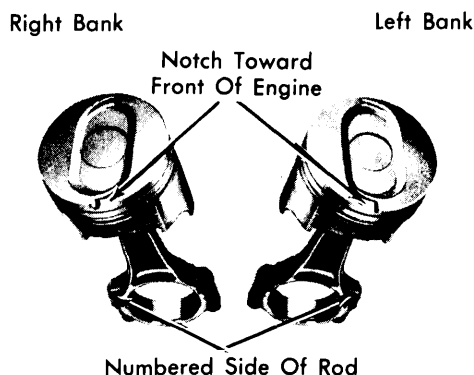

Fig. 7 Piston & Rod Assembly Installation

PISTON PINS

Pins are a press fit in connecting rod. Use suitable tool and arbor press for removal and installation (see Fig. 6). When installed, end of pin must be $\frac{1}{16}$ " to $\frac{1}{8}$ " below chamfer of pin bore in piston.

CRANKSHAFT & ROD BEARINGS

MAIN & CONNECTING ROD BEARINGS

NOTE – The following procedures are performed with oil pan removed.

Removal – Remove connecting rod cap after ensuring caps are marked for identification to rod assembly. Use suitable tool (6331) in oil hole of crankshaft to remove upper half of main bearing by rotating crankshaft in direction of engine rotation. Replace main bearings one at a time.

Installation – 1) Determine crankshaft journal clearance in bearing using Plastigage method. Place a jack under counterweight adjoining bearing being checked so weight of crankshaft will not compress Plastigage and provide an erroneous reading.

2) If bearing clearance is excessive, a .001" or .002" undersize bearing half may be used in combination with a standard size bearing half. If .002" undersize bearings are used on more than one journal, they may be positioned in cylinder block rather than bearing cap.

3) If standard and .002" undersize combination do not bring bearing clearance within specified limits, crankshaft will have to be refinished and undersize bearings installed.

THRUST BEARING ALIGNMENT

Install all bearing caps except thrust bearing cap and tighten. Install thrust bearing cap with bolts finger tight. Pry crankshaft to front of engine and hold forward while prying thrust bearing cap to rear. Hold crankshaft forward and tighten bolts on thrust bearing cap. Check crankshaft end play.

REAR MAIN BEARING OIL SEAL

Split, lip-type seal may be installed (upper and lower halves) without removing crankshaft from engine. Proceed as follows:

1) Loosen all main bearing cap bolts, allowing crankshaft to drop (not more than $\frac{1}{32}$ ") and remove rear main bearing cap. Remove oil seal from cap and clean oil seal groove.

2) Remove upper seal half from block using seal removal tool or small metal screw in end of seal. **CAUTION** – Extreme care should be taken not to scratch or mar crankshaft seal surface.

3) Dip upper and lower halves of new seal in engine oil. Remove oil seal retaining pin from bearing cap and discard. Pin is not used with lip-type seal. Install upper seal half in cylinder block so that $\frac{3}{8}$ " protrudes below parting surface.

4) Tighten bearing cap. Install lower half of seal in rear main cap so $\frac{3}{8}$ " protrudes above parting surface. Apply light coat of oil resistant sealer to rear of top mating surface of bearing cap. Install cap and tighten.

CAMSHAFT

ENGINE FRONT COVER

Removal – 1) **NOTE** – Replace front seal whenever cover is removed. Drain cooling system and crankcase. Remove

460" FORD, LINCOLN & MERCURY V8 (Cont.)

radiator shroud and fan, then disconnect oil cooler lines at radiator and all radiator hoses.

2) Remove radiator. Remove drive belts and water pump pulley. Remove A/C compressor support bracket, crankshaft pulley and crankshaft damper. Disconnect fuel lines and remove fuel pump.

3) Remove front cover attaching bolts, pull cover forward slightly and cut oil pan seal flush with cylinder block. Remove front cover and water pump as an assembly.

Installation - 1) Clean all gasket surfaces, then cut and position required sections of a new seal on oil pan and install suitable sealer at corners. Coat gasket surfaces of block and cover with suitable sealer and position a new gasket on block.

2) Position cover on cylinder block and use suitable tool (T61P-6019-B) to align front cover. Coat threads of attaching bolts with oil-resistant sealer and install to front cover. Tighten all bolts.

FRONT COVER OIL SEAL

Drive out old seal with pin punch and clean seal recess. Coat new seal with grease and use suitable tool (T68P-6700-A) to install. After installation, be sure seal spring is in proper position.

TIMING CHAIN

Removal - 1) With front cover removed, check deflection of timing chain before removing. If deflection exceeds specifications (.500") replace timing chain.

2) Crank engine until timing marks are lined up (see Fig. 8) and remove camshaft sprocket cap screw, washer and fuel pump eccentric. Slide timing chain and sprockets forward and remove as an assembly.

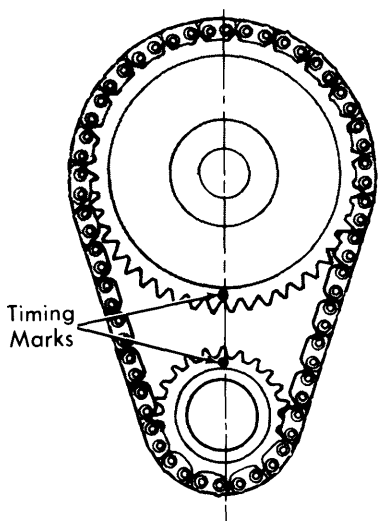

Fig. 8 Timing Chain Sprocket Alignment

Installation - 1) Assemble timing chain and sprockets so sprocket timing marks point directly toward each other and install chain and sprockets as an assembly to crankshaft and camshaft.

2) Recheck alignment of timing marks, lubricate timing chain with engine oil and install fuel pump eccentric, washer and sprocket screw.

CAMSHAFT

Removal - 1) Remove timing chain, sprockets, intake manifold, and rocker arm covers. Loosen rocker arm stud bolts. Remove push rods and valve lifters.

2) Remove A/C condenser (do not disconnect lines), grille, and camshaft thrust plate attaching bolts. Remove camshaft being careful not to damage camshaft bearings.

Installation - Oil journals and apply Lubriplate to cam lobes. Carefully slide camshaft into position.

CAMSHAFT BEARINGS

Removal & Installation - 1) With camshaft, flywheel and crankshaft removed from engine, push pistons to top of cylinders. Remove camshaft rear bearing bore plug. Using suitable driver-puller tool, remove bearings.

2) When installing new bearings, oil holes in bearings must be aligned with oil holes in cylinder block. Front bearing must be installed specified distance below front face of cylinder block (.04-.06").

CAMSHAFT END THRUST

Rocker arm stud bolts must be loosened sufficiently to free camshaft. Push camshaft toward rear of engine and install dial indicator so point is on camshaft sprocket attaching bolt. Zero indicator. Position screwdriver between camshaft sprocket or gear and block, pull camshaft forward and release. If end play is excessive, replace thrust plate. **CAUTION** - Do not attempt to pry camshaft back and forth with valve train load on camshaft.

CAM LOBE LIFT

Check lift of each camshaft lobe in consecutive order as follows:

1) Remove rocker arms and make sure each push rod is in valve lifter socket. Install dial indicator so ball socket adapter of indicator rests on end of push rod and in same plane as push rod movement. With an auxiliary starter switch connected to starter solenoid and ignition switch "OFF", bump crankshaft until tappet is on base circle of camshaft lobe (push rods lowest point).

2) Zero dial indicator and continue to rotate crankshaft until push rod is in fully raised position (highest indicator reading). Compare total lift from indicator readings with specifications. If lift on any lobe is .005" less than specifications, valve lifters are operating on worn lobes.

ENGINE OILING

Crankcase Capacity - 4 qts., add 1 qt. with filter change (except Police). 6 qts., add 1 qt. with filter change (Police).

Oil Filter - Change oil filter at first oil change and every second oil change after that.

Normal Oil Pressure - 40-65 psi @ 2000 RPM.

Pressure Regulator Valve - In oil pump body. Not adjustable.

Ford Motor Co. V8 Engines

460" FORD, LINCOLN & MERCURY V8 (Cont.)

ENGINE OILING SYSTEM

Crankshaft & Camshaft Bearings – Lubricated through vertical passages from main oil gallery, which is fed directly from oil filter.

Rocker Arms, Push Rods & Valves – Engine feeds oil through hydraulic valve lifters and hollow push rods to rocker arms and upper valve train area.

Timing Chain & Sprockets – Lubricated by drainings from No. 1 camshaft bearing.

threading sheet metal screw into oil pressure relief valve plug and remove plug. Remove spring and relief valve.

Reassembly – Clean, inspect (see specifications) and oil all parts. Install relief valve, spring and plug in oil pump housing. Press plug inward until it seats and install cotter pin. Install outer rotor and rotor shaft assembly. **NOTE** – Identification mark on outer rotor must be on same side as mark on rotor shaft assembly. These parts are matched sets and can only be replaced as an assembly. Install cover and tighten bolts. Fill housing with engine oil for priming purposes.

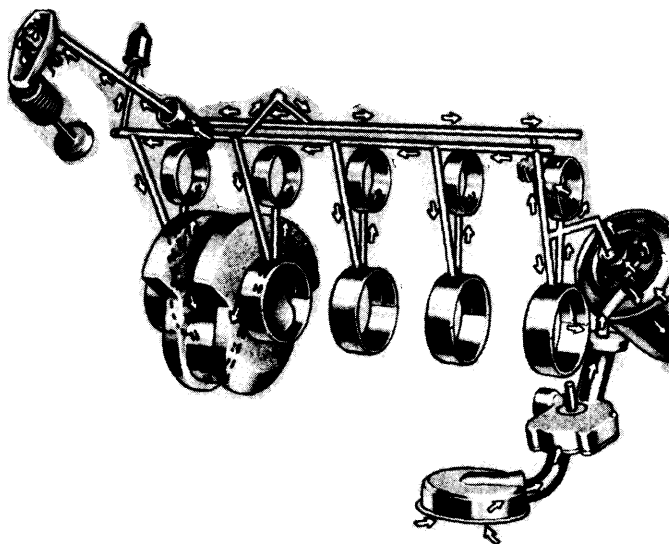

Fig. 9 Engine Oiling System

Oil Pump Specifications

Outer Race-to-Housing Clearance	.001-.013"
Rotor End Clearance	.004" Max.
Shaft-to-Housing Clearance	.0015-.0030"
Relief Valve-to-Bore Clearance	.0015-.0030"
Relief Valve Spring Pressure	20.6-22.6 @ 2.49"

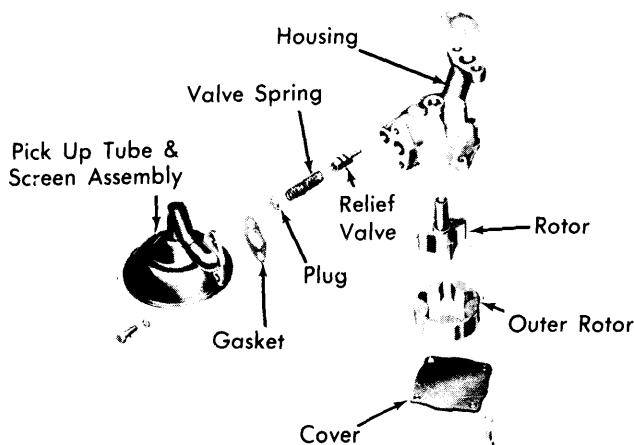

Fig. 10 Oil Pump Assembly

OIL PUMP

Disassembly – Remove cover screws and cover from pump. Remove outer rotor and rotor shaft assembly. Remove cotter key securing relief valve plug. Drill a small hole and insert self-

ENGINE SPECIFICATIONS

GENERAL SPECIFICATIONS						
Engine	Net HP At RPM	Torque (Ft. Lbs. at RPM)	Compr. Ratio	Bore	Stroke	Displ. Cu. Ins.
460"	197 @4000	353 @2000	8.0-1	4.36"	3.85"	460

VALVES							
Engine & Valve	Head Diam.	Face Angle	Seat Angle	Seat Width	Stem Diameter	Stem Clearance	Valve Lift
460"							
Int.	2.082"	44°	45°	.060-.080"	.342"	.001-.0027"	.437"
Exh.	1.653"	44°	45°	.060-.080"	.342"	.001-.0027"	.481"

Ford Motor Co. V8 Engines

6-69

460" FORD, LINCOLN & MERCURY V8 (Cont.)

ENGINE SPECIFICATIONS (Cont.)

VALVE SPRINGS			
Engine	Free Length	PRESSURE (LBS.)	
		Valve Closed	Valve Open
460"	2.07"	76-84 @ 1.81"	218-240 @ 1.33"
460" P.I.	2.07"	87-97 @ 1.82"	300-330 @ 1.32"

CAMSHAFT			
Engine	Journal Diam.	Clearance	Lobe Lift
460"	2.1243"	.001-.003"	Int. .253" Exh. .278"
460" P.I.	2.1243"	.001-.003"	Int. .289" Exh. .289"

PISTONS, PINS, RINGS						
Engine	PISTONS ① Clearance	PINS		RINGS		
		Piston Fit	Rod Fit	Rings	End Gap	Side Clearance
460"	.0014-.0022"	.0002-.0004"	Press Fit	Comp. Oil	.010-.020" .015-.055"	.0025-.0045" Snug
460" P.I.	.0022-.0030"	.0002-.0004"	Press Fit	Comp. Oil	.010-.020" .015-.055"	.0025-.0045" Snug

① — Measured at piston pin bore centerline 90° to bore.

CRANKSHAFT MAIN & CONNECTING ROD BEARINGS							
Engine	MAIN BEARINGS				CONNECTING ROD BEARINGS		
	Journal Diam.	Clearance	Thrust Bearing	Crankshaft Endplay	Journal Diam.	Clearance	Sideplay
460"	2.9994-3.0002"	.0008-.0015"	No. 3	.004-.008"	2.4992-2.5000"	.0008-.0015"	.010-.020"
460" P.I.	2.9994-3.0002"	.0008-.0015"	No. 3	.004-.008"	2.4992-2.5000"	.0008-.0015"	.010-.020"

TIGHTENING SPECIFICATIONS

Application	Ft. Lbs.
Camshaft Sprocket	40-45
Camshaft Thrust Plate	9-12
Connecting Rod Caps	40-45
Cylinder Head	①
Damper-to-Crankshaft	70-90
Exhaust Manifold	28-33
Flywheel	75-85
Front Cover	12-18
Fuel Pump	19-27
Intake Manifold	22-32
Main Bearing Caps	95-105
Pulley-to-Damper	35-50
Oil Pan	② 9-11
Rocker Arm Stud or Bolt	18-25

① — See Cylinder Head Installation.

② — ¼" bolts torque to 7-9 ft. lbs.