

304" & 360" V8

IDENTIFICATION CODING

ENGINE IDENTIFICATION

Numbers indicating CID are cast into sides of cylinder block between engine mounting bracket bosses. Engine code number is located on tag attached to valve cover, right bank. Letter contained in code number designates CID, carburetor and compression ratio. Coding is as follows:

Code	CID	Carb.	Comp. Ratio
H.....	304.....	2-Bbl.....	8.4-1
N.....	360.....	2-Bbl.....	8.25-1

SPECIAL ENGINE MARKINGS

Some engines are produced with oversize or undersize components. This is indicated by letters stamped adjacent engine code number. Coding is as follows:

- B** - All cylinder bores .010" oversize.
- M** - All main bearings .010" undersize.
- P** - All connecting rod bearings .010" undersize.
- PM** - All connecting rod and main bearings .010" undersize.
- C** - All camshaft bearing bores .010" oversize.

ENGINE REMOVAL

See *Engine Removal* at end of *ENGINE* Section.

CYLINDER HEAD & MANIFOLDS

INTAKE MANIFOLD

Removal - 1) Drain cooling system and remove air cleaner. Disconnect spark plug wires, upper radiator hose and bypass hose from manifold. Disconnect ignition coil bracket and position to one side.

2) Remove TCS solenoid vacuum valve and solenoid control switch. Disconnect all hoses, lines, linkage and wires from carburetor and intake manifold. Disconnect air delivery hoses at air injection manifold.

3) Disconnect diverter valve from air pump output hose. Remove carburetor. Remove intake manifold, gasket and end seals.

Installation - 1) Clean all gasket mating surfaces. Apply suitable sealing compound to both sides of new gasket. Position gasket by aligning two rear locators at rear of cylinder head. Then, holding rear in place, align two front locators.

2) Install two end seals and apply sealing compound to seal ends. Install intake manifold, retaining bolts and tighten bolts. Reverse removal procedure to complete assembly.

CYLINDER HEAD

Removal - 1) Drain cooling system and remove rocker arm cover, rocker arm assemblies and push rods. **NOTE** - Loosen cap screws alternately one turn at a time to avoid breaking bridge. Keep rocker arm assemblies and push rods in same order as removed.

2) Remove spark plugs, intake and exhaust manifolds. Loosen all drive belts and remove compressor mount bracket. Remove battery negative cable from cylinder head.

3) Disconnect alternator support brace, power steering pump and air pump. Remove cylinder head retaining bolts. Remove cylinder head and gasket.

Installation - 1) Clean all gasket surfaces. Apply thin coat of suitable sealing compound to both sides of head gaskets.

NOTE - Do not apply sealing compound to head and block surfaces or allow sealer to enter cylinder bores.

2) Position gasket on block with word "TOP" facing up. Install cylinder head and retaining bolts. Tighten bolts in sequence (see Fig. 1).

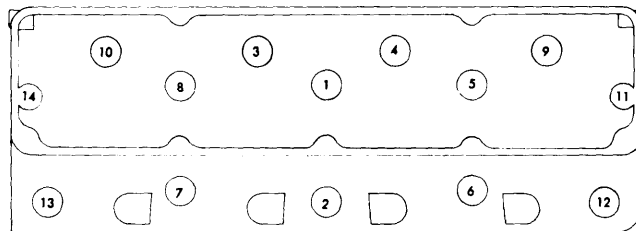

Fig. 1 Cylinder Head Tightening Sequence

VALVES

VALVE ARRANGEMENT

All - E-I-I-E-E-I-I-E (front to rear, both banks).

VALVE GUIDE SERVICING

Guides are integral part of cylinder head. If valve stem clearance becomes excessive due to guide wear, guides must be reamed to next oversize, and oversize valves installed. Oversize valves are available in .003", .015" and .030" oversize. Valve guide reamers are available for these oversizes.

NOTE - Guides must be reamed in steps, starting with .003" oversize reamer and progressing to size desired.

VALVE STEM OIL SEALS

Nylon valve stem seals are used on each valve stem and should be replaced whenever seals become deteriorated or valve service is performed.

VALVE SPRINGS

Removal - 1) Remove rocker arm cover, rocker arm assemblies and push rods. **NOTE** - Retain rocker arm assemblies and push rods in order for reinstallation in original location.

2) Remove spark plug on cylinder to be serviced and install suitable air line adaptor to spark plug port. Apply air pressure to hold valves in place.

3) Using suitable tool (J-22534) or equivalent, compress valve spring and remove valve locks. Remove valve spring and retainer and remove valve oil seal.

Installation - 1) Use suitable valve spring tester (J-8056) to test valve springs. Replace springs that are not within specifications.

304" & 360" (Cont.)

2) Reverse removal procedures while noting the following: Valve springs must be installed with closed coil end facing cylinder head. Do not overcompress spring upon installation as oil deflector may be damaged. Push rods and rocker arm assemblies must be reinstalled in original locations.

ROCKER ARM ASSEMBLY

Intake and exhaust rocker arms of each cylinder pivot on a bridged pivot assembly which is secured to cylinder head by two capscrews.

HYDRAULIC VALVE LIFTER ASSEMBLY

1) Lifters are serviced as complete assemblies only and parts are not interchangeable between lifters. Inspect for signs of scuffing on barrel and face of lifter body.

2) Inspect lifter face for concave wear and if present, replacement of camshaft and lifters is necessary. If lifters are disassembled for cleaning and inspection, after reassembly (see Fig. 2), they should be tested using suitable leak down tester according to manufacturer's instructions.

3) Discard lifters not within specifications. **NOTE** — Do not fill lifter assemblies with engine oil prior to installation as they will charge themselves with 3 to 8 minutes of engine operation.

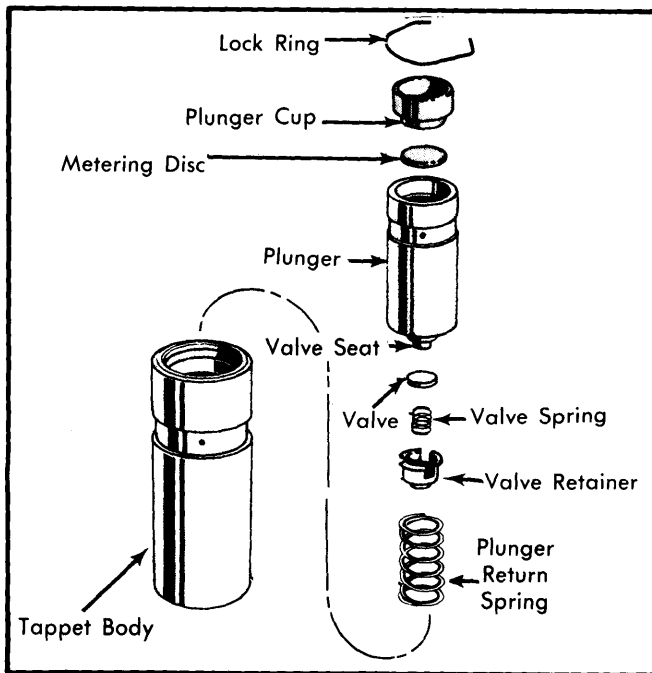

Fig. 2 Hydraulic Valve Lifter Assembly

PISTONS, PINS & RINGS**OIL PAN**

See Oil Pan Removal at end of ENGINE Section.

PISTON & ROD ASSEMBLY

Removal — 1) With cylinder and oil pan removed, use a suitable ridge reamer to remove any ridge or deposits on up-

per end of cylinder bore. **NOTE** — Piston must be at bottom of stroke and covered with cloth to collect cuttings.

2) Remove connecting rod bearing caps and retain in same order as removed. **NOTE** — Caps and rods are stamped with corresponding cylinder number.

3) Cover connecting rod studs to protect cylinder walls and push piston and rod assembly out top of cylinder block.

Installation — 1) Piston rings must be positioned as follows: Oil spacer gap on centerline within 20° of either skirt face. Oil rail gaps 180° apart in line with piston pin centerline.

2) No. 2 compression ring gap 180° from top oil rail gap. No. 1 compression ring gap 180° from No. 2 ring gap. Upper and lower compression ring markings indicate top side of ring.

3) Lightly coat pistons, rings and cylinder walls with engine oil. Install suitable ring compressor on pistons, ensuring ring gap positions do not change.

4) With connecting rod studs covered for cylinder wall protection, install each piston and rod assembly (with notch on piston head toward front of engine) in it's respective bore.

5) Guide connecting rod onto crankshaft journal while tapping piston with suitable tool to seat connecting rod against crankshaft.

6) Install mating rod cap and tighten rod cap nuts. **NOTE** — With pistons installed, cylinder number should be outboard and squirt hole inboard.

FITTING PISTONS

Measure cylinder bore diameter $2\frac{5}{16}$ " below top of cylinder bore. Measure piston at right angles to piston pin at centerline of pin. If clearance is not within specifications, replace piston.

PISTON PINS

Removal — Place piston on suitable support and using tool (J-21872) or equivalent, press pin from piston and rod with arbor press. Note position of pin through gauge window of support. **NOTE** — Never reuse piston pin after it has been installed in and removed from a connecting rod.

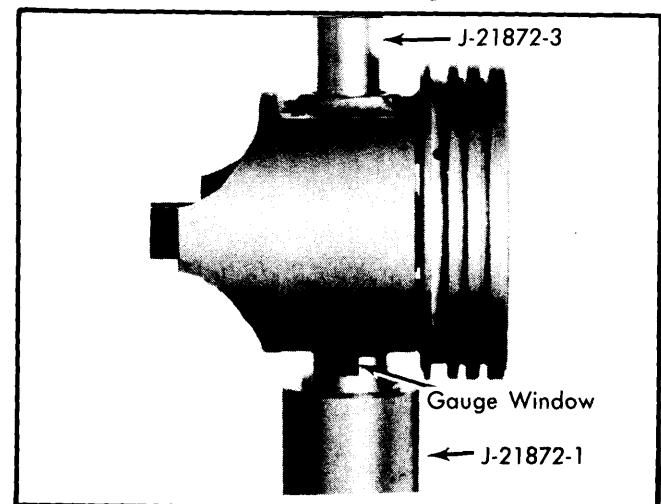

Fig. 3 Piston Pin Removal & Installation

304" & 360" (Cont.)

Installation – 1) Using suitable pilot, driver and support (J-21872), press piston through connecting rod and piston until pin pilot indexes with mark on support.

2) Pin should be centered in rod $\pm \frac{1}{32}$ ". **NOTE** – If little effort is required to install piston pin in connecting rod, or if rod moves along pin, a new connecting rod is required. Check piston for freedom of movement on pin.

CRANKSHAFT & ROD BEARINGS

MAIN & CONNECTING ROD BEARINGS

Connecting Rod Bearings – 1) With oil pan removed, ensure that rod caps are marked for cylinder identification. Remove rod caps. Use Plastigage method to check for proper bearing clearances. If not within specifications, new bearings must be installed.

2) New bearings are available in .001", .002", .010" and .012" undersize. Selective fitting is required on each connecting rod.

3) Although bearings may be interchanged, NEVER use a pair of bearings with more than .001" difference in size on the same journal. **NOTE** – Never use a new bearing with a used bearing.

4) Coat bearing surface with oil, install rod cap and tighten nuts.

Main Bearings – 1) Support crankshaft at counterweight adjacent to main bearing being checked. Ensure that all other bearing caps are tight.

2) Starting with rear main bearing cap and working forward, remove one cap at a time and check bearing clearances. Use Plastigage method.

3) If clearances are not within specifications, bearings are available in .001", .002", .010" and .012" undersize. **NOTE** – Never use a new bearing with a used bearing. Do not use a pair of bearings with more than .001" difference in size on same journal.

4) Remove all upper bearings by inserting suitable tool in oil hole of crankshaft journal. Rotate crankshaft clockwise to roll bearing from engine.

5) Oil new bearing and place firmly against crankshaft journal. Rotate crankshaft so bearing will turn in direction toward it's locating tang. Install bearing cap with lower bearing and tighten bolts.

THRUST BEARING ALIGNMENT

When replacing thrust bearings (located at No. 3 main bearing journal), crankshaft should be moved fore and aft to align thrust faces of bearings.

REAR MAIN BEARING OIL SEAL

Removal – Remove oil pan and rear main bearing cap. Loosen all remaining main bearing bolts. Using a brass drift, tap upper seal until it is protruding enough to permit pulling it out completely. Remove lower seal from bearing cap.

Installation – Reverse removal procedure while noting following: Lips of seal must face toward front of engine. Ensure seal is firmly seated in bearing cap recess. Use suitable sealer.

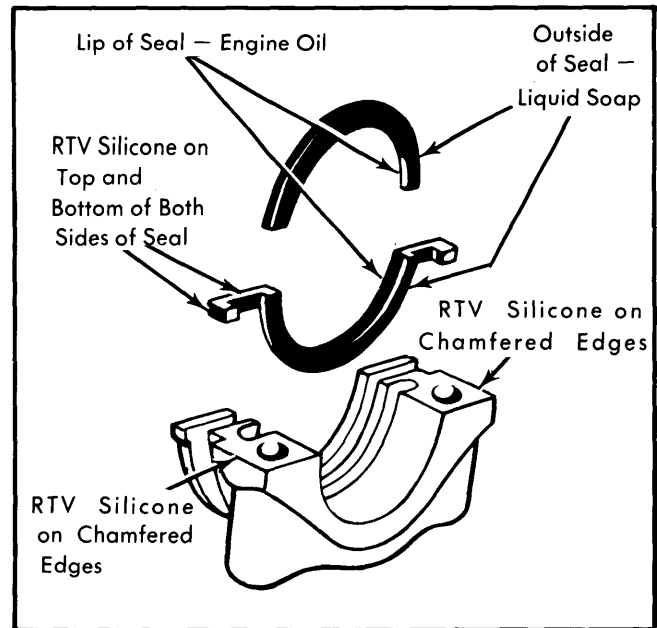

Fig. 4 Rear Main Bearing Oil Seal

CAMSHAFT

ENGINE FRONT COVER

Removal – 1) Drain cooling system and disconnect radiator hoses and bypass hose. Remove drive belts, fan and hub assembly and distributor. Remove fuel pump, drive pulley and vibration damper.

2) Remove A/C compressor and power steering pump. Do not disconnect hoses. Position to one side. Remove alternator and bracket from engine. Remove two front oil pan bolts.

3) Remove bolts securing timing chain cover to block. **NOTE** – Bolts vary in length and must be installed in same location as removed. Pull cover forward until free of locating dowel pins.

Installation – 1) Remove lower locating dowel pin from engine block. Clean all gasket surfaces. Cut both sides of oil pan gasket flush with engine block.

2) Using old gasket as guide, trim new gasket to match amount cut off at oil pan. Apply suitable sealer to both sides of gasket. Install on engine front cover.

3) Install front oil pan seal. Align tongues of new oil pan gasket with seal and cement into place on cover.

4) Apply suitable sealer to cut off edges of original oil pan gaskets. Place cover into position. Install two front oil pan bolts. Tighten bolts slowly and evenly until cover aligns with upper locating dowel.

5) Install lower dowel through cover and drive into matching hole in engine block. Install cover retaining bolts in same location as removed and tighten.

304" & 360" (Cont.)

FRONT COVER OIL SEAL

Removal & Installation — Remove engine front cover and pry out seal from inside of cover. Clean seal bore and apply light coat of suitable sealer to outer surface of new seal. Drive seal into place from inside cover using suitable tool (J-22533). When seal contacts outer flange of cover it is installed correctly. Apply a light film of engine oil to lips of neoprene seal.

TIMING CHAIN

Removal — 1) Remove engine front cover and crankshaft oil slinger. Remove camshaft sprocket retaining bolt and washer. Remove distributor drive gear and fuel pump eccentric.

2) Rotate crankshaft until timing mark on sprocket is aligned with camshaft sprocket timing mark (see Fig. 5). Remove crankshaft sprocket, camshaft sprocket and timing chain as an assembly.

Installation — 1) Assemble timing chain, crankshaft sprocket and camshaft sprocket with timing marks aligned (see Fig. 5). Install assembly to crankshaft and camshaft.

2) Reverse removal procedure to complete assembly. **NOTE** — Fuel pump eccentric must be installed with stamped word "REAR" facing camshaft sprocket.

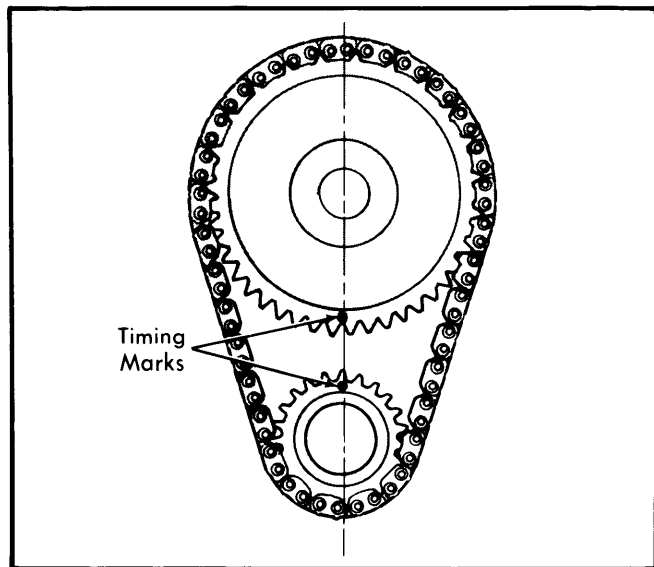

Fig. 5 Timing Chain Sprocket Alignment

CAMSHAFT

Removal — 1) Drain cooling system and remove radiator assembly. Remove A/C condenser and receiver assembly (without disconnecting hoses) and set to one side.

2) Remove rocker arm cover, rocker arm assemblies, push rods and lifters. **NOTE** — Retain rocker arm assemblies, push rods and lifters in order, for reinstallation in original location.

3) Remove engine front cover and timing chain. Remove hood latch support bracket upper retaining screws. Move bracket for access to camshaft.

4) Remove front bumper or grille (as required), and carefully remove camshaft.

Installation — Reverse removal procedure while noting following: Lubricate camshaft with suitable oil supplement and install camshaft carefully to avoid damage to camshaft lobes.

CAMSHAFT BEARINGS

Removal & Installation — With camshaft removed, remove bearings using suitable bearing remover. Bearing bores are step-bored (largest at front, smallest at rear). Install bearings using suitable bearing installer and install camshaft.

CAM LOBE LIFT

1) Remove rocker arm cover, rocker arm and bridged pivot assemblies. Remove spark plugs and proceed as follows:

2) Use suitable clamping or mounting device. Attach dial indicator to cylinder head so indicator probe rests on top of push rod and in a vertical position over push rod.

3) Rotate crankshaft slowly until valve lifter is on heel of cam lobe. Push rod is now at its lowest point. **CAUTION** — If using an auxiliary starter switch, distributor primary lead must be disconnected from negative post of coil.

4) Set dial indicator to zero. Rotate engine until push rod is in fully raised position. If not within specifications, camshaft and lifters should be replaced.

VALVE TIMING

1) Remove spark plugs, rocker arm covers, and rocker arm assemblies from No. 1 cylinder. Rotate crankshaft until No. 6 piston is at TDC on compression stroke and rotate crankshaft counterclockwise 90° from this position. Install a dial indicator on No. 1 intake valve rocker arm push rod end. Set dial indicator to zero.

2) Crank engine slowly in clockwise direction until dial indicator shows a lift of .020". Timing mark on vibration damper should be in line with TDC or zero marking on timing chain cover. If variation of more than 1/2" in either direction exists, remove timing chain cover and inspect timing chain installation.

ENGINE OILING

Crankcase Capacity — 4 quarts. Add 1 quart with filter change.

Oil Filter — Replace every 7500 miles or 7 months, whichever comes first.

Normal Oil Pressure — 13 psi minimum at 600 RPM and 37-75 psi maximum at 1600+ RPM.

Pressure Regulator Valve — Located in pump body. Not adjustable.

304" & 360" (Cont.)

ENGINE OILING SYSTEM

Oil is drawn from oil pan into gallery at lower right side of engine. A passage in timing chain cover channels oil into oil pump. Oil then flows through oil filter equipped with by-pass valve and to gallery extending to left front of engine. Oil passes directly to right main gallery and intersects with short passage leading to left main gallery. Engine components are then lubricated as follows:

Crankshaft & Camshaft Bearings – Passages extend down from right main oil gallery to each camshaft bearing and to each upper main bearing. Passages in crankshaft allow oil flow from main bearing journal to adjacent connecting rod journal. A squirt hole in connecting rod bearing cap distributes oil on cylinder walls, pistons and piston pins.

Hydraulic Valve Lifters – Lubricated directly from main oil galleries.

Rocker Arms & Push Rods – Oil is delivered from hydraulic lifters and passes through hollow push rods to rocker arms. Rocker arms direct oil onto valve train and oil returns to pan through channels in cylinder head.

Timing Chain & Sprockets – Oil is received from front camshaft bearing. Oil is thrown off sprockets to lubricate distributor gear and fuel pump eccentric. Oil returns to pan through cavity under front main bearing.

OIL PUMP

Oil pump is driven by distributor drive shaft. Removal of pump will not affect ignition timing as distributor gear remains meshed with camshaft gear. With pump cover and gasket removed, gears should project .004-.008" above pump body for proper clearance. **NOTE** – Gears must be up as far as possible into pump body. A clearance of .0005-.0025" should exist between gears and wall of gear cavity. Fill pump with petroleum jelly prior to installation of cover. DO NOT use grease.

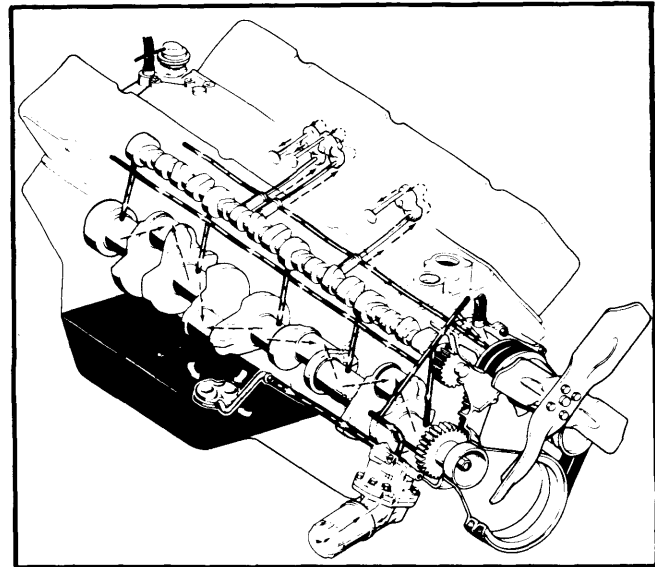

Fig. 6 Engine Oiling System

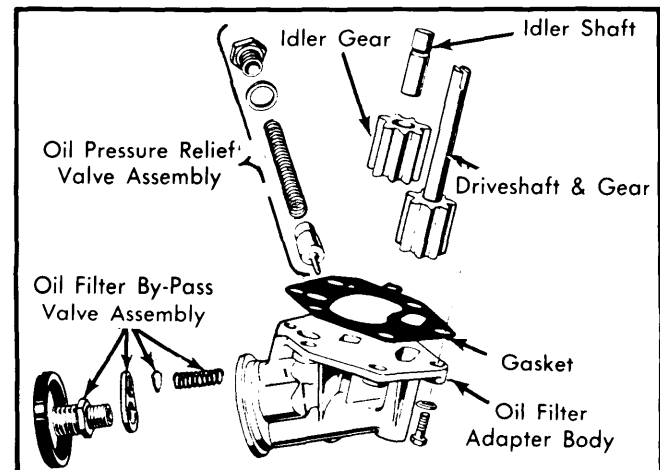

Fig. 7 Oil Pump Assembly

ENGINE SPECIFICATIONS

GENERAL SPECIFICATIONS						
Engine	Net HP At RPM	Torque (Ft. Lbs. at RPM)	Compr. Ratio	Bore	Stroke	Displ. Cu. Ins.
304" 2-Bbl.	121@3450 ^① 126@3600 ^②	219@2000	8.4-1	3.75"	3.44"	304
360" 2-Bbl.	129@3700 ^① 138@3600 ^②	245@1600 ^① 248@1600 ^②	8.25-1	4.08"	3.44"	360

① – Federal (49 States) ② – California

VALVES							
Engine & Valve	Head Diam.	Face Angle	Seat Angle	Seat Width	Stem Diameter	Stem Clearance	Valve Lift
304" Int.	1.787"	29°	30°	.040-.060"	.3715-.3725"	.001-.003"
Exh.	1.406"	44°	44.5°	.040-.060"	.3715-.3725"	.001-.003"
360" Int.	2.025"	29°	30°	.040-.060"	.3715-.3725"	.001-.003"
Exh.	1.680"	44°	44.5°	.040-.060"	.3715-.3725"	.001-.003"

American Motors V8 Engines

304" & 360" (Cont.)

ENGINE SPECIFICATIONS (Cont.)

VALVE SPRINGS			
Engine	Free Length	PRESSURE (LBS.)	
		Valve Closed	Valve Open
304" & 360"	2.20"	80-88@1 ¹³ / ₁₆ "	210-216@1 ²³ / ₆₄ "

PISTONS, PINS, RINGS						
Engine	PISTONS	PINS		Rings	RINGS	
	Clearance	Piston Fit	Rod Fit		End Gap	Side Clearance
304"	.001-.018"	.0003-.0005"	Press Fit	1	.010-.020"	.0015-.0035"
				2	.010-.020"	.0015-.0030"
				3	.010-.025"	.0011-.0080"
360"	.0012-.0020"	.0003-.0005"	Press Fit	1	.010-.020"	.0015-.0030"
				2	.010-.020"	.0015-.0035"
				3	.015-.045"	.000-.007"

CRANKSHAFT MAIN & CONNECTING ROD BEARINGS							
Engine	MAIN BEARINGS				CONNECTING ROD BEARINGS		
	Journal Diam.	Clearance	Thrust Bearing	Crankshaft End Play	Journal Diam.	Clearance	① Side Play
304" & 360"	2.7482"②	.001-.003"③	No. 3	.003-.008"	2.0945"	.001-.003"	.006-.018"

- ① — Total two rods
- ② — Rear Main is 2.7472"
- ③ — Rear Main is .002-.004"

VALVE TIMING				
Engine	INTAKE		EXHAUST	
	Open (BTDC)	Close (ALDC)	Open (BLDC)	Close (ATDC)
304" & 360"	15°	69°	57°	27°

CAMSHAFT			
Engine	Journal Diam.	Clearance①	Lobe Lift
304" & 360"	No. 1 2.120"②	.001-.003"	.266"

- ① — Endplay is .000" with engine running.
- ② — Each succeeding journal .030" smaller.

TIGHTENING SPECIFICATIONS	
Application	Ft. Lbs.
Cylinder Head	110
Intake Manifold	43
Exhaust Manifold	25
Oil Pan 1/4"	7
5/16"	11
Main Bearing Caps	100
Connecting Rod	33
Flywheel-to-Crankshaft	105
Vibration Damper	90
Camshaft Sprocket	30
Rocker Arm Cap Screws	19
Engine Front Cover	25
Thermostat Housing	13
Water Pump	4
Oil Pump Cover	INCH 55
Air Injection Tube-to-Manifold	38