

## FORD MOTOR CO. PROPELLER SHAFT ALIGNMENT

Ford, Mercury & Lincoln Continental  
 Continental Mark IV & Thunderbird  
 Torino, Montego, Elite & Cougar  
 Ranchero

### Pinion Angle Degree & Controlled Height

### DESCRIPTION

Pinion nose and propeller shaft angle are controlled by either a single rear suspension upper control arm on Ford, Mercury and Lincoln Continental, or by two lower control arms on all other models. Whenever control arm(s) are removed, pinion nose angle must be adjusted.

### CHECKING & ADJUSTMENT

**Checking** - 1) Measure distance from top of axle housing to a point on frame rail adjacent to axle bumper rear bolt. Average measurements taken. Find rear suspension height as recorded in table. Project upward to curved line. Project horizontally to find pinion angle degrees. Position "V" magnet of Tool T68P4602-A on drive shaft away from welds and balance weights.

2) From left side of vehicle, position tool on "V" magnet with adjusting screw to left. Adjust dial on tool until left-hand of bubble is on zero line. Position tool on "U" joint bearing cap with tool in same relative position as it was on "V" magnet. Read position of bubble and compare to degree specifications recorded with those in table. If adjustment is necessary, adjust to within plus or minus 30 minutes.

### Specifications

Vehicle	Degree	Controlled Height
Torino, Montego, Elite, Cougar 2 Dr		
8" axle	1°42' ± 45'	4.82"
9" axle	2°33' ± 45'	4.82"
Torino, Montego 4 Dr		
8" axle	1°40' ± 45'	4.82"
9" axle	2°28' ± 45'	4.82"
Torino, Montego Station Wagon & Ranchero		
8" axle	0°37' ± 45'	4.82"
9" axle	1°7' ± 45'	4.82"
Thunderbird	2°44'	4.82"
Mark IV	2°47'	4.82"
Lincoln Continental	8°4' ± 50'	5.70"
Ford, Mercury	2°48' ± 50'	5.70"

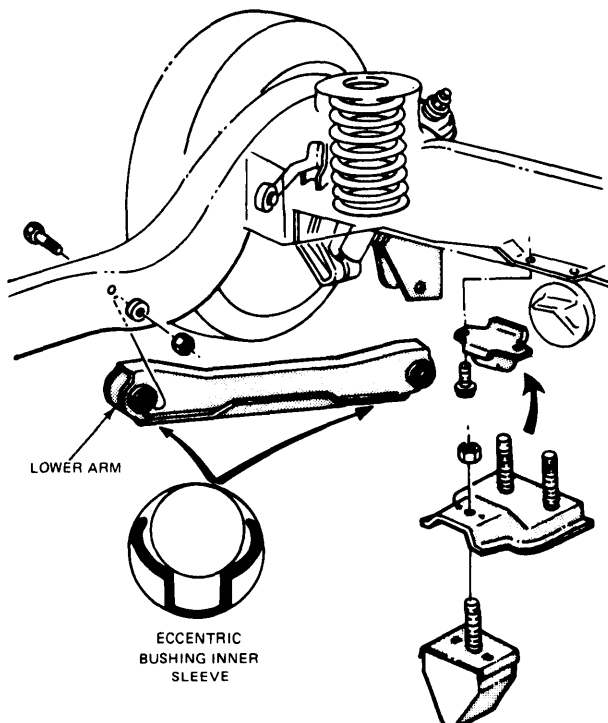

2F5009

**PINION ANGLE ADJUSTMENT  
 TORINO, MONTEGO, T-BIRD, & MARK IV**

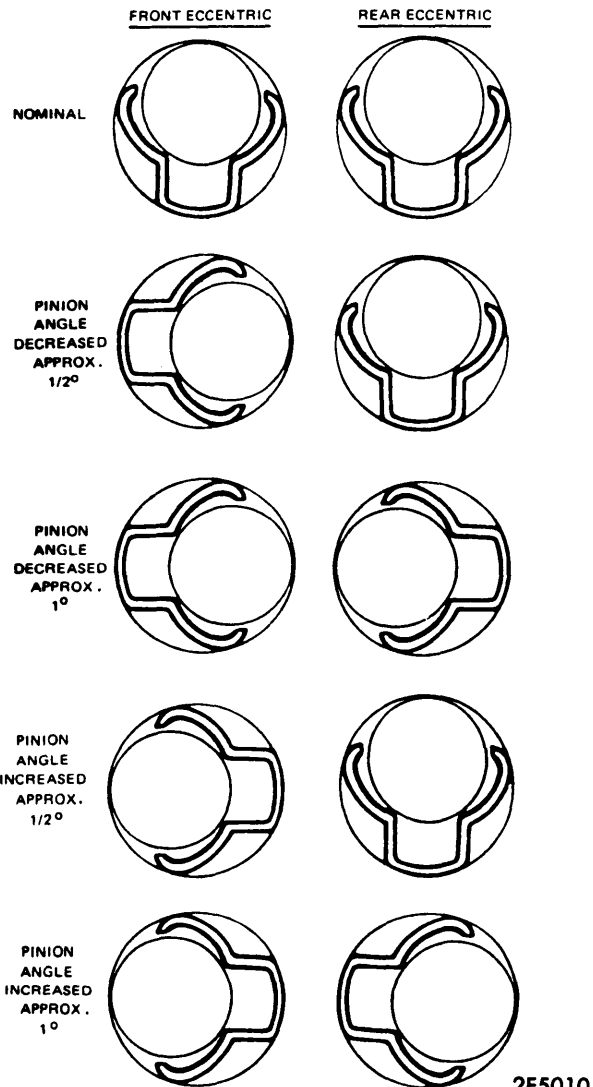

2F5010

**ECCENTRIC BUSHING INNER SLEEVE POSITIONS**

# Propeller Shaft Alignment

## FORD MOTOR CO. PROPELLER SHAFT ALIGNMENT (Cont.)

**Adjustment (Single Upper Arm)** — If angle is not within specifications, upper arm-to-axle housing bolt and two eccentric washers form an adjusting cam mechanism which will tilt the axle housing to required angle. At time of adjustment, replace pivot bolt, nut and lock washer and leave the nut loose. If angle is less than specification, rotate adjusting cam forward and check angle. If angle is more than specified, rotate adjusting cam rearward and check the angle. When axle housing is adjusted to specifications, tighten pivot bolt and nut.

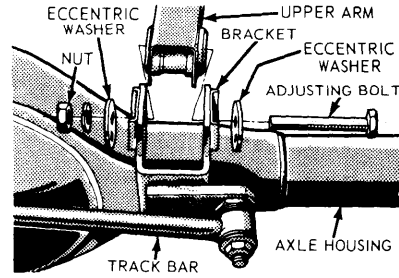

**PINION ANGLE ADJUSTMENT  
FORD, MERCURY & LINCOLN CONTINENTAL**

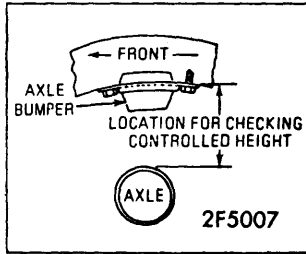

**CONTROL HEIGHT**

**Adjustment (Double Lower Arm)** — If angle is not within specifications, raise and support vehicle and use a jack under the pinion housing to unload the control arm bushings. At time of adjustment on Torino, Montego, Elite and Cougar, install a new service arm kit, which includes arms and adjusting cams; or on Thunderbird and Mark IV, install new nonserrated inner sleeve with adjusting cam. Use tool T72P-5538-A to rotate eccentric bushing clockwise or counterclockwise to raise or lower pinion nose angle to specification. If further adjustment is required, use same procedure at rear end of arms. When adjustments have been completed install new nuts and bolts.

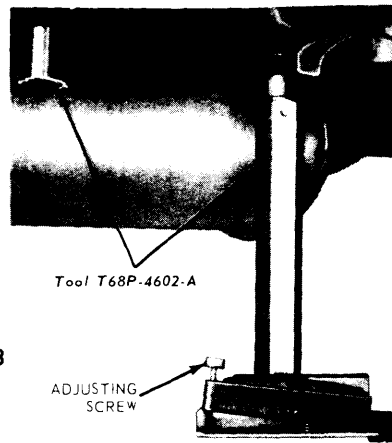
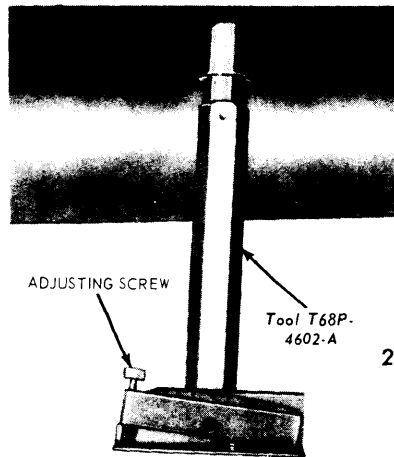

2F5008

**MEASURING DIFFERENTIAL NOSE ANGLE**