

# Front Wheel Final Drive

## G.M. FRONT WHEEL FINAL DRIVE

Cadillac Eldorado  
Oldsmobile Toronado

### DESCRIPTION

Final drive assembly is mounted and splined directly to automatic transmission, and consists of a pinion drive gear, ring gear, and differential case assembly. A twin gasket assembly is used between final drive housing and cover to provide a controlled vent for excess lubricant. Torque from final drive unit is transmitted to output shafts which connect to drive axles. Output shafts are splined to the side gears in final drive assembly. Drive axles are a flexible assembly consisting of axle shafts and inner and outer constant velocity joints. Two axle ratios are available: 2.73-1 with axle ratio code "S" is standard equipment on all models; 3.07-1 with axle ratio code "T" is optional on Eldorado only.

### REMOVAL & INSTALLATION

#### DRIVE AXLES

**Right Axle Removal** - 1) Disconnect negative battery terminal, then hoist vehicle under lower control arms. On Toronado models, remove oil filter element. On Eldorado models, install a short length of rubber hose on lower torsion bar connector to prevent damage to drive axle seals. Loosen, DO NOT remove lower shock absorber mounting nut, then pry shock absorber along lower mounting stud until it reaches nut.

2) Remove drive axle-to-output shaft attaching bolts, then push drive axle outward and rearward to disengage it from output shaft. Remove output shaft support bolts from engine and final drive, then remove output shaft. Remove drive axle cotter pin, then loosen, do not remove, spindle nut. Using a block of wood and a hammer, strike end of drive axle to unseat axle at hub, then remove drive axle.

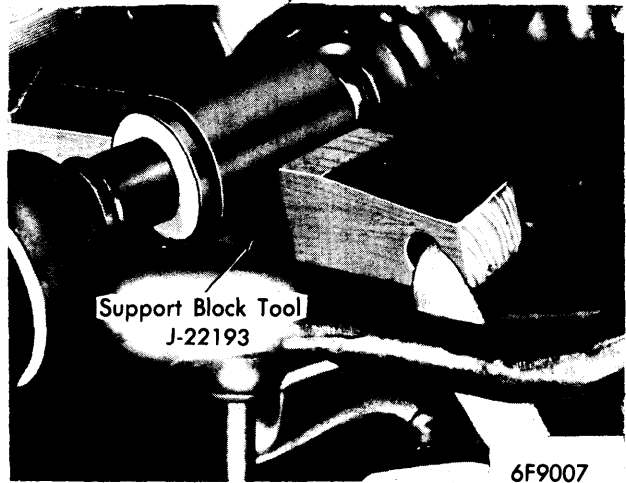

AXLE SUPPORT BLOCK

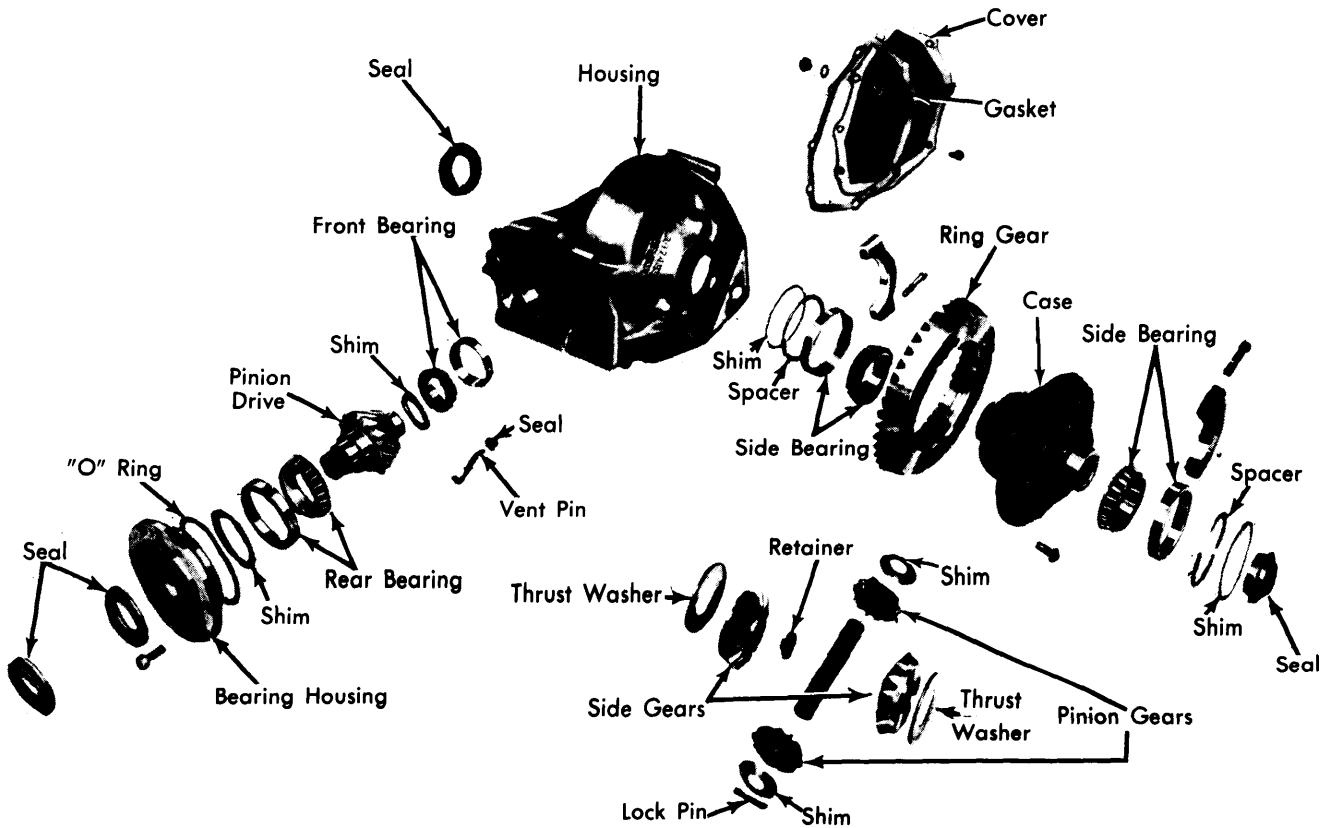

9F4509

FINAL DRIVE ASSEMBLY

## G.M. FRONT WHEEL FINAL DRIVE (Cont.)

**Installation** — To install, reverse removal procedure and note following: When installing output shaft, coat output shaft seal with Special Seal Lubricant No. 1050169, or equivalent.

**Left Axle Removal** — 1) Raise vehicle under lower control arms, then remove wheel and tire. Remove drive axle cotter pin, retainer, and washer, nut. On Toronado models, remove tie rod end cotter pin and nut, then using suitable tool, remove tie rod end from steering knuckle. On all models, remove drive axle-to-output shaft screws and discard. On Eldorado models, loosen shock absorber upper mounting bolt. On all models, remove upper ball joint stud cotter pin and nut, then remove brake hose clip from ball joint stud. Using a hammer and a brass drift, drive on knuckle until ball joint stud is free.

2) On Toronado models, remove lower ball joint from steering knuckle using suitable puller. Remove knuckle, then guide drive axle assembly out of vehicle. On Eldorado models, remove brake hose bracket from frame, then tip disc and knuckle assembly out at upper end to extent of brake hose. **NOTE** — Wire assembly to upper control arm to prevent damage to brake hose. Rotate inner end of drive axle toward front of vehicle, then guide axle out of knuckle and remove from vehicle.

**Installation** — To install, reverse removal procedure and note following: Upper ball joint stud cotter pin must be crimped toward upper control arm to prevent interference with outer C.V. joint seal.

### OUTPUT SHAFT

**Right Output Shaft Removal** — Disconnect drive axle. Remove drive axle support from engine on Toronado models, or from engine and final drive assembly on Eldorado models, then remove output shaft from vehicle. If seal is to be removed, use a suitable tool and remove from housing. If output shaft bearing is to be replaced, use an arbor press and suitable support.

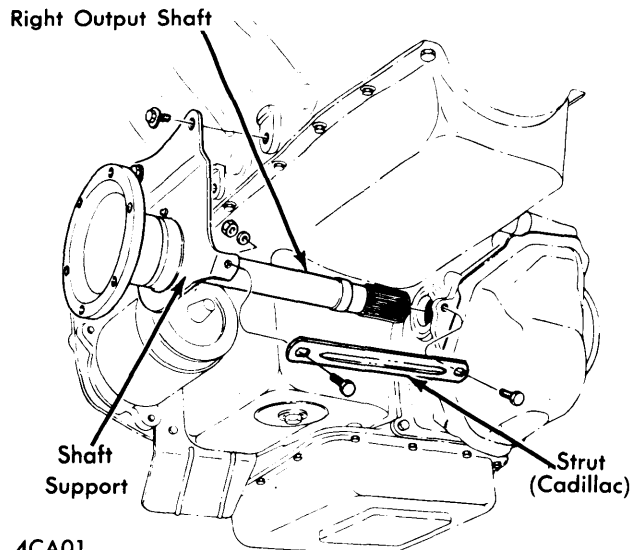

4CA01

### RIGHT OUTPUT SHAFT ATTACHMENT (TYPICAL)

**Installation** — To install, reverse removal procedure and note following: Do not allow shaft to hang. If bearing was removed, pack area between bearing and retainer with wheel bearing grease. If seal was removed, lubricate with Special Seal Lubricant No. 1050169 or equivalent. Assemble support bolts loosely, locate center position of shaft, then support shaft in this position while tightening bolts.

**Left Output Shaft Removal** — Remove left drive axle, remove output shaft retaining bolt, then pull output shaft from housing. If seal is to be replaced, remove using hammer and suitable puller.

**Installation** — To install, reverse removal procedure and note following: Install seal with vent hole toward top of housing. Apply suitable lubricant to seal before installing output shaft.

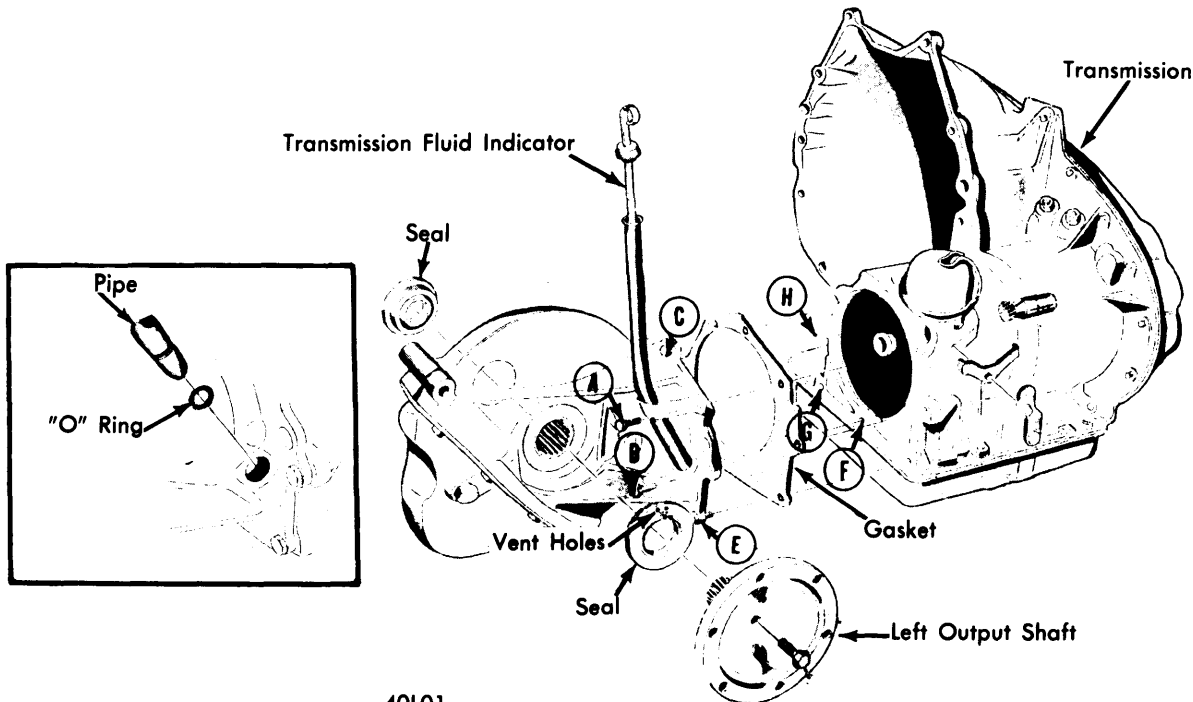

40L01

### FINAL DRIVE ATTACHMENT

## G.M. FRONT WHEEL FINAL DRIVE (Cont.)

## FINAL DRIVE ASSEMBLY

**Removal** — 1) Disconnect negative battery terminal, then remove transmission filler tube. Remove bolts "A", "B", and "C", securing upper part of final drive housing to transmission housing. Hoist vehicle, then support at front frame side rails. On Toronado models, remove oil filter element. On Eldorado models, remove screw securing cooler lines and clip to support bracket.

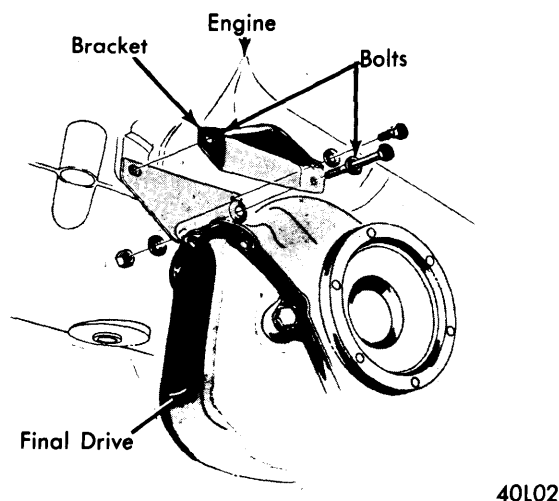

FINAL DRIVE-TO-ENGINE ATTACHMENT

2) Disconnect drive axles from output shafts, then remove right output shaft. Remove bolt securing final drive support brace to engine mount bracket. Remove final drive cover and allow lubricant to drain, then position suitable lifting device and adapter on final drive assembly (see illustration). Remove bolts "E", "F", "G" and "H", then disengage final drive from transmission. Lower final drive assembly out of vehicle.

**Installation** — 1) Install left output shaft in final drive assembly (if removed), then place assembly on suitable lifting device. Apply a thin film of transmission fluid to new final drive-to-transmission gasket, then place gasket on transmission. Move final drive into position on transmission. **NOTE** — It may be necessary to rotate left output shaft to align final drive splines with transmission splines.

2) Install bolts "E", "F", "G" and "H" and tighten, then install bolt securing final drive support brace to engine mount bracket. Install final drive cover with new gasket, then complete installation by reversing removal procedures. After vehicle is lowered, install bolts "A", "B", "C", and tighten.

## OVERHAUL

## CONSTANT VELOCITY JOINT

**NOTE** — On Oldsmobile Toronado inner and outer Constant Velocity Joints are serviced only to replace seals, must be replaced if damaged. On Eldorado, only outer joints must be replaced if damaged.

**Outer Joint (Disassembly)** — Clamp mid-part of axle shaft in a vise, then remove inner and outer seal clamps and slide seal down shaft. Use a suitable tool and spread retaining ring until joint can be removed from axle spline. Remove retaining ring and slide seal from axle shaft. Hold joint with one hand and tilt cage and inner race so one ball can be removed, then continue until all balls are removed. Turn cage 90° and with large slot in cage aligned with land in inner race lift out. With cage and inner race assembly, turn inner race 90°, in line with large hole in cage, lift land on inner race up through large hole in cage and turn up and out to separate parts.

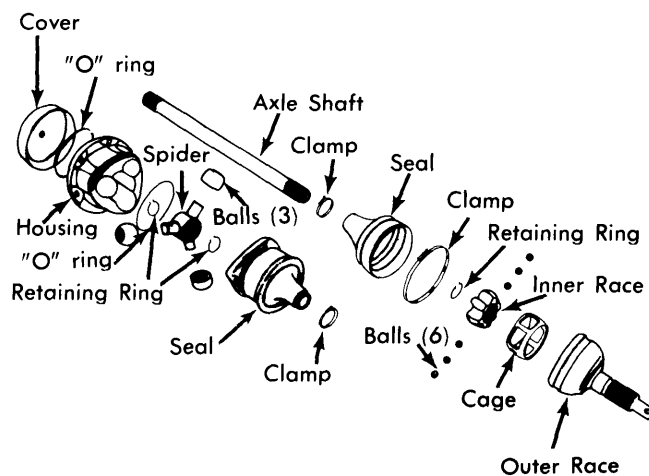

DRIVE AXLE ASSEMBLY

3F4506

**Inspection** — Wash all metal parts in solvent and blow dry with air. Inspect outer race for scoring or wear in ball splines. Inspect shaft splines and threads for damage. Inspect balls for nicks, cracks, breaks or scores. Inspect cage for cracks or breaks. Inspect inner race for wear, scores, or breaks. Inspect retaining ring. **NOTE** — If any of the above defects are found, the complete joint assembly must be replaced as a unit.

**Reassembly** — Insert land of inner race into large hole in cage and pivot to install in cage. Align inner race and cage with lands of outer race, then pivot assembly into outer race. Insert balls into outer race one at a time, tilting inner race and cage so that each ball can be installed. Pack joint with suitable lubricant, (Olds No. 7805942 or equivalent), then use same lubricant to pack inside of seal, until folds of seal are full. Place small service clamp on axle shaft, install seal on axle shaft, then install retaining ring into inner race and insert axle shaft into splines of outer joint until retaining ring secures shaft. Position seal in slot of outer race and install large seal clamp. Install small clamp and secure in place.

**Inner Joint (Disassembly)** — 1) With axle assembly on a bench, pry up staked areas of seal retainer and drive seal off housing with a hammer and chisel. Stand axle assembly and joint housing vertically on bench, then carefully withdraw axle from housing. **NOTE** — Place a rubber band over ends of spider to retain balls and needle bearings. Clamp mid-portion of axle shaft in a vise, taking care not to damage axle. Remove snap ring from end of axle shaft, then slide spider assembly from shaft.

## G.M. FRONT WHEEL FINAL DRIVE (Cont.)

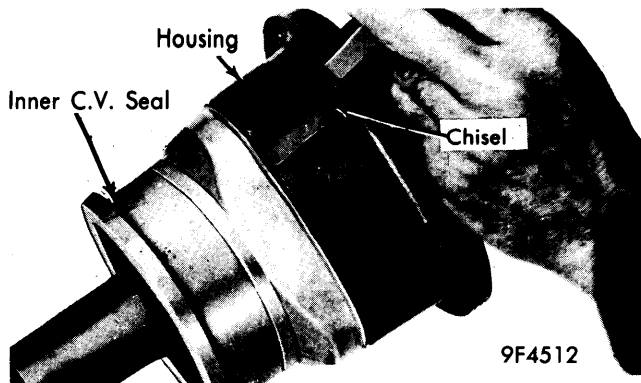

REMOVING INNER C.V. JOINT SEAL

2) Remove inner snap ring from axle shaft, then remove seal clamp and slide boot seal off shaft. Remove balls from spider, taking care not to lose any of the 53 needle bearings in each ball. If necessary to remove cover, place a wood block approximately 2" x 2" x 8" in housing, then drive block with a hammer to remove cover from housing. Remove and discard "O" ring.

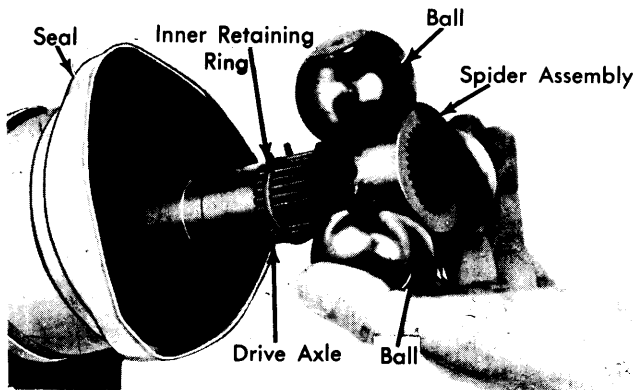

INSTALLING SPIDER ASSEMBLY

**Reassembly** — Reverse disassembly procedures, lubricating all shaft and bearing surfaces with suitable lubricant. **NOTE** — Mating area of seal adapter and joint housing must be free of lubricant to insure proper sealing.

### FINAL DRIVE DISASSEMBLY

**NOTE** — Cadillac does not recommend that final drive be serviced, except for replacement of seals. If damaged, unit must be replaced.

1) Mount final drive in a suitable holding fixture. Using a dial indicator mounted on housing with pinion pointed downward, check and record ring gear to pinion backlash at four points around ring gear. If lash varies more than .002", check for burrs, uneven bolting conditions, or distorted case and make corrections as necessary.

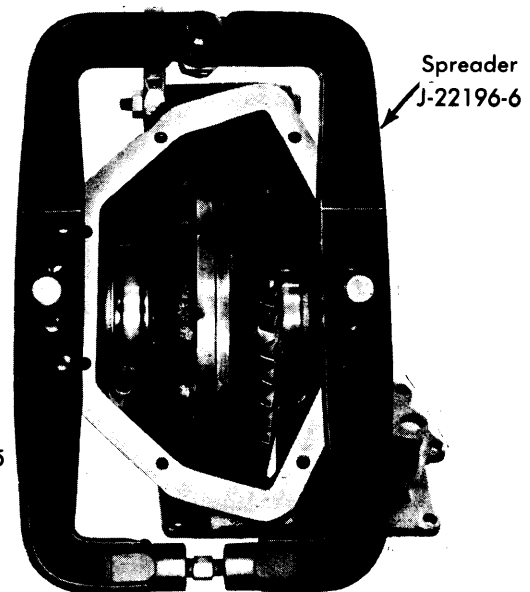

SPREADING CARRIER HOUSING

2) Remove side bearing caps and install suitable spreading tool (J-22196) on final drive, indexing guides on spreader with holes on carrier, then expand spreader until spacer and shims can be removed from between right side bearing and housing. Retain spacers and shims for reassembly. **CAUTION** — Spread housing only enough to relieve tension on spacer and shims. Remove spreader from housing.

3) Remove other spacers and shims, then slide case assembly to left away from pinion gear and remove from housing. With pinion pointed upward, check and record torque required to rotate pinion. Remove bearing housing bolts, then remove drive pinion and housing using a slide hammer and suitable adapter. Remove pinion from housing, then remove "O" ring from housing.

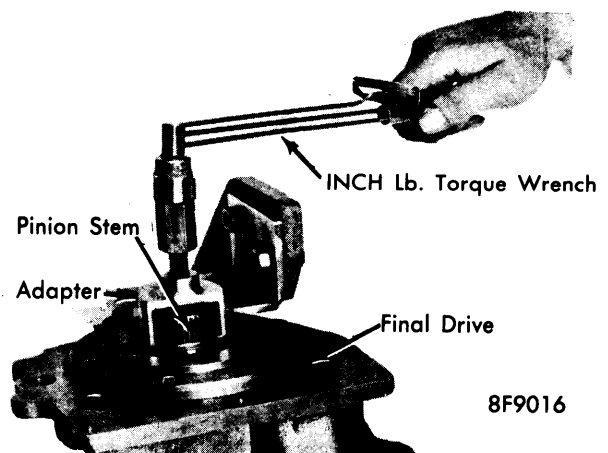

CHECKING PRELOAD

## G.M. FRONT WHEEL FINAL DRIVE (Cont.)

4) Remove seal and vent pin from housing. Using a slide hammer and suitable adapters, remove pinion front bearing outer race, then remove output shaft oil seals using suitable seal puller. Remove oil seals from pinion bearing housing using suitable driver, then, if necessary, remove rear pinion bearing outer race using suitable tools (BT-6702-3&4, BT-6708-1, BT-6708-2).

### PINION DISASSEMBLY

Remove pinion front bearing using suitable puller or press, then remove rear bearing using suitable puller (J-9746).

### DIFFERENTIAL CASE DISASSEMBLY

If side bearings are to be removed, remove with a suitable puller or press. Mark ring gear and case for reassembly reference, then remove all but two ring gear-to-case bolts, leaving two bolts loosely installed 180° apart. Position case on bench with ring gear down, tap lightly to separate, then remove remaining bolts and ring gear. Drive out pinion shaft lock pin, remove pinion shaft, then remove pinion gears one at a time through access hole in case, keeping corresponding shims and pinion gears together. Remove side gears and thrust washers, keeping corresponding parts together. *NOTE* — *Left side gear has threaded retainer that retains left output shaft. If necessary, retainer may be removed with a brass drift and hammer.*

### PINION DEPTH SETTING

1) Install pinion front outer race in housing and drive it into place until it bottoms, using a suitable tool, then install front bearing into race. *NOTE* — *Lubricate bearing with final drive lubricant before installation.*

2) Place Tool J-21777-10 on front bearing, then install Tool J-21579 on final drive housing and retain with two bolts. Thread Tool J-21777-13 into J-21579 until tip of screw engages Tool J-21777-10 and tighten screw to 20 inch pounds to preload bearing.

3) Remove dial indicator post from Tool J-21777-1 and install discs J-21777-22. Install the assembly in side bearing bores. Install bearing caps. Position dial indicator on mounting post of gauge shaft with contact rod off gauging area. Set dial indicator to zero, depress indicator until needle rotates ¾ turn clockwise, tighten indicator in this position, reset to zero.

4) Place gauge shaft assembly in carrier so dial indicator contact rod is in line with, BUT NOT ON gauging area and discs fully seated. Rotate gauge assembly so that indicator rod sweeps gauging area, note greatest deflection. At this point, pinion depth may be read directly from dial.

5) If a service gear set, or a production gear set with no marking is being used, shim thickness should be equal to dial indicator reading. If ring gear is marked "+", increase shim thickness indicated on dial indicator by number painted on ring gear. If ring gear is marked "-", decrease thickness indicated on dial indicator by number painted on ring gear. Remove pinion depth checking tools and front bearing from carrier.

### PINION REASSEMBLY

Press rear pinion bearing on shaft using an arbor press and suitable adapters. Place selected shim pack on drive pinion and press front pinion bearing on shaft with arbor press. Lubricate bearings with final drive lubricant. *NOTE* — *Shims are available from .040" to .070" in increments of .002".*

### FINAL DRIVE REASSEMBLY

**Pinion Bearing Preload Adjustment** — Position pinion bearing race on pinion bearing, then install tool J-22587 or equivalent. Check clearance between race and tool using a feeler gauge. Shims are available from .036-.070" in increments of .002". Add shims to obtain a preload of 2-5 INCH lbs. for used bearings, or 2-15 INCH lbs. for new bearings, checked with a torque wrench. Record shim thickness used. Using a dial indicator and tool J-22587-2, determine difference between inner and outer flange of bearing housing. Add housing difference to shim thickness, subtract .027" to compensate for tool used and variance caused by installation. Final result is actual pinion bearing preload shim required.

**Pinion Shaft Assembly** — Position selected shim in bearing housing, then install rear bearing outer race. Install bearing housing oil seals, "O" ring seal, vent pin and seal on housing face. Install bearing housing to final drive housing, install bolts and tighten. Recheck pinion bearing preload.

**Differential Case Assembly** — Install side bearings on case. Place side gear thrust washers over hubs, then install side gears. If original parts are used, install in original position. *NOTE* — *Side gear with threaded retainer must be installed on left side of case. Place pinion gears in case so that holes in gears line up with holes in case. When in line, rotate pinions just enough to install shims. Install pinion shaft and lock pin.*

**Ring Gear Assembly** — Install positioning studs in three ring gear bolt holes equally spaced around case. Install case holding tool, then place assembly in vise. Install NEW ring gear attaching bolts in remaining holes. Remove studs, install remaining bolts, then tighten in progressive stages.

**Side Bearing Preload Adjustment** — Place case and side bearing assemblies in position in housing. Install original spacers (.140±.005") on left and right side. If preload was correct at time of disassembly, original shims may be used. Shims are available in increments of .002" from .038-.074". Install spreader (J-22196) on housing and spread housing just enough to install shims. Release tension on spreader tool, in-

## G.M. FRONT WHEEL FINAL DRIVE (Cont.)

stall the side bearing caps and tighten, then check preload using an INCH lb. torque wrench. Preload should be 10-15 INCH lbs. for new bearings, or 5-7 INCH lbs. for used bearings, over pinion bearing preload. If adjustment is necessary, spread housing to increase or decrease shim thickness. Preload reading must be taken with spreader tension released. **NOTE** — By adding or subtracting same amount of shims from both sides, ring gear to pinion backlash will not change.

**Backlash Adjustment** — Rotate differential case a few times to seat bearings, then mount a dial indicator to bear against tooth face of ring gear. Check backlash at four points around ring gear (backlash must not vary more than .002" around ring gear). Backlash at point of minimum should be .005"-.009" for all new gears. If original gears were installed, backlash must be set to the same reading obtained at disassembly providing reading was within specification. To change backlash, increase thickness of one differential shim and decrease thickness of the other (this will maintain side bearing preload). For each .001" change in backlash desired, transfer .002" in shim thickness. When backlash is properly adjusted, remove spreader tool and install bearing caps.

Tighten to specification. Install new output shaft seals, making sure vent hole in left seal is towards top of housing. Install cover and new gasket. **NOTE** — If final drive was removed without the transmission, do not install gasket, cover, or lubricant at this time.

### TIGHTENING SPECIFICATIONS

Application	Ft. Lbs.
Final Drive Cover Bolts.....	25
Side Bearing Cap Bolts.....	65
Bearing Housing Bolts.....	35
Ring Gear Bolts.....	85
Drive Axle to Output Shaft.....	65
Final Drive Support Bracket to Engine.....	50
Final Drive to Support Bolt.....	105
RH Output Shaft Support to Engine.....	50
LH Output Shaft Retainer.....	40
Final Drive to Transmission.....	25