

Positive Traction Differentials

G.M. LIMITED SLIP DIFFERENTIAL (CLUTCH PACK TYPE)

Buick
Cadillac Seville
Chevrolet
Oldsmobile
Pontiac

NOTE — Some models use Borg-Warner differential. See G.M. Limited Slip Differential (Cone Brake Type) in this section.

DESCRIPTION

Two pinion, limited slip, one piece case, uses one clutch pack behind each side gear to limit differential action. All units include spring assemblies of various designs to preload clutch packs. See illustrations.

NOTE — The units are identical in design to conventional differentials except for the internal case design. For procedures involving ring gear, side bearings, and axle shafts, see appropriate rear axle data for each car model.

OVERHAUL

DISASSEMBLY

G.M. Built Unit With "S" Shaped Preload Spring — Remove ring gear, and side bearings. Remove pinion shaft. Using a wide blunt tool such as a drift or wood block, drive preload spring from case. Place axle shaft in vise, and slide case onto shaft, then turn case to remove both pinions and thrust washers. *NOTE — Pinion shaft may be partially installed to aid in rotating case.* Remove case from axle shaft and remove both side gears, clutch packs, and shims; mark them for installation in same positions.

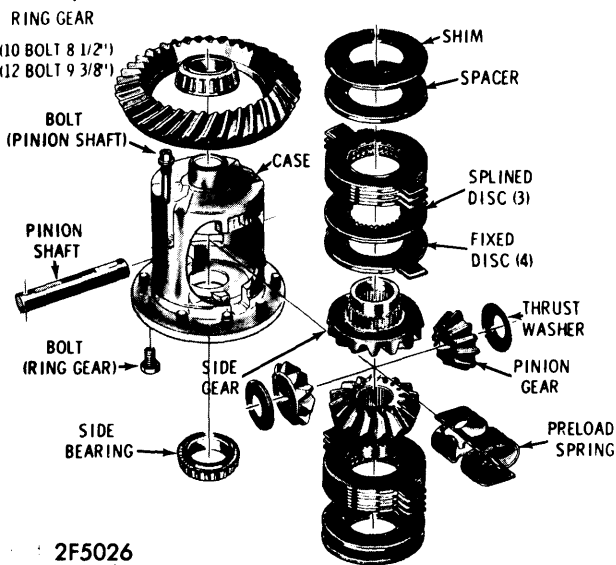

G.M. BUILT POSITRACTION UNIT

Eaton Built Unit With Coil Type Preload Spring —

1) Remove ring gear and side bearings. On all models except Corvette, remove preload spring and retainer through hole in case. Drive spring retainer from case enough to allow insertion of 1/4" bolts in each of two front springs. Secure each bolt with a nut. On Corvette only, it is necessary to raise spring retainers slightly to clear shoulder on side gears. Install suitable tool (J-22311) to clutch pack so that slotted ends are equally engaged at front and rear of spring retainer.

2) After installing bolts, continue to drive spring retainer from case until enough of the retainer is exposed to permit installation of bar stock and a "C" clamp. Center the bar stock over axle shaft hole in spring retainer, then compress "C" clamp sufficiently to permit withdrawal of spring pack. Position pack in vise and remove bolts. Alternately relieve "C" clamp pressure and vise pressure until spring tension is relieved.

3) Pinion gears can be removed by rotating them. Rotate case clockwise to remove first gear, then rotate case counterclockwise to remove second gear. To remove second gear, it may be necessary to assist pinion gear off its seat by prying on gear through observation hole in case. Mark pinions and side gears for reassembly in original position.

4) Remove side gear, clutch pack, shims and guides from case. Tap assembly from case using a brass drift. Repeat removal on opposite gear. Separate clutch pack assembly from side gear. Retain clutch pack assembly with original side gear.

INSPECTION & REASSEMBLY

G.M. Built Unit With "S" Shaped Preload Spring —

1) Check clutch plates and discs for wear and signs of overheating. Check condition of preload springs and gear teeth for signs of wear. Replace parts as required and clean all parts. Lubricate clutch discs and plates with positraction lubricant. Alternately position clutch plates and discs on a side gear, beginning and ending with a clutch plate. Position side gear, clutch pack, and original shim into case. Place case over axle shaft supported in a vise. Insert screwdriver between pinion shaft and face of a side gear. Force screwdriver in until clutch pack is compressed.

2) Check backlash between side gear and pinion gears. If backlash does not fall into the range of .005-.008" adjust the shim dimension as required. Increasing shim thickness will decrease backlash. Remove pinion shaft, pinion gears, side gear, clutch pack and shim from case. Install opposite gear, clutch pack, and original shim into case. Place both pinion gears and thrust washers into position, and install pinion shaft. Now check backlash for this side.

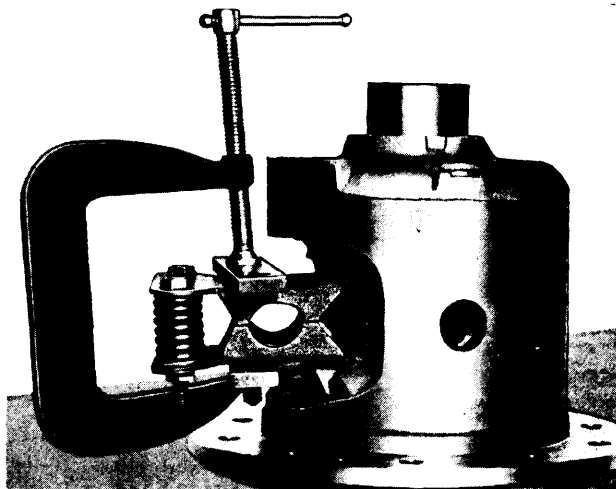

REMOVING PRELOAD SPRING PACK

G.M. LIMITED SLIP DIFFERENTIAL (CLUTCH PACK TYPE) (Cont.)

3) When proper backlash has been achieved, install shims, clutch packs, and side gears into case. Mount case onto axle shaft. Place both pinions and thrust washers into place, 180° apart, and carefully roll in by turning case on shaft. **NOTE** — A large "C" clamp may be used to apply slight compression against pinion gears to aid in rolling in. Tap preload spring into place with a hammer. Install pinion shaft and lock screw. Install side bearings and ring gear.

3) Install dial indicator in case so that contact button rests against pinion gear. Compress clutch pack using a screwdriver. Move pinion gear to obtain tooth clearance. Tooth clearance should be .001-.008". If required change shims to obtain proper tooth clearance. Remove side gear assembly and repeat tooth clearance procedure for opposite side.

Eaton Built Unit With Coil Type Preload Spring —

1) Check clutch plates and discs for wear or signs of overheating. Clutch plates and discs are not serviced separately. If replacement required, clutch pack must be replaced as an assembly. Check preload springs for distortion or defects and replace if weak. Lubricate plates and discs with positraction lubricant. Alternately position clutch plate and disc on side gear, beginning and ending with clutch plate. Install clutch pack guides on clutch pack lugs. Make sure disc lugs engage with side gear teeth.

4) Remove pinion shaft, gears and thrust washers. Install remaining side gear, clutch pack and shims in case. Install pinion gears and thrust washers. On all models except Corvette, assemble springs in spring retainer and clamp assembly in a vise. Install "C" clamp and bar stock on spring retainer and then install a 1/4" bolt and nut in each front spring. Position spring pack between side gears and remove bar stock and "C" clamp. On Corvette only, install tool (J-22311) to compress clutch pack, secure clutch pack with 1/4" bolts. Partially install pack, remove bolts, and complete pack installation. Remove tool.

2) Select shims of equal thickness as those removed from case, or if old shims are suitable, reinstall them over side gear hub. Lubricate and assemble opposite side gear as outlined above. Install one side gear, clutch pack assembly and shims in case. Position pinion gears and thrust washers on side gears. Install pinion shaft through case and gears.

5) Drive spring pack into side gears sufficiently to retain front springs, then remove 1/4" bolts from springs. Drive spring pack into position. Install pinion shaft and lock screw to retain side gears until axle shaft installation. Check alignment of spring retainer with side gears. Slight movement of spring pack can be made if necessary. Install side bearings and ring gear.

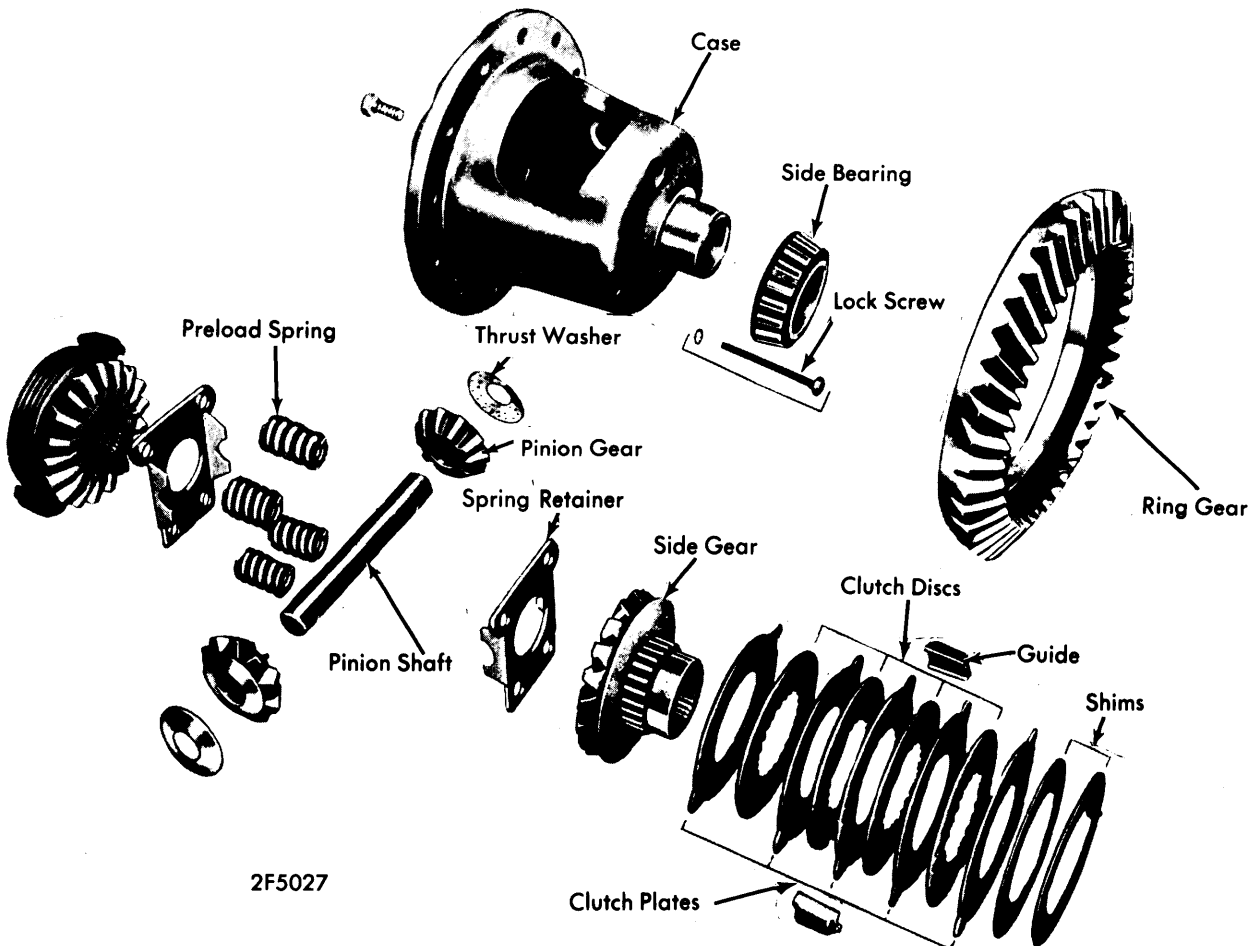

EATON BUILT POSITRACTION UNIT