

GENERAL MOTORS INTEGRAL HOUSING

**Buick
Cadillac Seville
Chevrolet
Oldsmobile
Pontiac**

DESCRIPTION

Semi-floating hypoid gear type with integral housing, with centerline of pinion set below centerline of ring gear. Differential is designed for use with an open drive line and coil or leaf springs. A removable steel cover, bolted to rear of housing, permits service of differential case without removing complete axle assembly from vehicle.

AXLE RATIO & IDENTIFICATION

Ratio code or number is stamped on forward side of axle housing tube (except Corvette). This identification is usually found on right tube, but may also be found on left tube, adjacent to differential housing. On Corvette, number is stamped on bottom edge of differential carrier flange. First two letters designate axle ratio. Third letter designates manufacturer: "B" - Buick, "C" - Chevrolet Buffalo, "G" - Chevrolet Gear and Axle, "K" - G.M. of Canada, "O" - Oldsmobile, "P" - Pontiac. These manufacturer codes also denote axle shaft types; "B" and "O" axles are retained in the axle housing by an outer bearing retainer on axle shaft. "C", "G", "K" and "P" axles are retained in housing by "C" locks positioned in circular grooves machined near inner end of axle shafts.

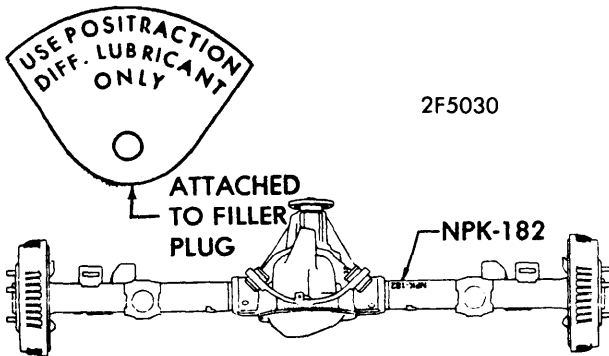

AXLE RATIO CODE LOCATION

Axle Ratio Identification

BUICK

Axle Ratio	Conventional	Positive Traction
2.56-1	DY, FB, AH, UJ	EY, FY, CH, VJ
2.73-1	AC, AL, UU	CC, CL, VU
2.93-1	DJ, YB, UW	EJ, ZB, VW
3.08-1	FG, AZ, AN, KW	FT, CN, LW

CADILLAC SEVILLE

Axle Ratio	Conventional	Positive Traction
2.56-1	MC	MB
3.08-1	MN	MK

Axle Ratio Identification (Cont.)

CHEVROLET

Axle Ratio	Conventional	Positive Traction
2.56-1	AH, KZ, LZ, FB, FY	CH
2.73-1	WA, XA, AC, UT, VT YA, ZA, KA, PA	AC, CC, LA, KY, LY, UA, VA
3.08-1	WC, XC, AD, UZ, VZ	AD, CD, KW, LW, YC, ZC, PC, PW, FG, FT UC, VC

CHEVROLET CHEVETTE

Axle Ratio	Conventional	Positive Traction
3.70-1	QC	
4.11-1	QA	
4.33-1	QB	

CHEVROLET CORVETTE

Axle Ratio	Positive Traction
3.08-1	QA
3.36-1	LR
3.55-1	OB
3.70-1	OC

CHEVROLET VEGA & MONZA

Axle Ratio	Conventional	Positive Traction
2.53-1	HB, HJ	
2.56-1	DY, EY	
2.92-1	HK, HM	
2.93-1	DX, EX	
3.42-1	DU, EU	
3.73-1	DT, ET	
4.10-1	DS, ES	

OLDSMOBILE

Axle Ratio	Conventional	Positive Traction
2.41-1	AA, UN	CA
2.56-1	AH, WF, UJ, DY, FB	CH, XF, VJ, EY, FY
2.73-1	AC, AP, WA, KY	CC, LY, VU, ZA, UU, YA, FC FX, XA
2.92-1	HK	HM
2.93-1	UW, YB, DX	VW, ZB, EX
3.08-1	AD, AR, WC, FG	CD, XC, FT
3.23-1	UX, YD	VX, ZD
3.42-1	DU	EU

PONTIAC

Axle Ratio	Conventional	Positive Traction
2.41-1	AA, WR, WJ, UL, PJ	CA, XR, XJ, VL, PS
2.56-1	AH, WF, KZ, UF	CH, XF, LZ, ZF, FY, YF, FB VF
2.73-1	AC, WA, UT, YA	CC, XA, VT, ZA, PA, FC PU, FX
2.93-1	AF, YB	CF, ZB
3.08-1	AD, YC, PC, FG	CD, ZC, PW, FT
3.23-1	UY	VY, LD

GENERAL MOTORS INTEGRAL HOUSING (Cont.)

PONTIAC ASTRE & SUNBIRD

Axle Ratio	Conventional	Positive Traction
2.53-1	HB	HJ
2.56-1	DY	EY
2.92-1	HK	HM
2.93-1	DX	EX
3.42-1	DU	EU

REMOVAL & INSTALLATION

CORVETTE WHEEL SPINDLE & SUPPORT

See *Corvette Rear* in *SUSPENSION* Section.

AXLE SHAFTS

NOTE — Two types of axle shafts are used: Non "C" lock axles (Type "B" & "O"), and "C" lock axles (Types "C", "G", "K" & "P").

Non "C" Lock Type — **NOTE** — Excessive end play should be corrected by replacing defective parts. Do not attempt to shim. Remove wheels and brake drums, then remove retainer plate from backing plate. Install two screws to hold backing plate in place. Pull axle shafts out using suitable adapter and slide hammer, taking care not to damage oil seal. To install, coat axle shaft with lubricant from sealing surface to about 6" inboard of shaft. Reverse all other removal procedures and tighten retainer plate screws.

"C" Lock Type — Remove wheel, tire, brake drum, and drain rear axle lubricant by removing cover. Remove differential pinion shaft lock screw and pinion shaft. Push axle shaft toward center of vehicle and remove "C" lock from shaft. Remove axle shaft from housing, taking care not to damage seal. To install, reverse removal procedure. **CAUTION** — Axle shaft must be pulled outward after installing "C" lock to properly seat lock in differential side gear.

Corvette Axle Drive Shaft — Disconnect inboard driveshaft trunion from side gear yoke. Bend bolt lock tabs down and remove bolts securing shaft flange to spindle drive flange. Scribe mark on camber adjusting cam and on mounting bracket. Loosen camber adjusting nut and rotate cam so that high point of cam points inboard. Remove driveshaft by withdrawing outboard end first. To install, place driveshaft inboard trunion into side gear yokes and assemble "U" bolts. Rotate yokes so that trunion seats are 90° apart. Install outboard drive flange into spindle drive flange pilot, position lock over bolt holes then install bolts. Tighten bolts then bend lock tabs against flats of bolt head.

COMPANION FLANGE & OIL SEAL

Removal (All Models, Exc. Chevette & Corvette) — Raise vehicle, then remove propeller shaft, marking parts for reassembly reference. Using an INCH lb. torque wrench, measure and record pinion bearing preload by rotating pinion shaft through several revolutions. Mark companion

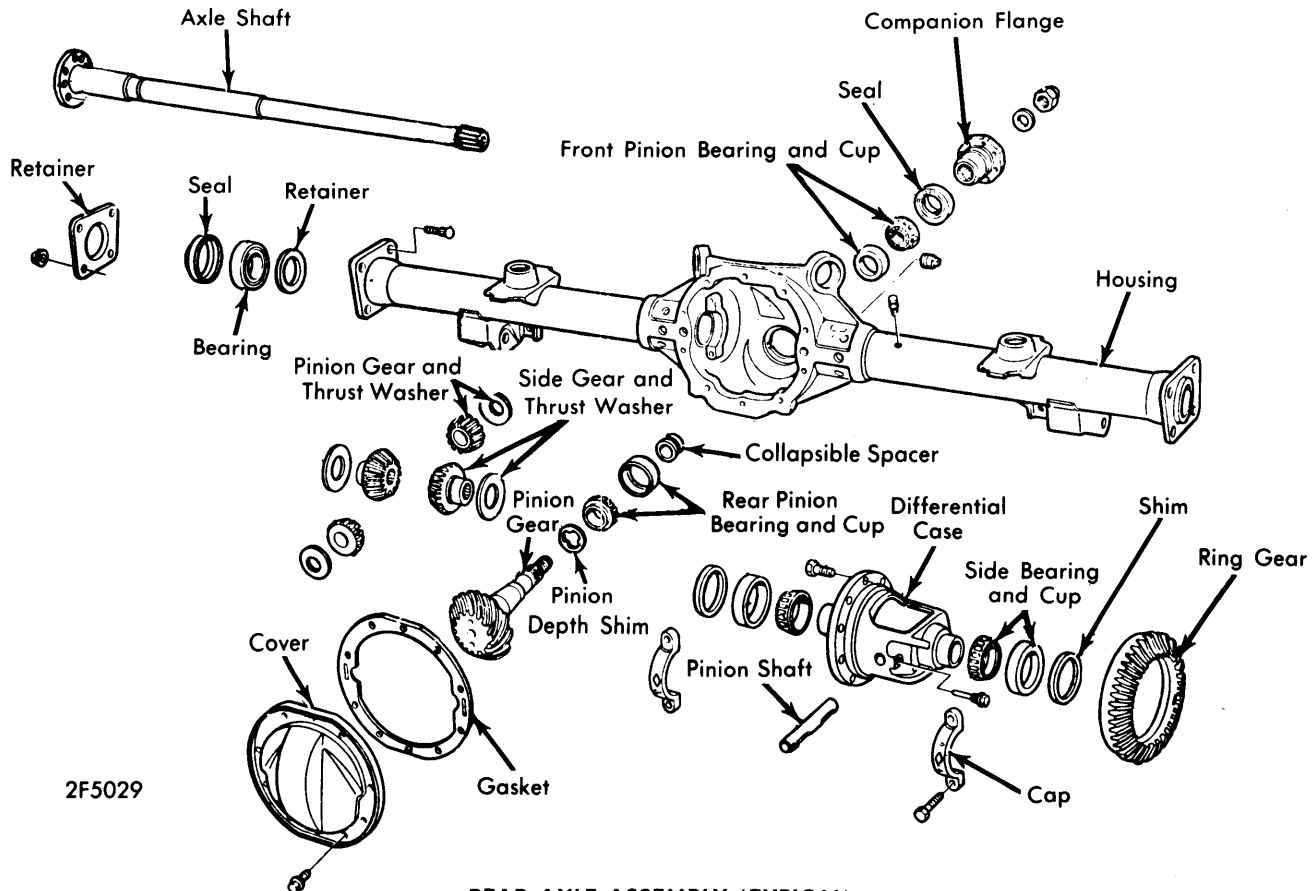

REAR AXLE ASSEMBLY (TYPICAL)

GENERAL MOTORS INTEGRAL HOUSING (Cont.)

flange, nut and pinion shaft for reassembly reference, then remove nut using suitable tools. Remove washer, then use a suitable puller to remove flange. Pry oil seal out of housing using a screwdriver or hammer and chisel.

Installation — Pack seal lip cavity of new seal with lithium base extreme pressure lubricant, then install seal into housing until it seats against internal shoulder. Install companion flange, washer and nut, then tighten nut until all end play is removed. Continue tightening in small increments and checking preload until preload is 1-5 INCH lbs. more than recorded during disassembly. **CAUTION** — Do not exceed original preload by more than 5 INCH lbs. Install propeller shaft.

Removal (Chevette) — **NOTE** — As Chevette rear axle has an extension housing and an extension shaft coupled to front of axle housing, the companion flange is attached to forward end of extension shaft. Instead of a companion flange there is a drive coupling on the end of the pinion shaft. Axle housing oil seal contacts extension shaft instead of companion flange. Raise vehicle, then disconnect propeller shaft from companion flange and remove shaft from transmission. Place a floor stand under front of rear axle housing. Support extension housing and disconnect center support bracket from underbody. Remove bolts attaching extension housing to axle housing and separate them using a screwdriver or lever if necessary. Pry oil seal from axle housing with a screwdriver or a lever.

Installation — Using suitable tool (J-25597), drive oil seal into axle housing. Making sure thrust washer is in place between extension shaft and pinion shaft, slide extension shaft over drive coupling and support front end with a floor stand. Install flange-to-axle housing bolts and connect center support bracket to underbody. Install propeller shaft, being sure thrust spring is in place. Remove floor stands and lower vehicle.

Removal (Corvette) — With wheels hanging freely, disconnect propeller shaft and remove. Disconnect axle drive shafts from carrier. Measure pinion bearing preload, then mark all parts for reassembly reference. Remove companion flange nut and washer, then drive flange off pinion using a brass drift and hammer. Pry oil seal out of carrier.

Installation — Pack cavity between seal lips of seal with lithium base extreme pressure lubricant, then install seal into carrier bore. Lubricate companion flange splines, then tap flange into place on pinion stem. Install washer and nut, then tighten nut until torque exceeds original preload by 1-5 INCH lbs. **CAUTION** — Do not exceed original torque by more than 5 INCH lbs. Install propeller shaft and axle drive shafts.

REAR AXLE ASSEMBLY

Buick — Raise vehicle, then support at frame on both sides. Place floor jack under center of axle housing and lift until it just starts to raise housing. On Skyhawk, disconnect torque arm at differential. Disconnect rear universal joint from pinion flange, marking parts for reassembly reference. Disconnect parking brake cables at equalizer, and rear brake hose at floor pan. On coil spring equipped vehicles, disconnect shock absorbers at lower end and upper control arms at axle housing. Lower axle housing, remove springs, then disconnect lower control arms at axle housing and remove axle assembly from vehicle. On vehicles with leaf springs, disconnect shock absorbers at lower end, then support vehicle on jack stands at frame in front and at rear of springs. On Estate wagon, disconnect right side exhaust system by removing exhaust hanger screw to rear frame crossmember. Remove lower spring plate attaching nuts, front and rear spring attaching bolts, then

remove axle assembly from vehicle. To install, reverse removal procedure and note following: On coil spring vehicles, control arm bolts must be tightened with suspension in normal load position.

Seville — Raise vehicle on a hoist and support axle so it may be raised or lowered. Raise axle assembly so that all tension is removed from springs and disconnect rear leveling valve overtravel lever from link. Hold lever down in exhaust position to deflate shock absorbers. Remove lower shock absorber nut and bolt and position shock out of the way. Disconnect parking brake cables at equalizer and at all cable clamps. Loosen spring front eye bushing to retaining bracket bolt. Remove spring front bracket attaching bolts. Lower axle sufficiently to remove bolt and bracket. Remove "U" bolt and "T" bolts nuts attaching lower spring plate to axle and stabilizer bar brackets. Remove upper and lower rubber spring pads and spring plate. Support spring with jack stand and remove both nuts from rear shackle. Separate shackle and remove spring. Remove clip securing brake hose to body and disconnect hose from brake line. Remove stabilizer bar link nuts with retainers and bushings. Mark propeller shaft for reassembly and disconnect from axle pinion flange. Hang propeller shaft aside clear of rear axle. Lower rear axle and remove from vehicle.

To install, raise rear axle into position. **NOTE** — While installing springs, loosely tighten all nuts and bolts. After complete installation, then torque nuts and bolts to specifications. Place front spring eye to mounting bracket and install bolt with head toward center of vehicle. Place a $\frac{3}{16}$ " flat washer under nut (torque is 105 ft. lbs.). Position upper spring shackle bushings in frame and install bolt (torque is 50 ft. lbs.). Install bushing halves in rear spring eye. Slide spring into shackles and install bolt (torque is 50 ft. lbs.). Raise front end of spring and position bracket to underbody. Check to see that spring indexes with slot in underbody. Install bracket screws (torque is 30 ft. lbs.). Position upper spring cushion between spring and axle bracket with cushion ribs aligned with bracket locating ribs. Place lower mounting plate over locating dowel on lower spring pad and install nuts (torque is 45 ft. lbs.). Position stabilizer bar brackets to lower spring plate and install nuts and bolts (torque is 30 ft. lbs.). Install lower shock mounts (torque is 45 ft. lbs.). Install parking brake cables and mounting clamps with cable running under leaf springs. Hold rear leveling valve overtravel lever in "UP" position to inflate shock absorbers. Connect overtravel lever to link. Now tighten all nuts and bolts to specifications. Install front stabilizer bar eyes over links. Install bushings, retainer and nuts and tighten to 150 INCH lbs. Connect brake hoses to brake lines with all mounting clamps installed. Install propeller shaft to pinion flange with marks aligned and tighten screws to 70 ft. lbs. Lower vehicle to ground and bleed brakes.

Chevrolet (Exc. Corvette) — Raise vehicle, then install lifting device under axle. On Monza, disconnect torque arm at differential. On Chevette disconnect stabilizer bar, tie rod and rear axle extension bracket. **CAUTION** — Support axle extension so that it does not swing down rapidly when disconnected from body bracket. Remove propeller shaft and disconnect shock absorbers. Disconnect upper control arms from axle on models with coil springs. Remove wheels, brake drums, disconnect brake lines from clips on axle tubes, then remove axle shafts. Remove brake backing plates and wire to frame. On models with coil springs, remove lower control arm pivot bolts, then lower axle assembly out of vehicle. For leaf spring suspension, remove lower spring brackets, then shift axle assembly to clear springs. To install, reverse removal procedure.

GENERAL MOTORS INTEGRAL HOUSING (Cont.)

Corvette — Raise vehicle, then remove exhaust system behind front crossmember. Disconnect axle driveshafts at carrier, and carrier front mounting bracket bolt. Remove propeller shaft. Disconnect strut rod bracket from underside of carrier and lower bracket with strut rods attached. Loosen spring-to-carrier bolts, then remove cover bolts and allow lubricant to drain. Remove carrier. To install, insert two ½-13 x 1¼" bolts (heads cut off and slotted at unthreaded ends) into two below-center carrier bolt holes, one on each side. Insert one ⅜-18 x 1¼" bolt (head cut off and slotted at unthreaded end) into underside of carrier. These aligning studs aid in installation of carrier and strut rod bracket. Install gasket and sealer to carrier and cover. Mount carrier to cover and install six cover bolts, then remove two aligning studs and install remaining cover bolts. Position strut rod bracket to carrier, install three bolts, then remove aligning stud and install remaining bolt. Tighten spring-to-carrier bolts. Install propeller shaft, axle drive shafts, and exhaust system.

Oldsmobile — Raise vehicle and support at rear frame torque boxes. Remove fender panels, rear wheels, brake drums, and axle shafts. On Custom Cruiser wagons, remove resonator assembly and tail pipe. On Starfire, disconnect torque arm at differential. Disconnect brake lines from clips and remove bolt from junction block on axle housing. Disconnect shock absorbers and brake backing plates from axle and wire to frame. On vehicles with coil springs, disconnect upper control arms at axle housing, remove springs, disconnect lower control arms from axle tubes, then remove axle housing from vehicle. On models equipped with leaf springs, remove "U" bolts attaching spring to axle housing. On Custom Cruiser wagons, remove propeller shaft and support front of housing at companion flange. While supporting spring, remove shackle from rear of spring, then lower spring. Remove bolt and nut from front spring bushing, then remove each spring. Remove sup-

port at companion flange, then remove axle assembly. On Omega, shift axle assembly to clear springs, and lower out of vehicle.

Pontiac — Raise vehicle, remove propeller shaft, rear wheels, and brake drums. On Catalina and Grand Ville wagons, remove "kick-under" tail pipe and resonator assembly. Drain rear axle lubricant, then remove axles. Disconnect brake lines from clips and remove bolt from junction block on axle. Disconnect shock absorbers from axle tubes, and brake backing plates, and wire to frame. On vehicles with coil springs, disconnect upper control arms at carrier housing, remove springs, disconnect lower control arms from axle tubes, and remove axle assembly. On vehicles with leaf springs, remove shackle from rear of springs and lower. Remove bolt and nut from front spring bushings, then remove assembly from vehicle. To install, reverse removal procedure. **NOTE** — Vehicle must be at curb height when tightening control arms on coil spring vehicles.

DISASSEMBLY

CORVETTE

Remove side gear yoke snap rings and remove yokes. Mark differential bearing caps and housing for reassembly reference, then remove caps and differential case from housing. Remove side bearing shims and mark for reassembly. Remove companion flange nut, flange and seal, then remove pinion shaft and rear bearing. Remove front pinion bearing. Remove side gear yoke seals from housing then remove yoke bearings. Disassemble differential by removing pinion pin lock screw, pinion pin, pinions and side gears. Remove ring gear only if gear set is to be replaced or side bearings are to be replaced. Remove pinion bearing cups from housing, then press pinion shaft out of rear bearing and note size of depth shim pack.

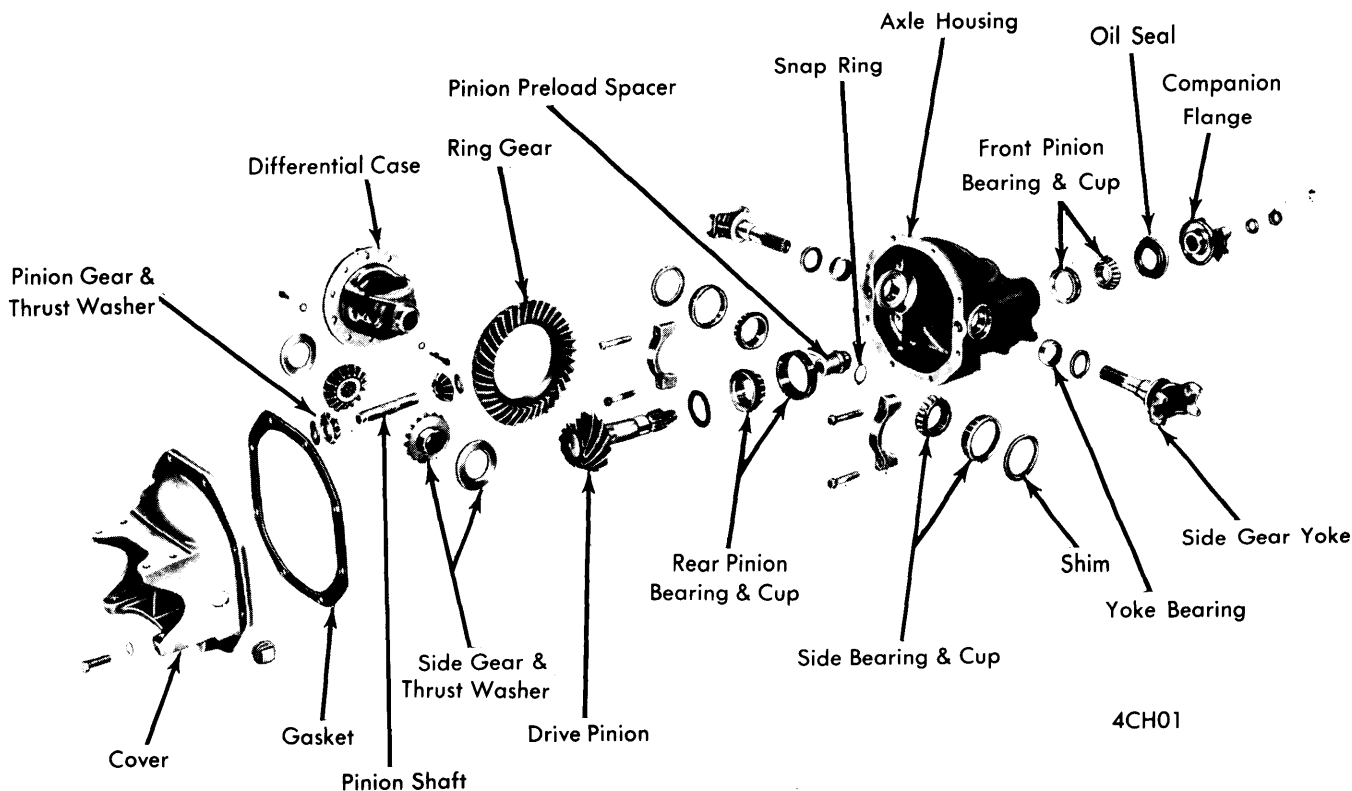

CORVETTE REAR AXLE ASSEMBLY

GENERAL MOTORS INTEGRAL HOUSING (Cont.)

ALL MODELS (EXCEPT CORVETTE)

NOTE — Check ring gear and pinion backlash and pinion bearing preload before disassembly. Following procedure is with axle shafts removed.

On models with "O" type axles, remove cover and allow fluid to drain. On all models, mark differential bearing caps and housing for reassembly reference, then remove caps and pry differential from housing. Remove differential bearing cups and shims, marking for reassembly. Keep cups and shims with corresponding bearing caps. If necessary, use a suitable press to remove bearings from differential case. On "O" type axles, remove pinion shaft lock pin, pinion shaft, pinions, and side gears. If necessary, remove left hand thread drive gear bolts, then tap gear from case using a brass drift. Remove pinion nut, drive coupling (Chevette) or companion flange (All Others) and washer, then remove pinion shaft and front bearing. If necessary, remove pinion bearing cups from housing using a brass drift. Press pinion shaft out of rear bearing and note thickness of pinion depth shim pack.

REASSEMBLY

PINION SHAFT & BEARINGS

Pinion Depth Adjustment — 1) Drive pinion rear bearing shim thickness, controlling pinion depth of mesh with ring gear, must be determined whenever a new axle housing, ring and pinion set, or pinion bearings and races are installed. Depth of mesh is determined by using suitable Pinion Setting Gauge tool set. **NOTE** — Checking procedure for different axles is the same, however, tool component combinations vary between axles. See illustration and Tool Application Table for tool numbers and location of components used. Insure all parts are clean and free of burrs, then proceed as follows:

2) If removed, install pinion bearing races, then install lubricated pinion bearings. Position gauge plate and rear pinion bearing pilot (if used) on preload stud, then install through far pinion bearing and through front pinion bearing and front pinion bearing pilot. Install hex nut until snug, then rotate bearings to insure proper seating. Hold preload stud stationary with a wrench on flats, then tighten hex nut until 20 INCH lbs. are required to rotate bearings.

3) Mount side bearing gauging discs on ends of arbor, then place arbor into carrier making sure discs are properly seated. Install side bearing caps and bolts, then tighten bolts to avoid movement. Position dial indicator on mounting post of arbor, with contact button resting on top surface of plunger. Preload dial indicator one-half revolution, then tighten in this position.

4) Place plunger onto gauging area of gauge plate. Rock plunger rod slowly back and forth across gauging area until dial indicator reads greatest deflection, then set indicator to zero. Repeat rocking action several times to verify setting. Once zero reading is obtained, swing plunger until it is removed from gauging area. Dial indicator will now read required pinion shim thickness for a "nominal pinion". Record this reading.

5) Check drive pinion for painted or stamped markings on pinion stem, or a stamped code number on small end of pinion gear. If marking is found to be a plus or minus number (for instance +2 or -5), add or subtract that many thousandths from indicator reading. This will then be thickness of rear pinion bearing shim pack. **NOTE** — If no markings are found on pinion, use dial indicator reading as shim thickness.

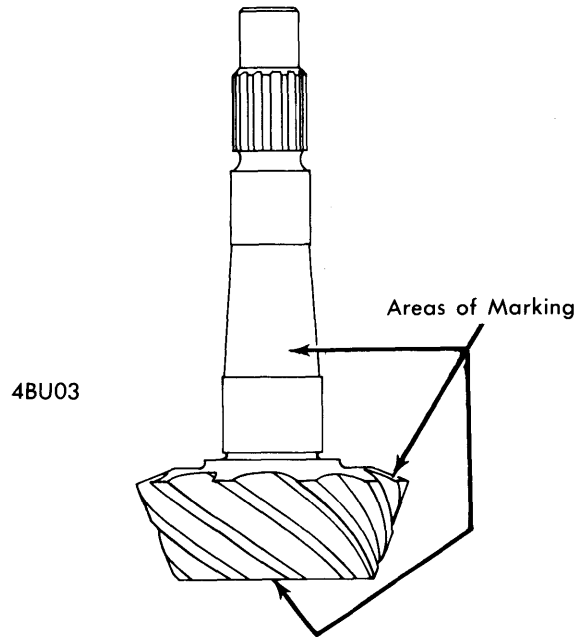

PINION MARKING LOCATIONS

6) If marking is found to be a code number, see following chart, then add or subtract that many thousandths from dial indicator reading. **NOTE** — All production pinions are "nominal pinions" and may not be marked "45".

Pinion Code	Correction Required
40.....	Subtract .005"
41.....	Subtract .004"
42.....	Subtract .003"
43.....	Subtract .002"
44.....	Subtract .001"
45.....	No Correction
46.....	Add .001"
47.....	Add .002"
48.....	Add .003"
49.....	Add .004"
50.....	Add .005"

7) Remove bearing caps and gauging tools from housing. Place selected shim pack on drive pinion, then install lubricated pinion bearing onto pinion shaft using a suitable press.

GENERAL MOTORS INTEGRAL HOUSING (Cont.)

TOOL APPLICATION

Tool Location

Tool Part Number

NOTE - See illustration for component location.

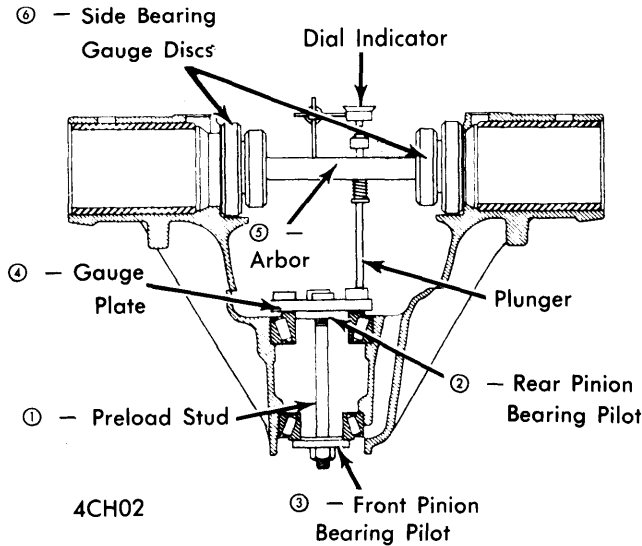

TOOL ASSEMBLY (TYPICAL)

Tool Location

Tool Part Number

BUICK 7 1/2" RING GEAR

①	J-21777-43
②	J-21777-35
③	J-23597-12
④	J-23597-11
⑤	J-23597-1
⑥	J-21777-45

BUICK 8 1/2" RING GEAR

①	J-8619-13
②	J-21777-35
③	J-5647-37
④	J-21777-29
⑤	J-21777-1
⑥	(Left Side) J-8619-10 (Right Side) J-5647-46

BUICK 8 7/8" & 9 3/8" RING GEAR

①	J-8619-13
②	J-21777-8
③	J-5647-37
④	J-21777-29
⑤	J-21777-1
⑥	(Left Side) J-5647-40 (Right Side) J-5647-41

CADILLAC SEVILLE 8 1/2" RING GEAR

①	J-21777-43
②	J-21777-35
③	J-21777-42
④	J-21777-29
⑤	J-21777-1
⑥	(Small Step) J-21777-45

CHEVROLET NOVA & VEGA 6 1/2" & 7 1/2" RING GEAR

①	Not Available
②	Not Used
③	J-23597-5
④	J-23597-3
⑤	J-23597-6
⑥	J-23597-4

CHEVROLET MONZA 7 1/2" RING GEAR

①	J-21777-43
②	Not Used
③	J-21777-42
④	J-23597-11
⑤	J-23597-1
⑥	J-21777-45

CHEVROLET 8 1/2" RING GEAR

①	J-21777-43
②	J-21777-35
③	J-21777-42
④	J-21777-29
⑤	J-21777-1
⑥	(Small Step) J-21777-45

CHEVROLET 8 7/8" RING GEAR

①	J-21777-43
②	J-21777-8
③	J-21777-42
④	J-21777-29
⑤	J-21777-1
⑥	(Large Step) J-21777-45

CHEVROLET CORVETTE

①	J-21777-43
②	J-21777-35
③	J-21777-42
④	J-21777-36
⑤	J-21777-1
⑥	(Large Step) J-21777-45

GENERAL MOTORS INTEGRAL HOUSING (Cont.)

Tool Location

Tool Part Number

Tool Location

Tool Part Number

CHEVROLET CHEVETTE

①	Not Available
②	Not Used
③	J-23597-21
④	J-23597-20
⑤	J-23597-6
⑥	J-23597-4

OLDSMOBILE 7 1/2" RING GEAR

①	J-8619-3
②	Not Used
③	J-8619-12
④	J-23597-11
⑤	J-21777-1
⑥	J-21777-45

OLDSMOBILE 8 1/2" RING GEAR

①	J-8619-13
②	Not Used
③	J-8619-12
④	(Step A) J-21777-21
⑤	J-21777-1
⑥	J-8619-10

OLDSMOBILE 8 7/8" RING GEAR

①	J-8619-13
②	Not Used
③	J-8619-12
④	(Step B) J-21777-2
⑤	J-21777-1
⑥	J-21777-3

OLDSMOBILE 9 3/8" RING GEAR

①	J-8619-13
②	J-21777-8
③	J-8619-12
④	(Step B) J-21777-21
⑤	J-21777-1
⑥	J-21777-3

PONTIAC 6 1/2" & 7 1/2" RING GEAR

①	J-21777-43
②	J-23597-13 (6 1/2"), J-23597-12 (7 1/2")
③	J-8619-12
④	J-23597-11
⑤	J-23597-1
⑥	J-23597-4

PONTIAC 8 1/2" RING GEAR

①	J-8619-13
②	Not Used
③	J-8619-12
④	J-21777-26
⑤	J-21777-1
⑥	J-8619-10

PONTIAC 8 7/8" RING GEAR

①	J-8619-13
②	J-21777-8
③	J-8619-12
④	J-21777-2
⑤	J-21777-1
⑥	J-21777-3

Pinion Installation & Preload Adjustment — Install a new collapsible spacer over pinion stem, then position pinion in housing. While holding pinion forward, carefully drive front pinion bearing onto pinion shaft until a few threads are exposed. Install new oil seal, then drive coupling (Chevette) or companion flange (All Others), washer and nut, and tighten until end play is removed. Rotate pinion several times to seat bearings, then check preload using an INCH lb. torque wrench. Continue tightening nut and checking preload until proper preload is obtained (see specifications). **CAUTION** — Do not back off nut to lessen preload. If preload is exceeded, a new collapsible spacer must be installed and nut retightened until proper preload is obtained.

DIFFERENTIAL

Case Reassembly — Place ring gear onto case, install new bolts, then alternately tighten bolts to pull ring gear into position on case. Place side gear thrust washers over side gear hubs, then install assemblies into case in their original position. Install pinions and thrust washers into case, then install pinion shaft and lock bolt. Using suitable installing tools, install side bearings onto differential case.

Side Gear Yoke Bearings and Seals (Corvette) — Using suitable installing tool (J-9973), install bearing into carrier bore, then drive bearing in until it is fully seated. Install new seal in seal bore outboard of bearing.

Side Bearing Preload (Buick & Pontiac, Exc. 6 1/2" Ring Gear) — Install differential into housing. Use service type adjusting shims of stamped steel and cast spacer to make up a shim pack for each side totaling same thickness as original production shims. Slip left shim pack into position so that steel shim is between bearing and spacer, then install right spacer, and drive right steel shim into position with a hammer. Install side bearing caps and tighten. Rotate case several complete turns to seat bearings, then measure preload with an INCH lb. torque wrench at pinion nut. If side bearing preload is not correct (see specifications), increase or decrease shim thickness on each side by .002" for each 10 INCH lb. change required.

Side Bearing Preload (Chevrolet, Exc. 6 1/2" Ring Gear) — Install differential into housing. Slip suitable gauging tool (J-22779) between left bearing race and carrier housing, then tighten adjusting nut until a noticeable drag is felt. Tighten gauge locking bolt, then remove and measure gauge plates. Subtract thickness of service spacer (.170") from thickness of plates to determine size of shim to be used. Install spacer and shim, then install bearing cap. Repeat procedure for right bearing. Add .004" to each bearing shim for proper preload.

Side Bearing Preload (All with 6 1/2" Ring Gear) — Install differential assembly into housing. Place ring gear tightly against drive pinion, and make sure bearings are properly seated. Install service spacer (.160"), service shim, and feeler gauge on ring gear side of unit. Thickness of feeler gauge must be sufficient to produce slight drag when moved between

GENERAL MOTORS INTEGRAL HOUSING (Cont.)

carrier and service shim. Repeat procedure for right bearing. Measure dimensions. Add together dimensions of service shim, spacer and feeler gauge. Add .004" to right and left dimensions proper preload shim.

Side Bearing Preload (Oldsmobile) — 1) NOTE — Side bearings preload adjustment is to be made before pinion is installed. If pinion is already installed, remove ring gear from case. Measure original side bearing preload shims, then select a service shim (.170") and service spacer for a total thickness slightly less than original shim thickness. Install differential case into housing. Install service spacer between each bearing cup and housing with chamfered edge of spacer against housing. Install left bearing cap loosely so that differential case is free to move.

2) With left bearing race and spacer against side of housing, install both right and left service shims selected previously,

between right bearing race and service spacer. Insert progressively larger feeler gauges until a noticeable drag is felt. Point just before drag is felt is correct feeler gauge thickness. Add total of service shims and feeler gauge. This is total shim thickness to be used. Select two shims whose total thickness is equal to total just determined. Remove carrier, install ring gear (if removed), then reinstall carrier with correct shim pack selected. Adjust differential backlash, then preload differential bearings by increasing side bearing shim thickness by .004" on each side.

Ring Gear & Pinion Backlash — Check backlash with a dial indicator mounted to axle housing at four locations around ring gear. Variation should not exceed .002". If backlash is not correct (see specifications), adjust side bearing shims as necessary. After all adjustments have been completed, tighten all bolts, then make a tooth contact pattern check to insure correct assembly.

SPECIFICATIONS

Application	Clearance or Torque
Pinion Bearing Preload ①	
Buick (Exc. Skyhawk)	
New Bearings	20-25 INCH Lbs.
Used Bearings	10-15 INCH Lbs.
Cadillac Seville	
New Bearings	15-30 INCH Lbs.
Used Bearings	5-10 INCH Lbs.
Chevrolet (Exc. Corvette, Monza, Vega)	
New Bearings	15-30 INCH Lbs.
Used Bearings	5-10 INCH Lbs.
Corvette	
New Bearings	20-25 INCH Lbs.
Used Bearings	5-10 INCH Lbs.
Chevette	
New Bearings	5-11 INCH Lbs.
Used Bearings	3-6 INCH Lbs.
Oldsmobile, Pontiac (Exc. Astre & Sunbird)	
New Bearings	24-32 INCH Lbs.
Used Bearings	8-12 INCH Lbs.
Astre, Monza, Skyhawk, Skylark, Sunbird, Vega	
New Bearings	10-25 INCH Lbs.
Used Bearings	8-12 INCH Lbs.
Side Bearing Preload	
Buick	
New Bearings	② 35-40 INCH Lbs.
Used Bearings	② 20-25 INCH Lbs.
Chevrolet	③ Slip Fit Plus .008"
Oldsmobile	④ Slip Fit Plus .008"
Pontiac	③ Slip Fit Plus .008"
Ring Gear Backlash	
Buick006-.008"
Chevrolet, Pontiac Astre & Sunbird	
Buick Skyhawk & Skylark005-.008"
Oldsmobile, Pontiac (Exc. Astre & Sunbird) ..	.005-.009"

- ① — Measured with new seal without ring gear installed.
- ② — Total assembly preload measured at pinion nut.
- ③ — .004" added to each side to preload bearings.
- ④ — .004" added to each side after backlash set.

TIGHTENING SPECIFICATIONS

Application	Ft. Lbs.
Ring Gear-to-Case Bolt	
Buick	85
Corvette, Monza, Vega	50
Cadillac, Chevrolet, Pontiac	90
Chevette	48
Oldsmobile	95
Bearing Cap Bolt	
Corvette, Monza, Vega, Chevette	55
Buick, Cadillac, Chevrolet	60
Oldsmobile	75
Pontiac	70
Pinion Shaft Lock Bolt	
Buick, Pontiac	15
Cadillac, Chevrolet	25
Corvette, Oldsmobile	20
Monza, Skyhawk, Skylark, Vega	150 INCH Lbs.
Housing Cover Bolts	
Buick, Oldsmobile	30
Cadillac, Chevrolet, Pontiac	25
Corvette	50
Monza, Skyhawk, Skylark, Vega	20
Chevette	22
Universal Joint Flange-to-Pinion Flange	
Astre, Monza, Sunbird, Vega	14
Buick, Chevrolet, Corvette	
Single Joint	15
C.V. Joint	75
Cadillac	70
Oldsmobile	
Single Joint	20
C.V. Joint	95
Pontiac	
Single Joint	14
C.V. Joint	85
Corvette Axle Drive Shafts	
To Spindle	75
To Yoke	15
Universal Joint Flange-to-Companion Flange	
Chevette	16