

Drive Axles

FORD MOTOR CO. INTEGRAL HOUSING (STANDARD TYPE)

Bobcat
Mustang
Pinto

DESCRIPTION

An integral type housing, hypoid design, with centerline of pinion set below centerline of ring gear. Semi-floating axle shafts are retained in housing by ball bearings and a bearing retainer at axle housing outer ends.

AXLE RATIO & IDENTIFICATION

A metal tag stamped with model designation and gear ratio is secured to one of the rear cover-to-housing bolts.

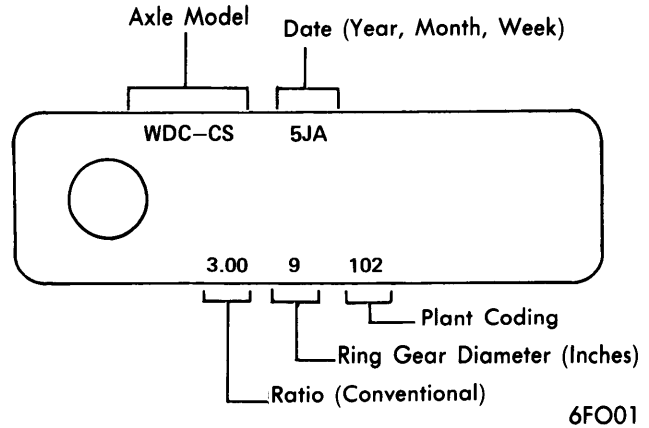

REAR AXLE IDENTIFICATION TAG

Axle Ratio Identification

Axle Ratio	Code	Ring Gear Diameter
3.18-1	WGF-U, WGF-R2, WGF-AA	6 ³ / ₄ "
3.40-1	WGF-H	6 ³ / ₄ "
3.40-1	WGF-K	6 ³ / ₄ "
3.55-1	WGF-R	6 ³ / ₄ "
3.55-1	WGF-N	6 ³ / ₄ "

REMOVAL & INSTALLATION

AXLE SHAFTS & BEARINGS

1) Remove wheel assembly from brake drum, then back off rear brake shoe adjusters. Remove brake drum-to-axle shaft flange nuts and remove drum. Disconnect wheel bearing retainer (work through hole in axle shaft flange), and remove axle shaft from housing with a suitable sliding hammer type puller. Remove backing plate and secure it to frame.

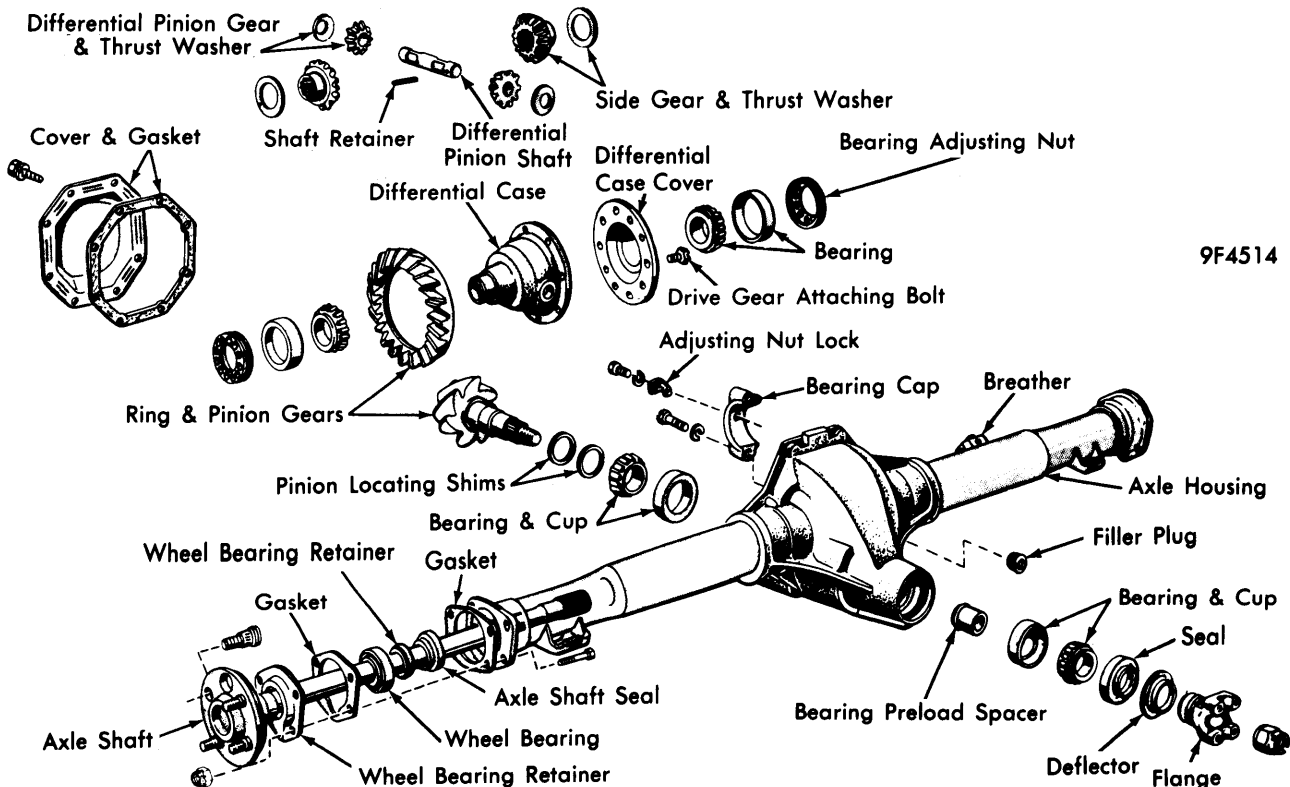

FORD MOTOR CO. INTEGRAL HOUSING ASSEMBLY

FORD MOTOR CO. INTEGRAL HOUSING (Cont.) (STANDARD TYPE)

2) Remove seal from axle housing with a suitable puller. To remove bearing from shaft, nick bearing retainer deeply with a chisel, using care not to damage shaft, and remove retainer. Press bearing from shaft using arbor press and suitable tool to hold and support bearing. When installing seal in axle housing, coat outside edge of new seal with sealing compound, then install seal in housing with suitable tool, making sure sealing lips face inward and seal is seated against shoulder in housing. Place retainer plate and new gasket on axle shaft and press new bearing on shaft, seating it firmly against shaft shoulder. Press a new bearing inner retainer on shaft, seating it firmly against bearing. **CAUTION** — Do not try to press bearing and inner retainer on shaft at the same time.

REAR AXLE ASSEMBLY

Raise vehicle and support on underbody, then loosen housing cover and drain lubricant. Disconnect propeller shaft at pinion flange and shock absorbers at axle housing. Remove axle shafts. Remove hydraulic brake "T" fitting from housing (do not open system), then remove brake line from retainer clip on housing. Remove both brake backing plates from housing and support out of way. Support axle housing on a jack, then remove spring plates and "U" bolts. Remove axle assembly from under vehicle. To install, reverse removal procedure.

PINION FLANGE & OIL SEAL

Raise vehicle on hoist and make scribe marks on propeller shaft universal joint, drive pinion flange and end of pinion stem. Remove driveshaft, rear wheels and brake drums. Using an INCH lb. torque wrench on pinion nut, measure pinion bearing preload through several revolutions of pinion flange. Using suitable holding tool, hold flange and remove pinion nut and washer. Using suitable pullers, remove pinion flange and drive pinion oil seal. Inspect flange for damage, repair as necessary. Using suitable tool, install drive pinion oil seal. Install flange, washer and nut, then tighten, taking frequent preload readings until preload is at original setting. **CAUTION** — Under no circumstances should pinion nut be backed off to lessen preload. If this is done, a new pinion bearing spacer must be installed and nut retightened until proper preload is obtained. In addition, universal joint flange must never be hammered on, or power tools used.

OVERHAUL

DIFFERENTIAL CASE & DRIVE PINION

Removal — Remove carrier cover and drain lubricant. Remove axle shafts, driveshaft, differential bearing adjusting nut locks and mark case and caps for reassembly, remove differential bearing caps. Remove differential case and bearing cups. **NOTE** — Caps must be kept with respective bearing cones. Remove pinion flange using suitable puller. With soft-faced hammer, drive pinion out of front bearing cone and remove through rear of carrier casting. Drive front pinion bearing cone and pinion flange seal out front of carrier casting. Do not remove pinion bearing cups from carrier casting unless cups are worn or damaged, or unless pinion bearings are to be replaced. If cups are to be replaced, remove with a brass drift.

Disassembly — Mark differential case cover and ring gear for reassembly. Remove ring gear attaching bolts and tap ring gear off case with soft-faced hammer. Remove left side of differential case. Using a drift punch, drive out differential pinion shaft lock pin. Using a brass drift, drive out pinion shaft. Remove gears and thrust washers. Use arbor press to remove rear pinion bearing off pinion shaft. Measure and record thickness of pinion depth shim (located under rear bearing).

Inspection — Clean all parts thoroughly in suitable cleaning solvent. When replacing ring gear and pinion, note original factory shim is correct thickness to adjust for variations in both carrier casting and original gear set dimension. To select correct shim thickness for new gear set, note following: Using micrometer, measure thickness of original shim removed from axle and use same thickness in reassembly of replacement carrier unit or drive pinion. If further shim change is necessary, it will be noted in a tooth pattern check. If original shim is lost, use a nominal shim (.030") and make a tooth pattern check. **CAUTION** — Ring gear and pinion are installed as a matched set. Be sure same identifying number (painted in white) appears on ring gear and pinion head.

Reassembly — Lubricate all parts with rear axle lubricant. Place side gears and thrust washers in case. Place pinion gears and thrust washers exactly opposite each other in case openings and in mesh with side gears. Turn pinions and thrust washers until holes in pinion gears align with pinion shaft holes in case. Drive pinion shaft into case, aligning shaft lock pin hole with pin hole in case and install lock pin. Position two case halves together and place ring gear on case. Apply a small amount of Loctite to bolts, then install and tighten.

Installation — 1) Install shim and pinion bearing rear cone on shaft and press firmly against pinion shaft shoulder. Place new pinion bearing preload spacer on pinion shaft. **NOTE** — End of spacer with largest diameter (shortest end) should go on pinion first. Failure to do this will cause loss of preload. Lubricate pinion bearings and install front bearing cone in housing, followed by pinion oil seal. Insert drive pinion flange into seal and hold firmly against front bearing cone. From rear of carrier, insert pinion shaft through flange. Install washer and pinion nut and gradually tighten to remove end play. Continue to tighten nut, checking preload often. Rotate pinion several revolutions after each tightening step.

2) Apply thin coat of lubricant on bearing bores so differential bearing cups will move easily. Place cups on differential bearings and set differential case in carrier housing. **CAUTION** — Be sure to align timing marks on ring gear and pinion if so equipped. Slide case assembly along bores until slight backlash is felt between gears. While holding case in place, set adjusting nuts in bores so that they just make contact with bearing cups. Position bearing caps on carrier pedestals and tighten bolts, turning adjusting nuts to insure they are free. Tighten bolts to 40-55 ft. lbs. to be sure cups and adjusting nuts are seated. Loosen bolts and retighten to 5 ft. lbs. and make backlash and bearing preload adjustment.

Drive Axles

FORD MOTOR CO. INTEGRAL HOUSING (Cont.) (STANDARD TYPE)

BACKLASH & SIDE BEARING PRELOAD

NOTE — Left adjusting nut is on ring gear side of carrier, right nut is on pinion side.

1) Loosen right nut until it is away from bearing cup. Tighten left nut until ring gear is just forced into pinion with no backlash, then rotate pinion to insure there is no binding. Recheck right nut at this time to make sure it is still loose. *NOTE* — Tightening left nut moves ring gear into pinion to decrease backlash, tightening right nut moves ring gear away.

6F9016

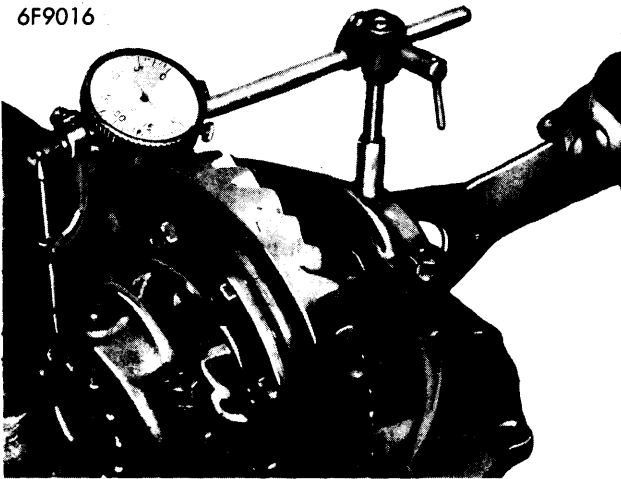

**DIAL INDICATOR INSTALLATION TO ADJUST
BEARING PRELOAD**

2) Install a dial indicator as shown in illustration. Tighten right nut two notches past where it first contacts bearing cup, then turn differential several rotations to seat bearings. Then, loosen right nut until it just contacts bearing cup. Tighten left nut until case is spread .004-.008" (new bearings) or .003-.005" (original bearings). Tighten differential bearing cap bolts.

3) Measure backlash at several teeth around ring gear. If backlash is not within specification, loosen one nut and tighten opposite nut an equal amount, to move ring gear away from or toward pinion gear. *NOTE* — When moving adjusting nuts, final movement should always be in a tightening direction. Recheck differential bearing preload, then make a gear tooth pattern check to insure correct assembly.

SPECIFICATIONS

ADJUSTMENT SPECIFICATIONS

Ring Gear Backface Runout003"
Side Gear Thrust Washer Thickness030-.032"
Pinion Gear Thrust Washer Thickness030-.032"
Differential Bearing Preload (New)004-.008"
(Used)003-.005"
Nominal Pinion Shim Thickness030"
Ring Gear-to-Pinion Backlash008-.012"
Maximum Backlash Variation Between Teeth003"

TIGHTENING SPECIFICATIONS

Application	Ft. Lbs.
Bearing Cap Bolt	40-55
Bearing Adjusting Nut Lock Bolt	12-25
Ring Gear Attaching Bolts	45-60
Minimum Torque (Pinion Nut) For Pinion Bearing Preload	① 140
Pinion Bearing Preload (Collapsible Spacer) New Bearings	② 17-27 INCH lbs.
Used Bearings	② 6-12 INCH lbs.

① — If preload exceeds specifications before this torque is obtained, install a new spacer.

② — With oil seal.