

## AMERICAN MOTORS

### American Motors, All Models

**NOTE** — For models with limited slip differential, see American Motors 7 $\frac{1}{16}$ " Twin-Grip Differential or Spicer Trac-Lock Differential in this section.

### DESCRIPTION

Semi-floating hypoid gear type with differential carrier integral with rear axle housing. Hotchkiss drive used on all models.

### AXLE RATIO & IDENTIFICATION

Axle ratio codes are located on axle tube housing boss, adjacent to dowel hole.

#### Axle Ratio Identification

| Code | Axle Ratio     | Ring Gear Diameter  |
|------|----------------|---------------------|
| A    | 3.54-1 (11/39) | 8- $\frac{7}{8}$ "  |
| B    | 3.15-1 (13/41) | 8- $\frac{7}{8}$ "  |
| C    | 2.87-1 (15/43) | 8- $\frac{7}{8}$ "  |
| D    | 3.91-1 (11/43) | 8- $\frac{7}{8}$ "  |
| E    | 3.58-1 (12/43) | 7- $\frac{9}{16}$ " |
| F    | 3.08-1 (13/40) | 7- $\frac{9}{16}$ " |
| G    | 3.31-1 (13/43) | 7- $\frac{9}{16}$ " |
| H    | 2.73-1 (15/41) | 7- $\frac{9}{16}$ " |
| K    | 2.53-1 (17/43) | 7- $\frac{9}{16}$ " |

### REMOVAL & INSTALLATION

#### HUBS & DRUMS

**Removal** — Remove axle shaft nuts, then raise and support vehicle. Remove wheel and tire, drum retaining screws, then remove drum from hub. Attach a suitable puller (J-1644) and remove hub from axle shaft. **NOTE** — Use of a knock-out type puller on axle shaft may cause damage to rear wheel bearings or thrust block.

**CAUTION** — Procedures for reinstalling original hub and installing a new hub and drum assembly differ.

**Installation (Original Hub)** — Align keyway in hub with axle shaft key, slide hub onto axle shaft, then install axle shaft washer and nut. Install drum, retaining screws and wheel. Lower vehicle onto wheels, then tighten axle shaft nut. If cotter pin hole is not aligned, tighten nut to next castellation, then install cotter pin.

**NOTE** — When a new axle shaft is installed, a new hub and drum must also be installed. However, a new hub and drum may be installed onto an original axle shaft if serrations on shaft are not worn or damaged.

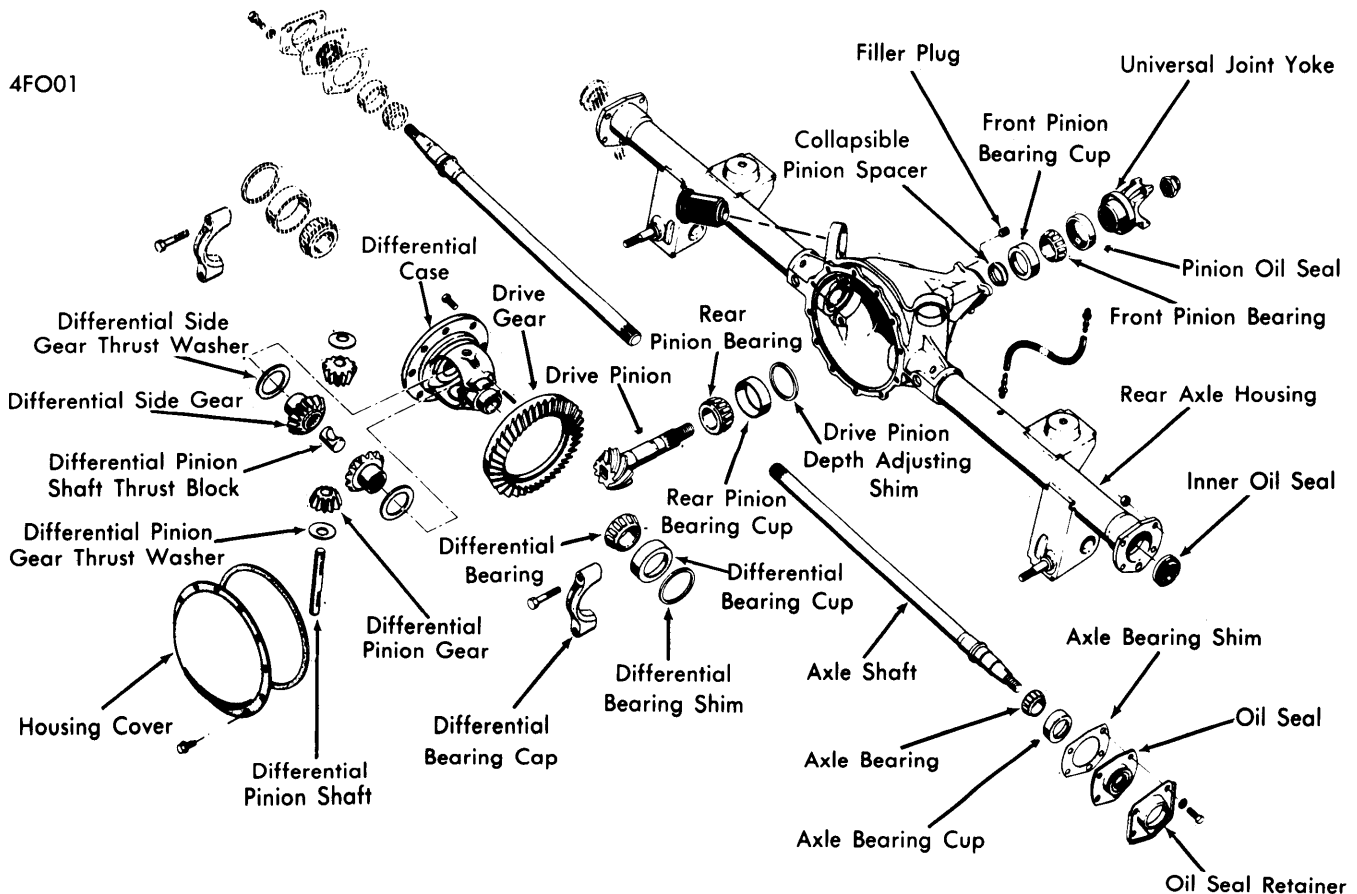

### AMERICAN MOTORS REAR AXLE ASSEMBLY

## AMERICAN MOTORS (Cont.)

**Installation (New Hub and Drum)** — Align keyway in hub with axle shaft key, slide hub and drum onto axle shaft as far as possible, then install two lubricated thrust washers and axle shaft nut. Install wheel and lower vehicle. Tighten axle shaft nut until distance from hub outer face to axle shaft outer end is 1.17" on vehicles with  $7\frac{1}{16}$ " axles, or 1.30" on vehicles with  $8\frac{7}{8}$ " axles. Remove axle shaft nut and one thrust washer, then reinstall nut and tighten. If cotter pin hole is not aligned, tighten nut to next castellation, then install cotter pin.

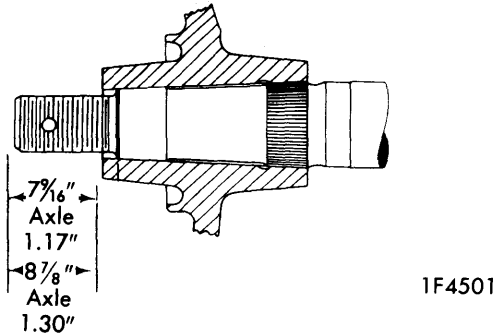

HUB INSTALLATION MEASUREMENT

## AXLE SHAFTS &amp; BEARINGS

**Removal** — Remove rear wheel, drum and hub. Disconnect parking brake cable at equalizer and brake tube at wheel cylinder, then remove brake support plate assembly, oil seal, and axle shims from axle shaft. **NOTE** — End play shims are located on left axle shaft only. Using suitable puller, remove axle shaft from axle tube, then remove and discard oil seal. Remove bearing from axle shaft using arbor press.

**Installation** — 1) Pack bearing with suitable wheel bearing grease, then press onto axle shaft with small diameter of cone toward outer tapered end of shaft. Coat inner axle shaft seal with light lubricating oil, then coat outer surface of seal metal retainer with a suitable sealing material. Using suitable tool, install oil seal, then install axle shaft, and outer bearing cup. Install original shims, oil seal assembly, and brake support plate, then install and tighten bolts. **NOTE** — Oil seal and retainer is located between axle tube flange and support plate on vehicles with 9" brakes, or on outside of brake support plate on vehicles with 10" brakes.

**End Play Adjustment** — Strike each axle shaft with lead hammer to seat bearing cups against support plate. Attach a suitable end play checking tool (J-2092) to end of shaft, install dial indicator to support plate or tool, then check end play by pushing and pulling on shaft. End play should be .004-.008", .006" desired. Add shims to left side only to increase end play, remove shims to decrease end play.

## REAR YOKE &amp; PINION OIL SEAL

**Removal** — Raise and support vehicle, remove wheels, then remove propeller shaft, marking parts for reassembly reference. Using an INCH lb. torque wrench, rotate pinion several revolutions and record torque required to turn drive pinion. Using suitable tools, remove and discard pinion nut. Mark drive pinion shaft and yoke for reassembly reference, then remove yoke using suitable pullers. Using suitable tool (J-9233 or J-7583), remove pinion oil seal.

**Installation** — Coat new seal with rear axle lubricant, then install using suitable tool (J-22661). Install rear yoke, aligning marks made at disassembly, install NEW pinion nut and tighten to remove end play only. **CAUTION** — Do not overtighten. Using an INCH pound torque wrench, check tor-

que required to turn drive pinion. If preload torque is less than desired (5 INCH lbs. over disassembly reading), tighten pinion nut slightly and recheck preload. Repeat procedure until desired preload is obtained. **CAUTION** — Do not loosen then retighten, or overtighten pinion nut. If desired preload is exceeded, a new collapsible pinion spacer sleeve must be installed and drive pinion preload reset.

## REAR AXLE ASSEMBLY

**Pacer, Gremlin & Hornet** — Remove axle shaft nuts prior to raising vehicle, raise and support vehicle, then remove axle housing cover, rear wheels, hubs and drums. Disconnect rear parking brake cables at equalizer, then remove brake support plates. **NOTE** — Retain shims located between left support plate and axle tube. Remove axle shafts, disconnect propeller shaft, rear shock absorbers at axle and brake line at body floorpan bracket. Remove rear spring "U" bolts, then remove axle assembly from vehicle. To install, reverse removal procedure, then bleed hydraulic system and adjust parking brake cables.

**Matador** — Remove axle shaft nuts prior to raising vehicle, then raise vehicle and remove axle housing cover to drain lubricant. Marking parts for reassembly reference, disconnect propeller shaft and parking brake cables at equalizer. **NOTE** — Left cable is routed to upper long end of equalizer. Disconnect brake lines at support plate, then remove wheels, hubs, drums, brake support plates, seals, axle shafts and bearings. Support axle assembly, then disconnect shock absorbers at axle tubes and lower assembly until it is supported by control arms. Pull axle tubes down to remove springs, then disconnect upper and lower control arms and remove assembly from vehicle. To install reverse removal procedure, then bleed hydraulic system and adjust parking brake cables.

## OVERHAUL

## DISASSEMBLY

**NOTE** — It is not necessary to remove axle assembly to perform overhaul. However, underbody should be cleaned to prevent dirt contamination.

1) Remove rear cover and drain lubricant, then remove axle shafts, brake drums and hubs. Mark bearing caps for reassembly reference, then remove caps and pry differential case from housing. Tie bearing shims to their respective caps and cups to prevent misplacement. Remove differential side bearings using a suitable puller. Remove ring gear from case, then remove pinion shaft lock pin, pinion shaft, thrust block, pinion gears, side gears and thrust washers from case.

2) Remove pinion nut, then use suitable tools to remove rear yoke and seal. Using a soft faced hammer, tap end of pinion shaft to free front bearing cone from shaft, then remove bearing. Remove drive pinion and rear bearing from housing, then discard collapsible spacer. Drive out front and rear bearing cups and keep pinion depth shims (located behind rear bearing cup) for reassembly.

## INSPECTION

Inspect all parts for wear or damage. Pinion shaft should be a press fit to a .010" loose fit in case. Clearance of differential gear in case bore should not exceed .007". Clean all parts thoroughly, replace as necessary.

## AMERICAN MOTORS (Cont.)

### REASSEMBLY

**Drive Pinion** — Press rear bearing on pinion stem with large diameter of roller cage toward gear. Clean housing bearing bores, then place shim in rear bearing bore and install rear bearing cup. *NOTE* — When a new gear set is being installed, use original depth shim as a starting point. Chamfered side of shim must be installed to bottom side of rear bearing cup bore. Center shim to prevent tipping bearing cup. Install front bearing cup into housing, install drive pinion through rear bearing cup, then install front bearing, rear yoke, and original pinion nut. Tighten nut to remove bearing end play only. *NOTE* — A new nut and collapsible spacer are not installed at this time as pinion will be removed after a depth measurement.

**Drive Pinion Depth** — Observe numbers painted on drive pinion and ring gear. First number on pinion must match number on ring gear. *NOTE* — If numbers do not match, gear set is not a matched set and should not be installed. Second number on pinion is pinion depth variance. If number is preceded by a plus sign, add that number to standard pinion depth. If number is preceded by a minus sign, subtract that number from standard pinion depth. Standard pinion depth on  $7\frac{1}{16}$ " axles is 2.095". Standard pinion depth on  $8\frac{7}{8}$ " axles is 2.547". Result of addition or subtraction will be desired pinion depth. Record for future reference.

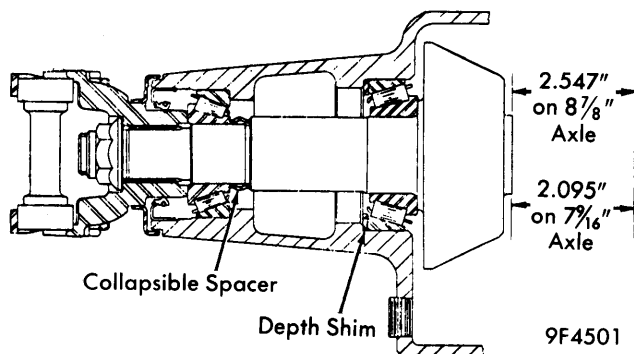

### PINION DEPTH & PRELOAD SHIM LOCATION

2) Mount gauge arbor tool (J-5223-4) and discs (J-5223-23 on  $8\frac{7}{8}$ "; J-6381-2 on  $7\frac{1}{16}$ "). Install gauge assembly with discs fully seated in housing bores, then install bearing caps and tighten bolts. Position gauge block (J-5223-20) against end of drive pinion with clamp bar and screw (J-5223-24). Loosen thumbscrew in end of gauge block and allow spring loaded plunger to contact arbor. Tighten thumbscrew, taking care not to disturb position of plunger. Remove gauge block and measure distance from end of anvil to top of plunger head using a two to three inch micrometer. Record this measured pinion depth for future reference.

3) Remove gauging tools, drive pinion and rear bearing cup. Remove drive pinion depth shim and record thickness. Add shim thickness to measured pinion depth. From this total subtract desired pinion depth. The result represents correct shim thickness to be installed. *NOTE* — Replacement gears with a pinion variance marking of more than  $+.009$ " should be returned for replacement. Install correct thickness shim in rear bearing bore and install rear bearing cup.

**Drive Pinion Bearing Preload** — Install collapsible spacer and front bearing on drive pinion, then install oil seal rear yoke and nut. Using suitable tools, tighten pinion nut only enough to remove bearing end play. Gradually tighten nut to collapse spacer and preload bearings. *CAUTION* — Do not overtighten. Using an INCH lb. torque wrench, measure torque required to turn drive pinion. If preload torque is less than desired, tighten pinion nut slightly and recheck preload. Continue procedure until desired preload is obtained. *CAUTION* — Do not exceed preload torque. Do not back off nut to lessen preload. If preload torque is exceeded, replace collapsible spacer and adjust preload to correct torque.

**Assembling Differential Carrier** — 1) Using suitable installing tools, install differential bearings onto case. Install thrust washers on differential gears (oil pocket side toward gear), then install gears into bores in differential case. Install thrust washers behind differential pinion gears, then mesh gears with differential gears so holes in gears are opposite and in line with each other. Roll gears around until differential pinion gear holes are aligned with shaft holes in case.

2) Install thrust block through a differential gear, aligning hole in block with pinion shaft holes. Install pinion shaft, with lock pin hole in shaft aligned with lock pin hole in case. Measure any existing clearance between differential gears and case, using two feeler gauges on opposite sides of one gear. Clearance should be zero.

3) Oversize differential gear thrust washers (.010") may be installed where required. Tolerance is acceptable if 15 ft. lbs. or less of torque applied to either side gear will rotate internal gears. To check, install an axle shaft and use a torque wrench to turn shaft. *NOTE* — If gears require replacement, replace differential and pinion gears as a set, then drive lock pin into place.

**Adjusting Differential Bearings** — 1) Place bearing cup over each differential bearing, then install differential case assembly in axle housing. Install a shim on each side between bearing cup and housing. Use .080" shims on  $8\frac{7}{8}$ " axles, or .142" shims on  $7\frac{1}{16}$ " axles. Install bearing caps and tighten bolts finger tight, then mount dial indicator to housing so that button of indicator touches drive gear face of differential case. Using two screwdrivers, pry between shims and housing. Pry assembly to one side, zero indicator, then pry assembly to opposite side and read indicator. *NOTE* — Do not zero or read indicator while prying.

2) Amount read on indicator is amount of shim to be added to arrive at a no preload and no end play condition. Shims are available from .080-.110" in .002 variations for  $8\frac{7}{8}$ " axles, and from .142-.174" in .002" for  $7\frac{1}{16}$ " axles. When all side play is eliminated, check drive gear face of case for runout. Runout should not exceed .002". Remove case from housing, retain shims used to eliminate side play.

**Drive Gear Installation** — Place drive gear on differential case, then bolt drive gear to differential case. Two  $\frac{3}{8}$ " x 1" cap screws installed in opposite holes may be used as guides to pull gear into position. Tighten cap screws evenly.

# Drive Axles

## AMERICAN MOTORS (Cont.)

**Backlash Adjustment** – Install differential assembly in housing using shims selected to remove side play. Tighten bearing cap screws evenly. Attach a dial indicator to housing so that button of indicator contacts drive side of a tooth of drive gear, and at a right angle to it. Rock drive gear and note movement on dial indicator. Backlash should be .005-.009", with .008" desired. To increase backlash, install a thinner shim on drive gear side and a thicker shim on opposite side. To decrease backlash, reverse procedure, however, do not change total thickness of shims.

**Differential Bearing Preload** – 1) Differential bearings are preloaded by increasing each shim thickness by .004". Install differential bearing shims in axle housing bearing bores. Assemble bearing cups on bearings (cups should completely cover rollers), then position differential so that bearings just start in axle housing bearing bores. Keep assembly square in housing and push in as far as possible. Using a soft hammer, tap outer edge of bearing cups until seated in housing. **CAUTION** – Do not distort shims by hammering them into housing.

2) Install bearing caps, aligning marks made at disassembly, then install and tighten bolts. Preloading differential bearings may change backlash setting, therefore recheck backlash and correct if necessary. After all adjustments have been made, make a gear tooth pattern check to insure correct assembly. Install propeller shaft, axle shafts, bearings, seals, brake support plates, hubs and drums, reversing disassembly procedures. Fill rear axle with suitable lubricant.

### AXLE ASSEMBLY SPECIFICATIONS

|   |                 |
|---|-----------------|
| <b>Pinion Bearing Preload</b>             |                 |
| 7- <sup>9</sup> / <sub>16</sub> " .....   | 15-25 INCH lbs. |
| 8- <sup>7</sup> / <sub>8</sub> " .....    | 17-28 INCH lbs. |
| <b>Differential Bearing Preload.....</b>  |                 |
|   | .008"           |
| <b>Drive Gear to Pinion Backlash.....</b> |                 |
|   | .005-.009"      |
| <b>Case Flange Run-out .....</b>          |                 |
|   | .002" Max.      |
| <b>Gear to Case Preload</b>               |                 |
| 7- <sup>9</sup> / <sub>16</sub> " .....   | 0-120 INCH lbs. |
| 8- <sup>7</sup> / <sub>8</sub> " .....    | 0-180 INCH lbs. |
| <b>Axle Shaft End Play .....</b>          |                 |
|   | .004-.008"      |

### TIGHTENING SPECIFICATIONS

| <b>Bolt or Nut</b>                      | <b>Ft. Lbs.</b> |
|---|-----------------|
| Pinion Nut.....                         | 200             |
| Housing Cover Screws.....               | 14              |
| Brake Support Plate .....               | 32              |
| Rear Hub to Axle Shaft Nut.....         | Min. 250        |
| <b>Differential Bearing Cap</b>         |                 |
| 7- <sup>9</sup> / <sub>16</sub> " ..... | 57              |
| 8- <sup>7</sup> / <sub>8</sub> " .....  | 87              |
| <b>Drive Gear to Case Screw</b>         |                 |
| 7- <sup>9</sup> / <sub>16</sub> " ..... | 52              |
| 8- <sup>7</sup> / <sub>8</sub> " .....  | 105             |
| Universal Joint "U" Bolts .....         | 13              |