

## 200" & 250" 6 CYLINDER

GENERAL SPECIFICATIONS						
Engine	Net HP At RPM	Torque (Ft. Lbs. at RPM)	Compr. Ratio	Bore	Stroke	Displ. Cu. Ins.
200" 1-Bbl.	.....	.....	.....	3.68"	3.13"	200
250" 1-Bbl.	.....	.....	.....	3.68"	3.91"	250

### ENGINE IDENTIFICATION

Engine may be identified from the official Vehicle Identification Number. Number is stamped on a metal tab fastened to instrument panel close to windshield on drivers side of car and visible from outside. The Identification number contains eleven digits. Example: 6S91L100001. The first digit determines model year and fifth digit establishes engine identification.

Engine	Engine Code
200" .....	T
250" .....	L

### ENGINE REMOVAL

See Engine Removal at end of ENGINE Section.

### CYLINDER HEAD

**Removal** — Drain cooling system and disconnect upper radiator hose at engine. Disconnect muffler inlet pipe and remove gasket. Disconnect accelerator retracting spring,

accelerator rod, kickdown rod and linkage (at bellcrank assembly). Disconnect fuel lines, vacuum lines, all wires and remove crankcase ventilation system. Remove rocker cover, rocker arm shaft and push rods. Remove cylinder head bolts and cylinder head.

**Installation** — Clean all gasket surfaces and apply suitable sealer to both sides of new steel gasket. **NOTE** — Composition type gaskets do not need sealer. Position gasket on block and install cylinder head. Tighten cylinder head bolts in three steps.

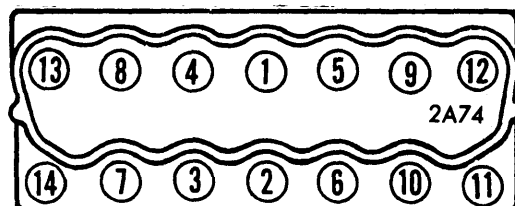

CYLINDER HEAD TIGHTENING SEQUENCE

VALVES							
Engine & Valve	Head Diam.	Face Angle	Seat Angle	Seat Width	Stem Diameter	Stem Clearance	Valve Lift
200 & 250" Int.	1.651"	44°	45°	.060-.080"	.3100-.3107"	.0008-.0025"	① .3720
Exh.	1.390"	44°	45°	.070-.090"	.3098-.3105"	.0010-.0027"	② .3720

① — On 250" with manual transmission, valve lift is .3850"

② — On 250" with manual transmission, valve lift is .3530"

### VALVE ARRANGMENT

E-I-I-E-I-E-E-I-E-I-I-E

### VALVE GUIDE SERVICING

To ream guides for installation of valves with oversize stems, always use reamers in sequence and reface valve seat after valve guide is reamed. Reamers are available .003" oversize with standard diameter pilot; .015" oversize with .003" oversize pilot; .030" oversize with .015" oversize pilot.

### VALVE STEM OIL SEALS

Cup type used on all valves. Install cupped side down, below upper spring retainer.

VALVE SPRINGS			
Engine	Free Length	PRESSURE (LBS.)	
		Valve Closed	Valve Open
200"	1.79"	51-57 @ 1.59"	142-158 @ 1.222"
250"	1.79"	61-67 @ 1.55"	142-158 @ 1.18"

### VALVE SPRINGS

**Removal** — 1) Remove air cleaner. Remove crankcase ventilation regulator valve from rocker arm cover and remove cover. Remove spark plug on cylinder to be serviced.

2) Loosen rocker arm shaft support bolts two turns at a time until valve spring pressure is relieved. Remove push rods of cylinder to be serviced. Install air line with adapter in spark plug hole.

3) Tighten rocker arm shaft bolts just enough to seat shaft supports on cylinder head. Push rocker arm to one side and secure in position. **NOTE** — To move end rocker arms, it is necessary to remove retaining pin and spring washer and slide rocker arm off the shaft.

4) Using suitable valve spring compression tool (T65P-6513-A), compress valve and remove retainer locks, sleeve, spring retainer and the valve spring. **NOTE** — If air pressure fails to hold valve closed during this operation, remove cylinder head for inspection. Remove valve stem seal. Do not remove air pressure as this may allow valve to fall into cylinder if piston has been forced to bottom of the cylinder.

## 200" & 250" 6 CYLINDER (Cont.)

**Installation** - 1) Install a new valve stem seal. Position spring over the valve and install spring retainer and sleeve. Compress valve spring and install valve spring retainer locks.

2) Apply lubriplate to both ends of push rod, valve and push rod ends of the rocker arm, and to valve stem tip. Install push rods ensuring that lower end is positioned in valve lifter push rod cup. Slide rocker arm into position.

3) Secure rocker arm shaft. Turn off air and remove air line and adapter. Install spark plug and wire. Install rocker arm cover with new gasket and secure. Install regulator valve and air cleaner.

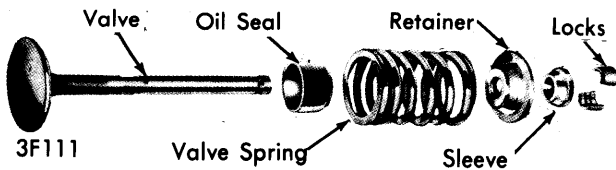

**VALVE ASSEMBLY**

### VALVE SPRING INSTALLED HEIGHT

Valve spring ends must be square within  $\frac{5}{64}$ ". Installed height of springs (measured from spring contact area on head to underside of spring retainer) should be within specifications. If height is greater than maximum allowable, install .030" spacers as necessary to meet specifications. **NOTE - Do not install spacers unless necessary. Excess use of spacers will result in over stressing the valve and spring and overloading the camshaft lobes, causing spring breakage and worn camshaft lobes.**

#### Valve Spring Installed Height

Engine	Height
200" Int. & Exh. ....	$1\frac{1}{16}$ " - $1\frac{1}{32}$ "
250"	
Int. ....	$1\frac{1}{16}$ " - $1\frac{1}{32}$ "
Exh. ....	$1\frac{1}{32}$ " - $1\frac{3}{64}$ "

### ROCKER ARM ASSEMBLY

See illustration for arrangement of parts. All rocker arms and rocker arm shaft must be lubricated with oil before installation. End plugs must have cup side facing out, and oil holes in shaft must be facing downward.

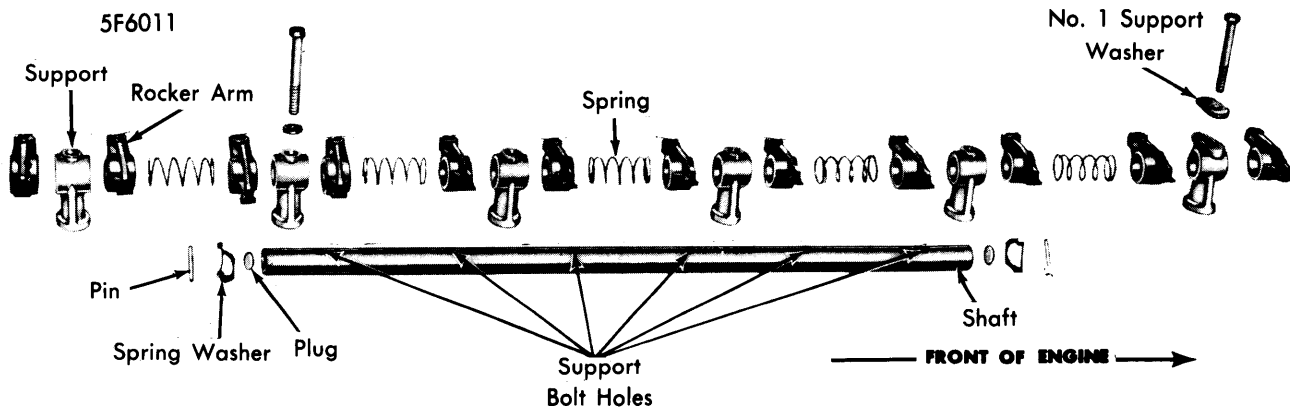

**ROCKER ARM & SHAFT ASSEMBLY**

### HYDRAULIC VALVE LIFTER ASSEMBLY

Lifters must be serviced as assemblies only; their parts are not interchangeable. Leakdown rate on all lifters should be 5-50 seconds at .0625" plunger travel with a load of 50 pounds.

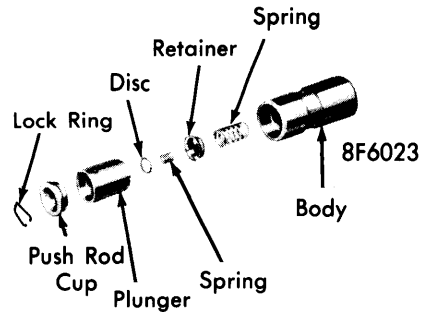

**VALVE LIFTER ASSEMBLY**

### HYDRAULIC VALVE LIFTER ADJUSTMENT

Turn crankshaft so that No. 1 piston is on TDC after compression stroke and check valve clearance of the valves shown in Table 1 as follows: Using suitable tool (T-6513-K), apply pressure to push rod end of rocker arm to slowly bleed down the valve lifter until plunger is completely bottomed. Hold lifter in this position and check the clearance between rocker arm and valve stem tip with a feeler gauge. If clearance is less than specification, install an undersize push rod. If greater than specification, install an oversize push rod. After checking all valves in Table 1, rotate crankshaft so No. 6 piston is on TDC after compression stroke and check clearance on valves shown in Table 2. Desired rocker arm clearance is .079-.129". Acceptable clearance is .079-.209".

**Table 1**

No. 1 Int. ....	No. 1 Exh.
No. 2 Int. ....	No. 3 Exh.
No. 4 Int. ....	No. 5 Exh.

**Table 2**

No. 3 Int. ....	No. 2 Exh.
No. 5 Int. ....	No. 4 Exh.
No. 6 Int. ....	No. 6 Exh.

## 200" & 250" 6 CYLINDER (Cont.)

PISTONS, PINS, RINGS						
Engine	PISTONS	PINS		RINGS		
	Clearance	Piston Fit	Rod Fit	Rings	End Gap	Side Clearance
200 & 250"	.0013-.0021"	.0003-.0005"	Press Fit	1&2 3	.008-.016" .015-.055"	.002-.004" Snug

### OIL PAN

See Oil Pan Removal at end of ENGINE Section.

### PISTON & ROD ASSEMBLY

**Removal** - Remove ridge at top of cylinder bores using suitable ridge cutter. *NOTE* - Keep tops of pistons covered during this procedure. Rotate crankshaft and inspect connecting rods and rod caps for cylinder identification. Identify if necessary. Remove rod cap and push each piston and rod assembly out top of cylinder bore. *NOTE* - Be careful not to nick crankshaft journals. Install rod caps on mating rods.

**Installation** - 1) Oil piston rings and cylinder walls with light engine oil. Ensure that ring gaps are properly spaced on piston (see illustration) and install ring compressor on piston.

2) Insert rod and piston assembly into cylinder bore and guide rod over crankshaft journal. *NOTE* - Notch on piston head should be towards front of engine. Tap piston into cylinder bore using a wooden handle and install rod cap and tighten. Repeat procedure for each piston assembly.

### FITTING PISTONS

Measure piston at centerline of piston pin bore 90° to pin bore axis. Measure cylinder bore at right angles to centerline of crankshaft, below ring travel.



2F346

PISTON & ROD ASSEMBLY

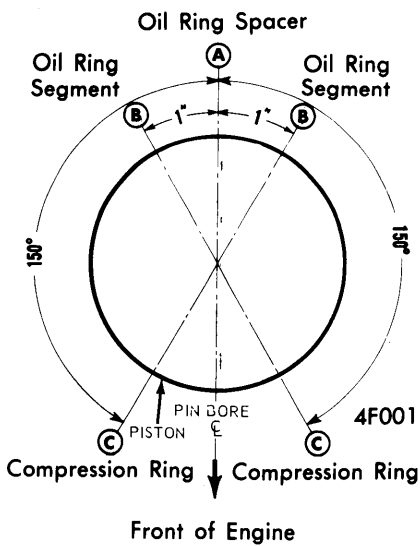

PISTON RING GAP SPACING

### PISTON PINS

**Removal** - Use arbor press and suitable tool; press out pin.

**Installation** - Light tap with mallet may be needed to start pin into piston and rod assembly. Using arbor press and suitable tool, press pin into piston and rod assembly until pin centers in piston (see illustration).

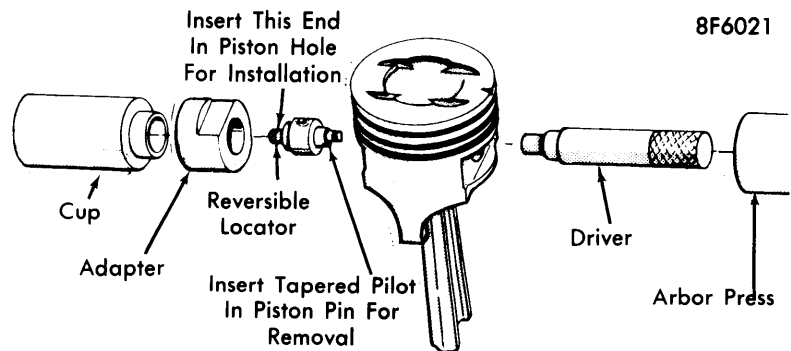

8F6021

PISTON PIN REMOVAL & INSTALLATION

## CRANKSHAFT MAIN & CONNECTING ROD BEARINGS

Engine	MAIN BEARINGS				CONNECTING ROD BEARINGS		
	Journal Diam.	Clearance	Thrust Bearing	Crankshaft End Play	Journal Diam.	Clearance	Side Play
200"	2.2482-2.2490"	.0008-.0015"	No. 5	.004-.008"	2.1232-2.1240"	.0008-.0015"	.0035-.0105"
250"	2.3982-2.3990"	.0008-.0015"	No. 5	.004-.008"	2.1232-2.1240"	.0008-.0015"	.0035-.0105"

## 200" &amp; 250" 6 CYLINDER (Cont.)

## MAIN &amp; CONNECTING ROD BEARINGS

**Removal** — Remove cylinder head and oil pan to obtain access to main and connecting rod bearings and then proceed as follows:

- 1) To change connecting rod bearings, remove rod caps. Inspect connecting rod caps for cylinder identification so caps are installed in same position upon assembly. With crankshaft lined up in center of cylinder bore, push piston towards top of cylinder block a small amount and remove upper half of bearing.
- 2) Before removing main bearing caps, mark for identification so installation position is correct. Remove nuts on main bearing caps and remove cap. Remove upper half of bearing by inserting suitable tool (6331) in oil hole of crankshaft and slowly rotating crankshaft in direction of engine rotation, forcing out upper half of bearing.

**Installation** — 1) Determine crankshaft journal clearance in bearing by Plastigage method. Place a jack under counterweight adjoining bearing being checked so weight of crankshaft will not compress Plastigage and provide an erroneous reading. If bearing clearance is excessive, a .001" or .002" undersize bearing half may be used in combination with a standard size bearing half. If .002" undersize bearings are used on more than one journal, they may be positioned in cylinder block rather than bearing cap. If standard and .002" undersize combination do not bring bearing clearance within specified limits, crankshaft will have to be refinished and undersize bearings installed.

2) After bearings have been fitted, apply a light coat of engine oil to journals and bearings. With crankshaft throw to bottom of stroke and upper half of bearing installed, push piston down until connecting rod bearing seats on journal. Install connecting rod cap and tighten. Check connecting rod side clearance.

3) To install upper main bearing, lubricate bearing with engine oil and place plain end of bearing over shaft on locking tang side of block. Partially install bearing so suitable tool (6331) can be inserted in journal oil hole. Rotate crankshaft slowly in opposite direction of engine rotation until bearing tang is seated. Remove bearing tool. Install bearing cap and tighten.

## THRUST BEARING ALIGNMENT

Install all bearing caps except thrust bearing cap and tighten. Install thrust bearing cap with bolts finger tight. Pry crankshaft to front of engine and pry thrust bearing cap to rear of engine. While holding crankshaft forward, tighten thrust bearing cap bolts. Check crankshaft end play.

## REAR MAIN BEARING OIL SEAL

**Removal** — Upper and lower seals may be installed without removing crankshaft as follows: Remove main bearing cap and loosen remaining bearing caps allowing crankshaft to drop down slightly. Remove old seals and rear seal pin (if equipped). Discard pin.

**Installation** — Clean seal groove in cylinder block and cap. Dip new seal halves in engine oil. Install upper seal in groove with under cut side of seal towards front of engine. Allow approximately  $\frac{3}{8}$ " to protrude below parting surface. **CAUTION** — Make sure no rubber is shaved from outside of seal during installation. Apply suitable sealer to parting faces of cap and block. Install lower seal in bearing cap with under cut side toward front of engine. Allow approximately  $\frac{3}{8}$ " to protrude above parting surface. Install cap and tighten.

## ENGINE FRONT COVER

**Removal** — Drain crankcase and cooling system. Remove radiator, fan, belt and pulley. Remove condenser attaching bolts and position condenser forward. **NOTE** — Do not disconnect refrigerant hoses. Remove crankshaft damper using suitable tool (T-58P-6316-B). Remove oil pan and then front cover.

**Installation** — Clean all gasket surfaces. Use suitable sealer on gaskets and position on cylinder block. Install timing chain snubber in front cover. Use suitable tool (T61K-6019-A) to center cover on crankshaft. Install bolts and tighten.

## FRONT COVER OIL SEAL

**Removal & Installation** — Drive out oil seal with a pin punch to remove. Clean recess in front cover. Coat new seal with grease and install. Drive seal in until it is fully seated in recess. Inspect seal to ensure that spring is properly positioned in seal.

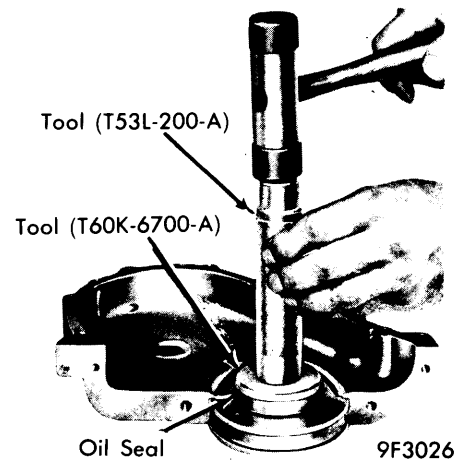

INSTALLING FRONT COVER OIL SEAL

CAMSHAFT			
Engine	Journal Diam.	Clearance ①	Lobe Lift
200 & 250"	1.8095-1.8105"	.001-.003"	② .2450"

① — End play is .001-.007".

② — On 250" engine with manual transmission, lobe lift is .2530" for intake and .2320" for exhaust.

## TIMING CHAIN

**Inspection** — With front cover removed, rotate crankshaft in counterclockwise direction to take up slack on left side of chain. Establish a reference point on engine block and measure from this point to chain. Rotate crankshaft in opposite direction to take up slack on right side of chain. Force left side of chain out and measure difference between reference point and chain. If deflection exceeds .50", replace timing chain.

**Removal & Installation** — 1) Crank engine until timing marks are aligned (see illustration) and remove camshaft sprocket bolt and washer. Slide both sprockets and timing chain forward and remove as an assembly.

## 200" & 250" 6 CYLINDER (Cont.)

2) Install timing chain on sprockets with timing marks positioned properly (see illustration). Slide both sprockets and timing chain onto engine. Install camshaft sprocket bolt and washer. Tighten bolt and oil timing chain.

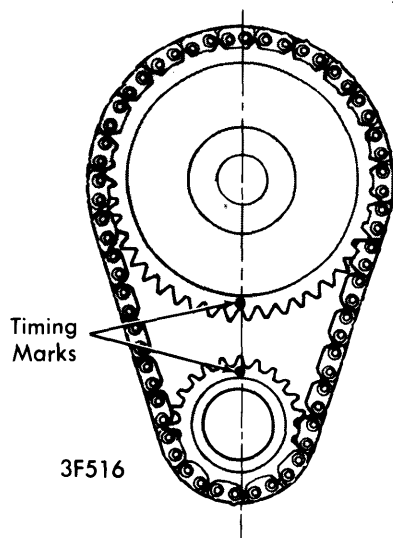

TIMING CHAIN SPROCKET ALIGNMENT

### CAMSHAFT

**Removal** - 1) Drain cooling system and crankcase. Remove radiator and grille. Remove condenser attaching bolts and position to one side. *NOTE* - Do not disconnect condenser refrigerant lines. Remove distributor, fuel pump and oil filter. Remove cylinder head and valve lifters.

2) Remove drive belt, fan, pulley and crankshaft damper. Remove front cover and timing chain. Remove oil dipstick, oil pan (250" only), oil pump and inlet tube. Remove camshaft thrust plate and carefully remove camshaft by pulling toward front of engine. *CAUTION* - Use care to avoid damaging camshaft journals and lobes upon removal.

**Installation** - Clean oil passage at rear of cylinder block, which feeds rocker arm shaft, by blowing compressed air into opening in block. Coat camshaft lobes with Lubriplate and journals with engine oil. Carefully slide camshaft through bearings and install thrust plate with oil groove toward rear of engine and tighten bolts. Replace front oil seal. Continue installation in reverse of removal procedure.

### CAMSHAFT BEARINGS

**Removal & Installation** - Remove engine from vehicle and remove flywheel. Remove camshaft and rear bearing bore plug. Using suitable driver-puller tool (T65L-6250-A), remove camshaft bearings. Position new bearings at bearing bores and press into place while noting the following: Oil holes in bearings must be aligned with oil holes in cylinder block. Front bearing must be installed below front face of cylinder block .030-.050". Rear bearing has two oil holes and must be installed 2 3/4" from face of camshaft thrust plate surface.

### CAMSHAFT END THRUST

With engine front cover removed, push camshaft toward rear of engine and install dial indicator so indicator point is on camshaft sprocket cap screw. Zero dial indicator. Position large screwdriver between camshaft sprocket and block. Pull camshaft forward and release it. If dial indicator reading is not within specifications, replace thrust plate.

### CAM LOBE LIFT

With rocker arm shaft removed, check lift of each lobe in consecutive order. Using a suitable dial indicator, position point on end of push rod and in same plane as push rod movement. Rotate crankshaft until lifter and push rod are at their lowest position and zero indicator. Rotate crankshaft slowly until push rod is in fully raised position. Check that total lift recorded with indicator is within specifications. If lift on any lobe is below specifications, camshaft and the valve lifters operating on worn lobe(s) must be replaced.

## ENGINE OILING

**Crankcase Capacity** - 4 quarts. Add 1 quart with filter change.

**Oil Filter** - Replace at first oil change, then every second oil change after.

**Normal Oil Pressure (Hot)** - 30-50 psi at 2000 RPM on 200" engines and 40-60 psi at 2000 RPM on 250" engines.

**Pressure Regulator Valve** - In pump body. Not adjustable.

### ENGINE OILING SYSTEM

**Rocker Arms, Push Rods & Valve Stems** - Oil from lower hole in rear camshaft bearing flows around grooved rear camshaft journal and out through upper hole in rear camshaft bearing through vertical passage in block and around left rear corner cylinder head bolt to oil port at rear rocker arm shaft bracket pad. Oil then flows around this bracket bolt to hollow rocker arm shaft and is distributed to each rocker arm for rocker arm, push rod and valve tip lubrication. Excess oil is discharged from rocker arm shaft at front shaft bracket. Oil from rocker chamber runs down push rods to lubricate push rod seat and lifter, then drains back into oil pan through cored openings in block.

**Timing Chain & Sprockets** - Lubricated by splash from oil pan.

**Oil Filter** - Full flow type mounted externally on left front corner of engine. Filter has integral bypass valve and anti-drain back diaphragm.

### OIL PUMP

**Removal & Disassembly** - Remove oil pan. Remove oil pump attaching bolts and pump from engine. Remove oil inlet tube, cover attaching screws and cover. Remove inner rotor and shaft assembly, and remove outer race. Drill a small hole and insert self-threading sheet metal screw into oil pressure relief valve chamber cap and pull cap from chamber. Remove spring and plunger.

**Inspection & Assembly** - Clean, inspect and oil all parts thoroughly (see specifications for clearances). Install outer race and inner rotor and shaft assembly. *NOTE* - Identification mark on rotor and on outer race both face to bottom of pump. Inner rotor and shaft, and the outer race are serviced as an assembly. Install cover and tighten cover bolts. Position a new

# Ford Motor Co. 6 Engines

## 200" & 250" 6 CYLINDER (Cont.)

### ENGINE OILING (Cont.)

gasket and oil inlet tube on oil pump and install attaching bolts. Prime oil pump by submerging inlet port in oil and rotate shaft until oil flows from outlet port.

#### Oil Pump Specifications

Shaft-to-Housing .....	.0015-.0030"
Rotor Assembly-to-Cover .....	.004" Max.
Outer Race-to-Housing .....	.001-.013"
Relief Valve Spring Tension	
200" .....	9.0-10.1 @ 1.078"
250" .....	20.6-22.6 @ 2.49"
Relief Valve-to-Bore .....	.0015-.0030"

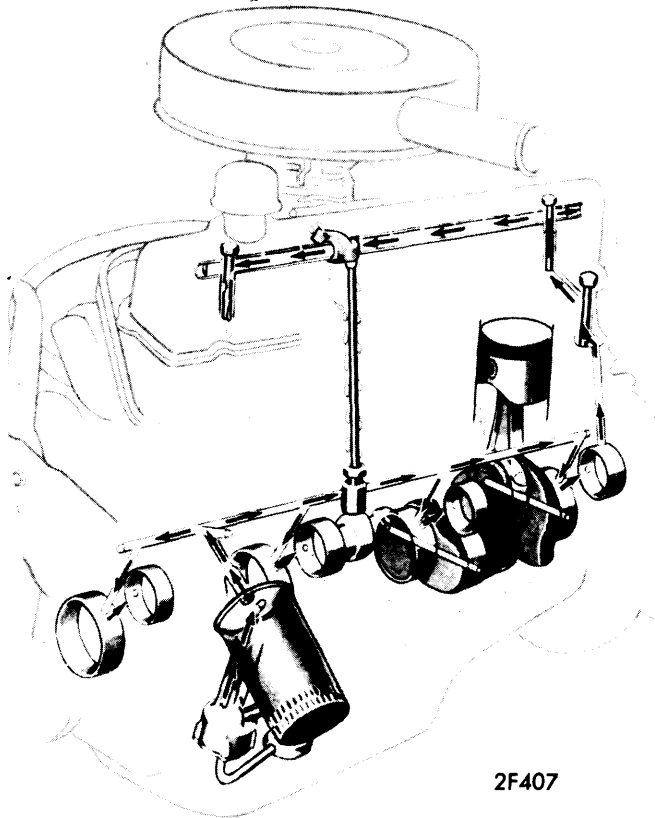

ENGINE OILING SYSTEM

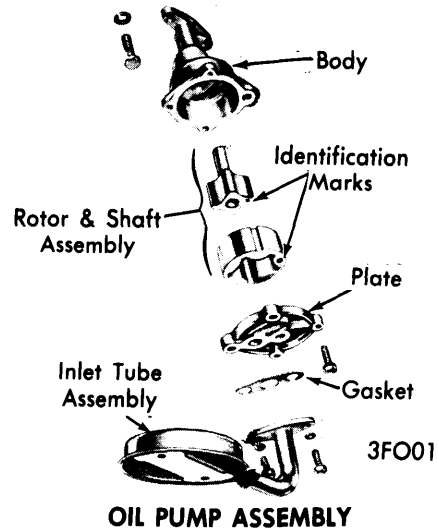

#### TIGHTENING SPECIFICATIONS

Application	Ft. Lbs.
Cylinder Head .....	⓪70-75
Exhaust Manifold.....	18-24
Oil Pan .....	7-9
Main Bearing Caps .....	60-70
Connecting Rod Caps.....	21-26
Vibration Damper.....	85-100
Camshaft Sprocket .....	35-45
Camshaft Thrust Plate.....	12-18
Flywheel .....	75-85
Rocker Shaft Support .....	30-35
Engine Front Cover.....	7-9
Water Outlet Housing.....	14-21
Pulley-to-Damper.....	35-50
Water Pump .....	12-15
Oil Pump.....	10-15

⓪ — Tighten cylinder head bolts in three steps as follows:  
 Step 1 — 55 ft. lbs. Step 2 — 65 ft. lbs. Step  
 3 — 70-75 ft. lbs.