

Propeller Shaft Alignment

OLDSMOBILE PROPELLER SHAFT ALIGNMENT

Oldsmobile, All Models

DESCRIPTION

Measurement of front and rear universal joints is accomplished by means of a suitable inclinometer (BT-6902). Readings must be made with car at curb height and with a full tank of gasoline. Jounce car up and down to assure curb height.

CHECKING & ADJUSTING

CHECKING

NOTE — In addition to suitable inclinometer (BT-6902), special wood block spacers must be installed between rear axle housing and frame. Blocks must rest solidly on axle housing, not on casting flash.

Wood Block Usage

Model	Wood Block No.
Omega	BT-7321
Cutlass	BT-6818
88 & 98 (Exc. 88 Wagon)	BT-6511-1
88 Wagon	BT-7204

Transmission Angle (All Models) — 1) Select and install correct wood block and use suitable hold-down clamp (BT-6511-17). Install upper hook through hole in frame and lower hook around shock unit on all models except Omega.

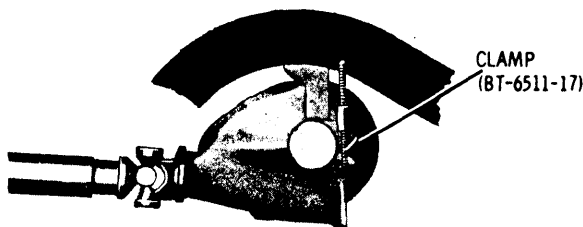

SPRING HOLD DOWN CLAMP

9F4507

2) On Omega models only, install upper hook over rubber bumper and lower hook under spring. On all models, adjust turnbuckles on clamps until wood blocks fit snugly between axle housing and frame.

3) Clean all dirt from exposed surfaces of universal joint bearings. On Omega only, remove retaining rings from bearings on Spicer equipped universal joints.

4) On Cutlass models, turn propeller shaft until slip yoke bearings are vertical. Install adapter (BT-7314) to bearing surface and center magnetic end of inclinometer (BT-6902) on bearing surface.

5) It may be necessary to rotate propeller shaft slightly to allow weight and cord to hang centered in slot at gauge end of tool. Turn knob of tool until weighted cord is at "O" marking of gauge.

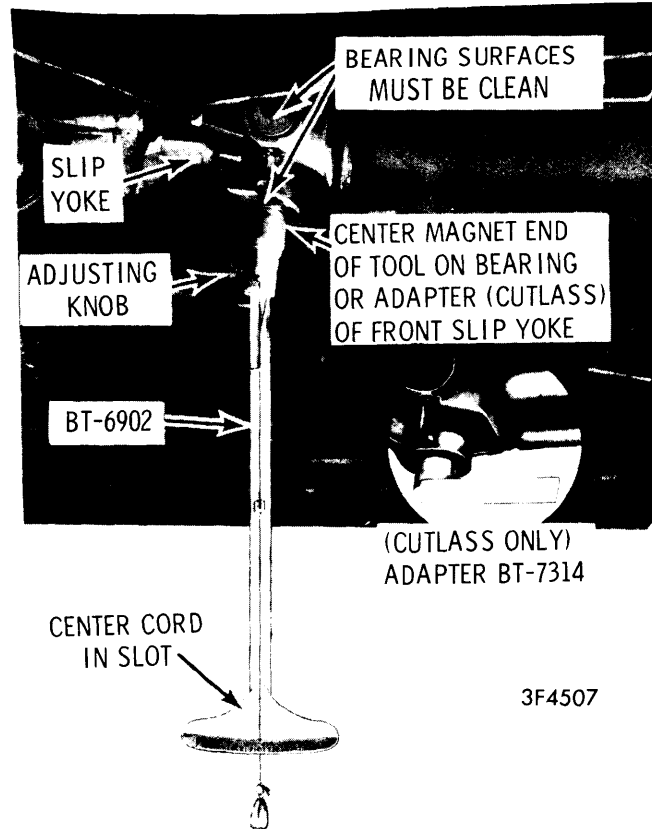

CHECKING TRANSMISSION ANGLE (TYPICAL)

6) Remove tool from bearing surface and rotate shaft 180°, then center tool on this bearing surface. Weighted cord should be at "O" marking without turning adjusting knob of tool. Remove tool.

CAUTION — Do not turn adjusting knob.

7) Rotate propeller shaft 90° until shaft yoke bearings are vertical. Center magnetic end of tool on bearing surface. Read gauge at cord position and record reading. See *Propeller Shaft Specifications* for correct transmission angles.

Differential Nose Angle (All Models) — 1) With wood blocks in position and retaining rings removed from Omega with Spicer equipped universal joints, clean exposed surfaces of universal joint bearings.

NOTE — Tool BT-6902 must be modified by filing a 1/4" x 1/16" deep notch in magnetic end for correct fitting of companion shaft yoke bearing on Omega Models.

2) Turn propeller shaft until companion bearings are vertical, center magnetic end of tool on bearing surface. Turn knob of tool until weighted cord is at "O" mark of gauge. Remove tool and rotate shaft 180°. Center tool on bearing surface. Weighted cord should be at "O" without turning adjusting knob. Remove tool.

CAUTION — Do not turn adjusting knob.

OLDSMOBILE PROPELLER SHAFT ALIGNMENT (Cont.)

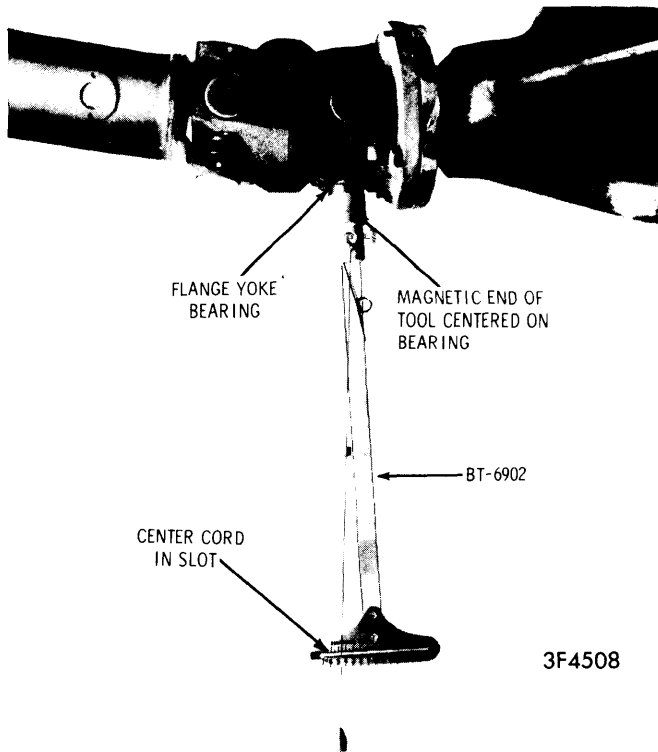

3F4508

CHECKING DIFFERENTIAL NOSE ANGLE (TYPICAL)

3) Rotate shaft 90° until propeller shaft yoke bearings are vertical. Center magnetic end of tool on bearing surface. Read gauge at cord position and record reading. See *Propeller Shaft Specifications* for correct differential nose angles.

ADJUSTMENT

Transmission Angle (All Models) – No provision is made for increasing transmission angle as transmission is mounted directly to crossmember support. To decrease transmission angle, add shims as necessary to obtain correct angle.

NOTE – Use care when installing shims to avoid contact between transmission and floor pan.

Differential Nose Angle (88 Wagon) – 1) Loosen and remove hold-down clamps and gauge blocks. Performing operation on one side at a time, support rear wheels or axle housing and place floor stands under frame, forward of front leaf spring attaching point. Loosen, but do not remove "U" bolt attaching nuts.

NOTE – "U" bolt threads must be wire brushed and oiled before loosening nuts. Loosen nuts three or four threads beyond bottom of "U" bolts.

2) Install proper degree shim between upper spring plate cushion and spring. Install shim from rear with thick end toward front of car. It may be necessary to bevel edges and apply silicone to shim for ease of installation.

3) Install spacers between upper and lower spring plates with thick end toward front of car. Torque "U" bolt nuts to 50 ft. lbs., remove stands, lower vehicle.

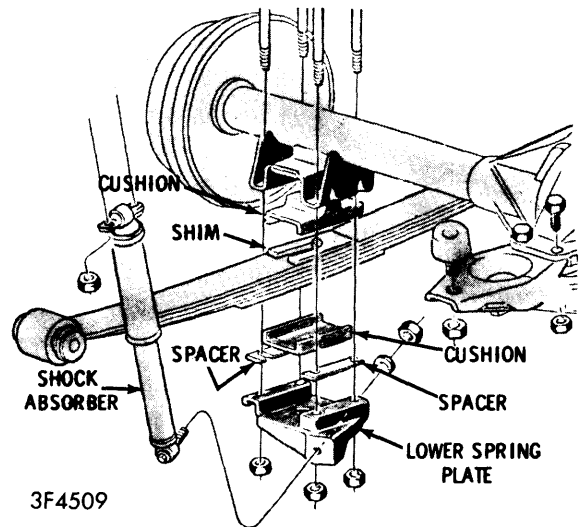

3F4509

SHIM & SPACER (88 WAGON)

Differential Nose Angle (Exc 88 Wagon) – To correct angle, upper control arms or bushings may need to be replaced. See *Oldsmobile Upper Control Arm in SUSPENSION Section*.

Propeller Shaft Specifications^①

Model	Transmission Angle	Differential Angle
Omega	1 1/4 °	4 °
Cutlass		
Except Sta. Wgn.	3 °	3 °
Sta. Wgn.	2 1/2 °	3 °
88		
Except Sta. Wgn.	3/4 °	10 3/4 °
Sta. Wgn.	3/4 °	2 ± 1 °
98	1/2 °	10 1/2 °

① – Angles are ± 1/4 ° except 88 Sta. Wgn. Differential Angle.