

Rear Axles

FORD MOTOR CO. INTEGRAL HOUSING (Cont.) (WER TYPE)

Axle Ratio Identification

Axle Ratio	Code	Ring Gear Diameter
3.07.....	WER-S,P,T	8.7"

REMOVAL & INSTALLATION

AXLE SHAFTS & BEARINGS

1) Raise vehicle on hoist. Remove wheels and brake drums. Remove carrier cover and drain lubricant. Working through differential case opening, loosen pinion shaft lock bolt and remove pinion shaft. Push axles toward center of axle housing and remove "C" locks. Remove axle shafts.

2) Remove oil seal and bearing from housing using suitable puller. Two types of wheel bearings are used: Bauer bearings, which have a loose fit in housing flange, and Torrington bearings, which have a snug press fit. To install, lightly coat bearing rollers with rear axle lubricant and install in axle housing, seating against shoulder. Install oil seal using suitable tool (T65F-1177-A). **CAUTION** — Seals are color coded: seals for right side are color coded with green stripes and the word "RIGHT" printed on it. Seals for left side are color coded yellow, and the word "LEFT" printed on them. If installed in wrong side, they will leak.

3) Replace "O" ring in "C" lock groove on axle shaft. Slide axle shaft into axle housing, taking care not to damage oil seal. Install "C" lock on inner end of axle shaft and pull shaft outward to seat shaft lock in counterbore of differential side gear. Position differential pinion gears and thrust washers 180° apart. Revolve gear assembly until holes in differential case are aligned with pinion gears, and install pinion shaft, aligning hole in shaft with lock bolt hole in case. Install lock bolt and tighten.

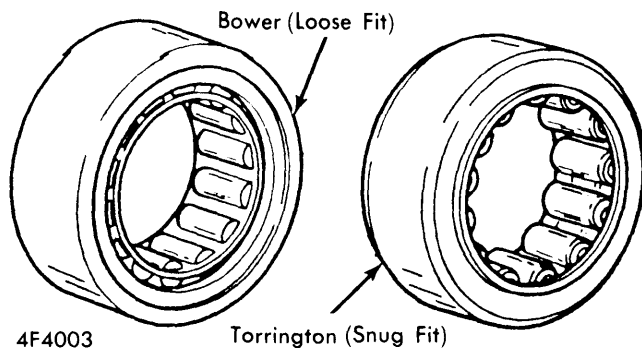

WHEEL BEARING ASSEMBLIES

REAR AXLE ASSEMBLY

Removal — Raise vehicle on hoist. Remove wheels, brake drums, axles, brake backing plates, and driveshaft. Disconnect lower end of shock absorbers at mounting brackets, track bar from axle housing stud, and vent hose. Supporting rear axle on jack, remove rear springs and insulators. Disconnect upper and lower suspension arms at axle housing, and lower axle out of vehicle.

Installation — Raise rear axle into position with floor jack. Connect lower suspension arms to mounting brackets on axle housing, but do not tighten mounting bolts. Position upper suspension arm in mounting bracket on axle housing, but do not tighten mounting bolt. Place rear coil springs and insulators into position in pockets. Install brake backing plates and axles. Raise rear axle on jack and connect track bar to mounting stud, install washer and nut and tighten. Connect shock absorbers.

Adjustment — Make sure both front and rear pivot bolts of upper and two lower suspension arms are loose, then raise axle assembly to controlled height (see illustration). Hold axle at controlled height by placing blocks or pieces of steel pipe between axle housing and bumper rear screw on side rail. With axle at controlled height, tighten suspension upper and lower arm front pivot bolts and nuts. Tighten lower arm to axle housing pivot bolts and nuts.

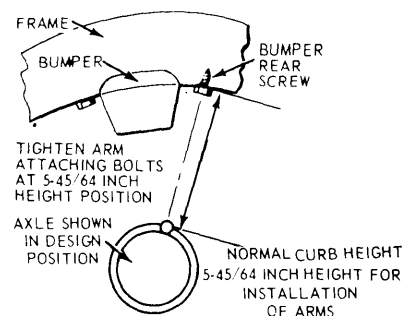

4F002

AXLE NORMAL CURB HEIGHT & CONTROLLED HEIGHT FOR ARM INSTALLATION

PINION FLANGE & OIL SEAL

Raise vehicle on hoist and make scribe marks on propeller shaft universal joint, drive pinion flange, and end of pinion stem. Remove driveshaft, rear wheels, and brake drums. Using an INCH lb. torque wrench on pinion nut, measure pinion bearing preload through several revolutions of pinion flange. Using suitable holding tool, hold flange and remove pinion nut and washer. Using suitable pullers, remove pinion flange and drive pinion oil seal. Inspect flange for damage, repair as necessary. Using suitable tool, install drive pinion oil seal. Install flange, washer and nut, then tighten, taking frequent

FORD MOTOR CO. INTEGRAL HOUSING (Cont.) (WER TYPE)

preload readings until preload is at original setting. **CAUTION** — Under no circumstances should pinion nut be backed off to lessen preload. If this is done, a new pinion bearing spacer must be installed and nut retightened until proper preload is obtained. In addition, universal joint flange must never be hammered on, or power tools used.

OVERHAUL

DIFFERENTIAL CASE & DRIVE PINION

Removal — Remove carrier cover and drain lubricant. Remove axle shafts, driveshaft, and differential bearing nut locks. Install dial indicator and record backlash and ring gear runout. Marking caps and case for reassembly, remove bearing caps, cups, adjusting nuts, and case assembly. Using suitable holding tool, hold pinion flange and remove nut and washer. Remove flange. Drive pinion out of front bearing cone and remove from carrier housing. Remove and discard bearing spacer and pinion shaft oil seal.

Disassembly — Using suitable press, remove rear bearing from pinion shaft, then measure and record thickness of pinion locating shim, located under rear bearing. Remove differential side bearings using suitable puller. Marking ring gear and case for reassembly, remove ring gear attaching bolts, and using a soft-faced hammer, tap ring gear from case. Do not remove pinion bearing cups from carrier casting unless cups are worn or damaged, or unless pinion bearings are to be replaced. If cups are to be replaced, remove with brass drift.

Inspection — Clean all parts thoroughly in suitable cleaning solvent. When replacing ring gear and pinion, note original factory shim is correct thickness to adjust for variations in both carrier casting and original gear set dimension. To select correct shim thickness for new gear set, note following: Using micrometer, measure thickness of original shim removed from axle, and use same thickness in assembly of replacement carrier assembly or drive pinion. If further shim change is necessary, it will be noted in a tooth pattern check. If original shim is lost, use a nominal shim (.030") and make a tooth pattern check. **CAUTION** — Ring gear and pinion are installed as a matched set. Be sure same identifying number (painted in white) appears on ring gear and pinion head.

Reassembly — Lubricate all parts with rear axle lubricant. Place ring gear on differential case. Clean and dry bolts thoroughly and apply a small amount of Loctite to threads. Install bolts and tighten. Using suitable press, install differential bearings onto case. Install pinion shaft lock bolt loosely into case. Install shim and pinion bearing rear cone on shaft and press firmly against pinion shaft shoulder.

Installation — 1) Place new pinion bearing preload spacer on pinion shaft. Lubricate pinion bearings and install front bearing cone in housing, followed by pinion oil seal. Insert drive pinion flange into seal and hold firmly against front bearing cone. From rear of carrier, insert pinion shaft through flange. Install washer and pinion nut and gradually tighten to

remove end play. Continue to tighten nut, checking preload often. Rotate pinion several revolutions after each tightening step.

2) Apply a thin coat of lubricant on bearing bores so differential bearing cups will move easily. Place cups on differential bearings, and set case in carrier housing. **NOTE** — Be sure to align timing marks on ring gear and pinion, if so equipped. Slide case assembly along bores until a slight backlash is felt between gears. While holding case in place, set adjusting nuts in bores so that they just make contact with bearing cups. Position bearing caps on pedestals, install and tighten bolts, and turning adjusting nuts to insure they are free. Tighten bolts to 40-55 ft. lbs. to be sure cups and adjusting nuts are seated, then loosen bolts and retighten to 5 ft. lbs. and make backlash and side bearing preload adjustments.

BACKLASH & SIDE BEARING PRELOAD

NOTE — Left adjusting nut is on ring gear side of carrier, right nut is on pinion side.

1) Loosen right nut until it is away from bearing cup. Tighten left nut until ring gear is just forced into pinion with no backlash, then rotate pinion to insure there is no binding. Recheck right nut at this time to make sure it is still loose. **NOTE** — Tightening left nut moves ring gear into pinion to decrease backlash, tightening right nut moves ring gear away.

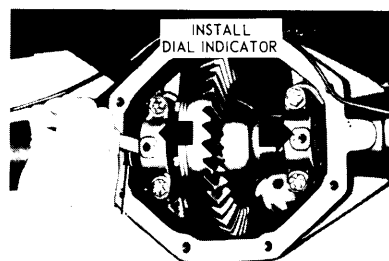

2F5006

BACKLASH & BEARING PRELOAD ADJUSTMENT

2) Install a dial indicator as shown in illustration. Tighten right nut until it first contacts bearing cup, then preload bearings from .008-.012" case spread. Rotate pinion gear several times in each direction to seat bearings. Tighten differential bearing cap bolts.

3) Measure backlash at several teeth around ring gear. If backlash is not within specification, loosen one nut and tighten opposite nut an equal amount, to move ring gear away from or toward pinion gear. **NOTE** — When moving adjusting nuts, final movement should always be in a tightening direction. Recheck differential bearing preload, then make a gear tooth pattern check to insure correct assembly.

Rear Axles

FORD MOTOR CO. INTEGRAL HOUSING (Cont.) (WER TYPE)

ADJUSTMENT SPECIFICATIONS

Application	Inches
Ring Gear Backface Runout.....	.003
Side Gear Thrust Washer Thickness.....	.030-.032
Pinion Gear Thrust Washer Thickness.....	.030-.032
Differential Bearing Preload	
New Bearings.....	.008-.012
Used Bearings.....	.006-.010
Nominal Pinion Shim Thickness.....	.030
Ring Gear to Pinion Backlash.....	.008-.012
Maximum Backlash Variation.....	.003

TIGHTENING SPECIFICATIONS

Application	Ft. Lbs.
Bearing Cap Bolt.....	70-85
Bearing Adjusting Nut Lock Bolt.....	12-25
Ring Gear Attaching Bolts.....	70-85
Minimum Torque (Pinion Nut) For	
Pinion Bearing Preload.....	①140
Pinion Bearing Preload (Collapsible Spacer)	
Original Bearings.....	②8-14 INCH lbs.
New Bearings.....	②17-27 INCH lbs.
① — If preload exceeds specification before this torque is obtained, install a new spacer.	
② — With oil seal.	