

CHRYSLER CORP. (7 1/4" RING GEAR) (Cont.)

PINION FLANGE & OIL SEAL

Raise vehicle on hoist and make scribe marks on propeller shaft universal joint, drive pinion flange and end of pinion stem. Disconnect propeller shaft and secure in upright position. Remove wheels and brake drums to prevent any drag. Measure pinion bearing preload by rotating pinion with torque wrench through several revolutions and record. Using suitable tool (C-3281), hold companion flange and remove drive pinion nut and Belleville washer. Remove flange. Lower rear of vehicle to prevent lubricant leakage. Remove pinion oil seal. Inspect flange for damage, repair as necessary. Using suitable tool (C-4002), install new pinion oil seal. Seal is properly installed when seal flange contacts housing flange face (outside diameter of seal is pre-coated with a special sealer so no sealing compound is required). Position flange on pinion stem, being careful to match scribe marks. Install Belleville washer (convex side of washer out) and pinion nut, then tighten. Rotate pinion several revolutions to assure that bearing rollers are properly seated. Using a torque wrench, measure pinion bearing preload, continue tightening pinion nut and preload until preload is at original setting. Under no circumstances should preload be more than 10 INCH lbs. over original setting. **CAUTION** — Under no circumstances should the pinion nut be backed off to lessen preload. If desired preload is exceeded, a new collapsible spacer must be installed and nut retightened until proper preload is obtained. In addition, the universal joint flange must never be hammered on, or power tools used.

SPECIFICATIONS

Application	Clearance or Torque
Ring Gear & Pinion Backlash.....	① .004"-.006"
Pinion Bearing Drag Torque	② 15-25 INCH lbs.
Ring Gear & Case Runout005" (Max.)
Differential Bearing Cap Bolts	40 ft. lbs.
Ring Gear-to-Case Bolts (L/H Thread)	55 ft. lbs.
Drive Pinion Flange Nut	210 ft. lbs. (Min.)
Carrier Cover Bolts.....	20 ft. lbs.
Axle Shaft Retainer Nuts.....	35 ft. lbs.
Propeller Shaft Bolts (Rear).....	15 ft. lbs.
Spring Clip ("U" Bolt) Nuts.....	40 ft. lbs. (Max.)
Wheel Stud Nuts	55 ft. lbs.
Shock Absorber Stud Nuts (Lower).....	50 ft. lbs.

- ① — At point of minimum backlash.
 ② — Turning torque.

OVERHAUL

DIFFERENTIAL

Disassemble — **NOTE** — Side play and runout checks taken during disassembly will be useful during reassembly.

1) Drain fluid from housing, then remove cover and clean interior of differential. Position a screwdriver between left side of axle housing and differential case flange. Using a prying motion, determine if side play is present. **NOTE** — There should be no side play. Using a dial indicator mounted to housing, measure drive gear runout by turning drive gear several complete revolutions. Mark drive gear and differential case at point of maximum runout. **NOTE** — If runout exceeds .005", differential case may be damaged.

2) Remove drive pinion nut and washer. Using a suitable tool (C-452 & C-3281) remove drive pinion flange, and remove drive pinion oil seal. Mark axle housing and differential bearing caps for relocation. Remove adjuster lock from each bearing cap and loosen bolts, but do not remove bearing caps. Insert suitable tool (C-4164) through axle tube on each side and loosen hex adjuster. Remove bearing caps, adjusters and differential assembly using extreme caution. **NOTE** — Differential bearing caps must be kept with their respective bearing cones.

3) **NOTE** — To remove drive pinion or front pinion bearing cone, pinion stem must be driven rearward out of bearing. This will damage bearing rollers and cup, so new cone and cup assembly must be replaced. Discard collapsible spacer. Using brass drift and hammer, remove front and rear bearing cups from housing. Using suitable tool (C293-P) and adapters (C-293-40), remove rear pinion bearing cone from drive pinion stem. Remove shim from drive pinion stem and record thickness.

Inspection — Clean all parts except axle shaft bearings in a suitable solvent. Check all parts for wear or damage, replace as necessary. **NOTE** — If axle shaft bearings, collars, and retainers are removed from shaft, they must be replaced.

Reassemble — Lubricate all parts when assembling and adjusting. Install thrust washers on differential side gears and position gears in case. Place thrust washers on both differential pinion gears and mesh pinion gears with side gears, having pinion gears exactly 180° apart. Rotate side gears to align pinion gears and washers with pinion shaft hole in case. Install lock pin in case from drive gear tooth side. Using suitable stone, relieve sharp edge of chamfer on inside diameter of ring gear. Heat ring gear with heat lamp or immersing gear in hot water or oil. Temperature should not exceed 300°F. **NOTE** — Do not use a torch. Using pilot studs to align gear to case, install new drive gear bolts through case flange and into drive gear. Place unit on soft jawed vise and alternately tighten bolts. Using arbor press and suitable tool (C-3716-A), install differential bearing cones. **CAUTION** — Do not exert pressure against bearing cage as damage will result.

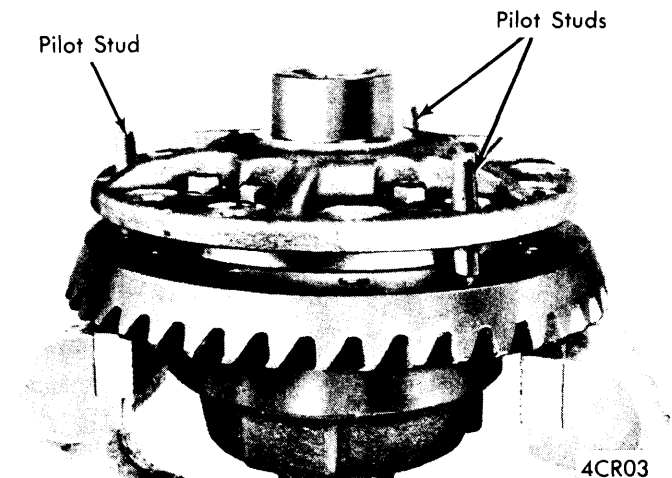

USING PILOT STUDS TO LOCATE CASE TO HEATED RING GEAR

CHRYSLER CORP. (7 1/4" RING GEAR) (Cont.)

Pinion Bearing Cup Installation – Pinion gauge tool set C-3715 is used to install drive pinion bearing cups as well as to determine pinion depth of mesh. Start both drive pinion bearing cups into axle housing. Place rear spacer (SP-3244) on tool and place front pinion bearing cone on centralizing sleeve, followed by tool sleeve, centralizing washer and nut. While holding compression sleeve from turning, tighten nut drawing pinion bearing cups into axle housing cup bores. Permit tool to turn several revolutions during tightening operation to permit bearing rollers to align. Leave tool in carrier for determining depth of mesh.

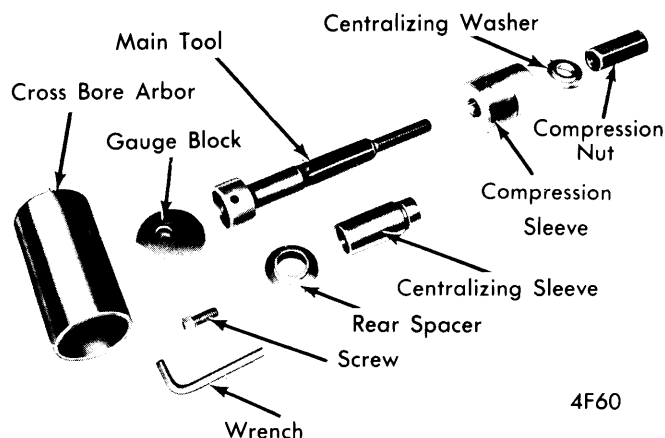

PINION GAUGE TOOL SET C-3715

Pinion Setting (With Tool C-3715) – With main tool left in housing after installing drive pinion bearing cups, loosen tool nut and retighten to 15-25 INCH lbs. of turning torque. Attach gauge block to main tool using Allen screw. Position cross bore arbor in axle housing differential bearing seats and install bearing caps. Tighten cap bolts lightly. Select rear pinion bearing mounting shim which will fit between cross bore arbor and gauge block, fit must be snug but not tight. If mark on pinion head is plus (+), select a shim that many thousandths thinner for installation. If mark on pinion has a minus (-), select a shim that many thousandths thicker for installation. Treat other pinion markings in a similar manner. Spacers are available in .001" increments from .020" to .038".

Pinion Installation & Bearing Preload – *NOTE* – Pinion bearing mounting shims are chamfered on one side and must be installed on pinion stem with chamfered side toward pinion head.

1) Place shim and rear bearing cone on pinion stem and using suitable tool (C-3717), press bearing on pinion stem. Lubricate bearing cones with rear axle lubricant and insert drive pinion and bearing assembly up through axle casting. Install collapsible spacer followed by front bearing cone on pinion stem. Install companion flange using suitable tool (C-3718). *NOTE* – Use care not to collapse spacer during installation. Remove tool and flange.

2) Install drive pinion oil seal using suitable tool (C-4002) until seal flange contacts housing flange face. Support pinion in carrier, reinstall companion flange.

3) Remove tools and install Belleville washer (convex side up) and pinion nut. Hold companion flange with suitable tool (C-3281) and tighten nut until no end play can be detected. Continue tightening nut and checking preload with an INCH lb. torque wrench until pinion bearing preload is 15-30 INCH lbs. Final nut torque must be above 210 ft. lbs. *NOTE* – If desired preload is exceeded, a new spacer must be installed and nut retightened until proper preload is obtained.

Differential Bearing Preload & Ring & Pinion Backlash Adjustment – 1) Set pinion bearing preload in normal manner then install differential assembly with bearing caps and adjusters. On 7 1/4" axles, be sure that adjusters are turned outboard as far as possible. Differential bearings and adjuster threads must be liberally lubricated with axle oil.

2) Check alignment of adjuster threads then tighten top cap screws on right and left sides to 10 ft. lbs. Tighten bottom cap screws finger tight until head is just seated on bearing cap. Using Tool C-4164 (or equivalent), check each adjuster to make sure that it rotates freely, then turn both adjusters in until bearing freeplay is eliminated with some drive gear backlash (approximately .010"), existing between drive gear and pinion.

3) Seat bearing rollers. *NOTE* – To assure accurate adjustment changes and to maintain gear mesh index, bearings must be seated by turning drive pinion one half turn in each direction five to ten times, each time adjuster is moved.

4) Install dial indicator and find point of minimum backlash checking at four positions approximately 90° intervals around drive gear. Rotate gear to position with least backlash and mark index so that all backlash readings will be taken with same teeth mesh. *NOTE* – Permissible backlash variation is .003".

5) Loosen right adjuster and tighten left adjuster until backlash is .003-.004", with each adjuster tightened to 10 ft. lbs. Seat bearing rollers and tighten bearing cap screws to 45 ft. lbs.

6) Tighten right adjuster to 70 ft. lbs. and seat rollers at same time until torque remains constant at 70 ft. lbs. *NOTE* – Maintain specified adjuster torque to obtain accurate backlash and preload settings. Backlash should be .004-.006". If backlash does not meet specifications, increase torque on right adjuster and seat rollers until correct backlash is obtained.

7) Tighten left adjuster to 70 ft. lbs. and seat bearings at same time until torque remains constant.

8) Install adjuster locks and torque lock screws to 90 inch lbs.