

## 500" CADILLAC V8

### GENERAL SPECIFICATIONS

Engine	Net HP At RPM	Torque (Ft. Lbs. at RPM)	Compr. Ratio	Bore	Stroke	Displ. Cu. Ins.
500"	190 @ 3600	360 @ 2000	8.5-1	4.300"	4.304"	500

**NOTE** — Horsepower and Torque figures given above are NET. Net Horsepower and Torque represents power at the flywheel when the engine is installed in a vehicle, with wide open throttle and all systems operating such as; air cleaner, exhaust system, water pump, generator, oil pump and air conditioning.

### ENGINE IDENTIFICATION

**Vehicle Identification Number** — Located on forward lower edge of windshield trim molding on drivers side of car and visible from outside of car. The number is decoded as follows:

**6C47S5Q100001**

**First Digit** — Indicates Cadillac Division.

**Second Digit** — Car Line Series.

**Third & Fourth Digits** — Body Type.

**Fifth Digit** — Engine Designation. (R-472") & (S-500").

**Sixth Digit** — Model Year.

**Seventh Digit** — Plant Designation.

**Remaining Digits** — Sequence Built Number.

**Engine Numbers** — Two numbers are stamped on engine block, one number is an engine unit number and is located behind left cylinder head. The other is a V.I.N. derivative number and is located behind intake manifold and is decoded as follows:

**65Q100001**

**First Digit** — Indicates Cadillac Division.

**Second Digit** — Model Year.

**Third Digit** — Plant Designation.

**Remaining Digits** — Sequence Built Number.

### SPECIAL ENGINE MARKS

Letters stamped in groups of two located on cylinder head gasket surface midway between cylinders denote cylinder and piston sizes. Identification is obtained as shown in following table:

Letter	Cyl. Size	Piston Size
A	4.3000-4.3002"	4.2992-4.2994"
B	4.3002-4.3004"	4.2994-4.2996"
C	4.3004-4.3006"	4.2996-4.2998"
D	4.3006-4.3008"	4.2998-4.3000"
E	4.3008-4.3010"	4.3000-4.3002"
H	4.3010-4.3012"	4.3002-4.3004"
J	4.3012-4.3014"	4.3004-4.3006"
K	4.3014-4.3016"	4.3006-4.3008"
L	4.3016-4.3018"	4.3008-4.3010"
M	4.3018-4.3020"	4.3010-4.3012"

### ENGINE REMOVAL

See Engine Removal at end of ENGINE Section.

### INTAKE MANIFOLD

**Removal** — 1) Disconnect negative battery cable and remove air cleaner and heat tube. Disconnect carburetor linkage, all coil wires (HEI connector if equipped), anti-dieseling solenoid, downshift switch wires and temperature

sending unit wire. Remove distributor cap, ignition coil, anti-dieseling solenoid and bracket.

2) Disconnect all vacuum lines to carburetor and manifold, fuel line at carburetor, and PCV valve at right rocker arm cover. Disconnect A/C wiring and mounts, then position compressor to one side (with hoses connected). Remove nuts and bolts securing intake manifold and remove manifold. Remove sheet metal manifold shield and gasket, then remove front and rear manifold to block gaskets.

**Installation** — Position rubber seals over rails at front and rear of cylinder block. Tabs on gasket should be positioned in holes in rails and beveled ends of gasket tucked into slot at mating of head and rail. Use suitable sealer and position sheet metal gasket and shield on engine. **NOTE** — Holes in gasket should engage dowel pins on cylinder heads. Install manifold and tighten nuts and bolts.

### CYLINDER HEAD

**Removal** — Drain cooling system and remove intake and exhaust manifolds. Disconnect electrical and ground connections from heads. Remove power steering pump and position to one side. Remove alternator and A.I.R. pump. Remove rocker arm covers, rocker arm assemblies (must be installed in original positions) and push rods. Remove cylinder head bolts and lift heads from block.

**Installation** — Clean all gasket surfaces and position cylinder head and gasket over dowels on block. Install ten head bolts in locations as shown in illustration and table. Tighten head bolts, starting from center of head and working toward both ends.

Bolt Location	Length
A (Bolt)	4.36" (Medium)
B (Bolt)	4.77" (Long)
C (Bolt)	3.02" (Short)
D (Bolt/stud)	4.77" (Long)

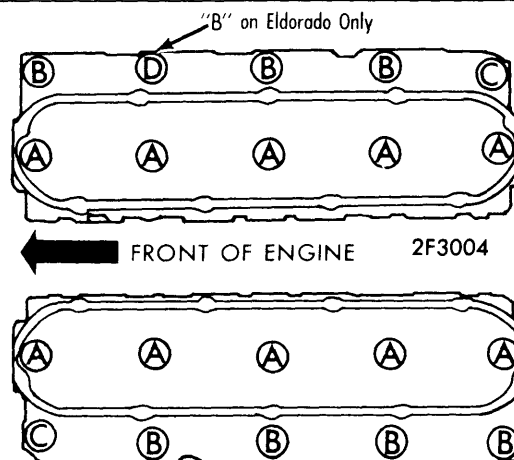

CYLINDER HEAD BOLT LOCATION

# General Motors V8 Engines

## 500" CADILLAC V8 (Cont.)

VALVES							
Engine & Valve	Head Diam.	Face Angle	Seat Angle	Seat Width	Stem Diameter	Stem Clearance	Valve Lift
500" Int. Exh.	2.000"	44°	45°	1/16"	.3413-.3420"	.001-.0027"	.457"
	1.625"	44°	45°	1/16"	.3413-.3420"	.001-.0027"	.473"

### VALVE ARRANGEMENT

E-I-E-I-E-I-E-I (Right bank front to rear).  
I-E-I-E-I-E-I-E (Left bank front to rear).

### VALVE GUIDE SERVICING

If stem-to-guide clearance exceeds specifications, valve guide should be reamed to next oversize and valve with corresponding oversize stem installed. Service valves are available in standard .003", .006", and .013" oversize. Use suitable reamers to obtain correct clearance. **NOTE** - Valve guides and valves .003" oversized may be installed at factory and indicated by a "3" stamped on cylinder head gasket surface in line with oversize valve. Oversize valves are marked on valve head.

### VALVE STEM SEALS

A nylon oil shedder is used which is part of valve spring retainer (see illustration). Replace any time valve spring is removed.

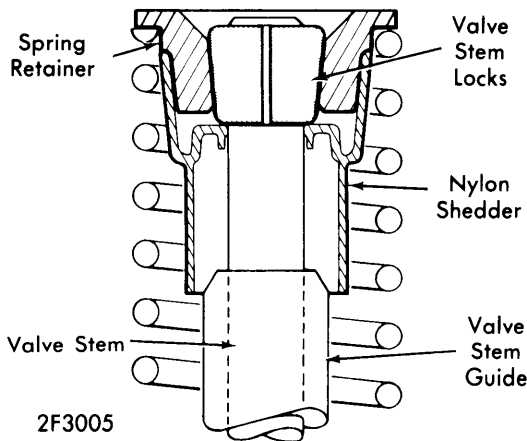

### VALVE SPRING RETAINER & OIL SHEDDER

VALVE SPRINGS			
Engine	Free Length	PRESSURE (LBS.)	
		Valve Closed	Valve Open
500" Int. & Exh.	2.250"	60-65 @ 1.946"	155-165 @ 1.496"

### VALVE SPRINGS

**Removal** - Remove air cleaner, rocker arm cover, rocker arm assembly, push rods and spark plug on cylinder to be serviced. Install suitable adapter (J-22794) to spark plug port and supply air to cylinder. Install rocker arm support bolt and position

suitable valve spring compressor (J-22765) over bolt. Compress valve spring, remove locks from valve stem and lift out spring retainer with nylon shedder, then remove spring.

**Installation** - Install valve spring and new retainer with nylon shedder. Use suitable valve spring compressor to compress spring and install locks.

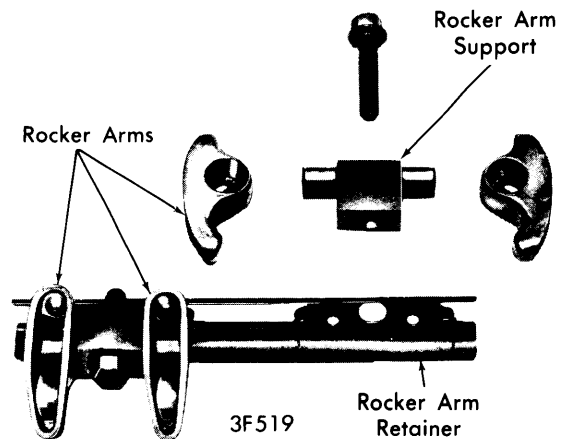

### ROCKER ARM ASSEMBLY

#### ROCKER ARM ASSEMBLY

Ensure that all parts are replaced in original order (see illustration).

#### HYDRAULIC VALVE LIFTER ASSEMBLY

Valve plungers and bodies are matched sets and parts are not interchangeable. Replace any lifter found to be defective.

#### HYDRAULIC VALVE LIFTER LEAKDOWN RATE CHECK

Use suitable leakdown rate tester (J-3074) to check for faulty lifters without disassembling engine. Tool uses a feeler gauge between rocker arm and valve stem which causes valve spring pressure to force oil out of lifters. When lifter has leaked down enough for valve to seat, a spring on tool which is compressed against valve spring retainer, ejects feeler gauge. Noisy lifter(s) will be those which have shortest leakdown rate. Run engine to allow lifters to fill up with oil and check lifters in following order: **NOTE** - Insert feeler gauge of tool quickly to avoid unnecessary leakdown.

1) With rotor at No. 1 firing position, check:

- No. 1 Intake
- No. 2 Intake
- No. 5 Intake
- No. 7 Intake
- No. 8 Intake
- No. 1 Exhaust
- No. 3 Exhaust
- No. 5 Exhaust
- No. 6 Exhaust
- No. 8 Exhaust

2) With rotor at No. 4 firing position, check:

- No. 3 Intake
- No. 4 Intake
- No. 6 Intake
- No. 2 Exhaust
- No. 4 Exhaust
- No. 7 Exhaust

## 500" CADILLAC V8 (Cont.)

PISTONS, PINS, RINGS						
Engine	PISTONS	PINS		RINGS		
	① Clearance	Piston Fit	Rod Fit	Ring	End Gap	Side Clearance
500"	.0006-.0010"	.0002-.0004"	Press Fit	Comp. Oil	.013-.025" .015-.055"	.0017-.0040" None

① Piston measured at top of skirt.

### OIL PAN

See *Oil Pan Removal at end of ENGINE Section.*

### PISTON & ROD ASSEMBLY

**Removal** — With cylinder heads, oil pan and oil pickup tube assembly removed, use a suitable ridge reamer to remove any ridge or deposits on upper end of cylinder bore. **NOTE** — *Piston must be at bottom of stroke and covered with cloth to collect cuttings.* Remove rod cap and install suitable tool on connecting rod studs to protect crankshaft. Push piston and rod assembly out top of cylinder block.

**Installation** — Lightly coat pistons, rings and cylinder walls with engine oil. Ensure compression rings are installed with dimple on ring facing top of piston. Install suitable ring compressor on piston and connecting rod stud guides. Install piston and rod assembly in cylinder bore with notch on top of piston towards front of engine (letter "R" on piston toward rear). Guide connecting rod onto crankshaft journal while tapping piston head with hammer handle to seat connecting rod against crankshaft. Remove tool from connecting rod studs and install mating rod cap ensuring that numbered side of cap is on same side as numbered side of rod. **NOTE** — *Numbered sides of connecting rods on Nos. 1,3,5,7 rods must be on right side of engine and Nos. 2,4,6,8 on left side of engine.* Install rod cap nuts and tighten.

### FITTING PISTONS

Measure pistons  $\frac{3}{16}$ " below upper cross slot or  $\frac{1}{4}$ " below oil ring groove. Measure cylinders  $1\frac{1}{8}$ " from top of bore, crosswise to cylinder block.

### PISTON PINS

**Removal** — Using suitable tool (J-8390), position piston and connecting rod assembly on support with side of piston marked with "R" upward. Press pin from assembly. **NOTE** — *Keep pins in order so they may be installed in piston from which they were removed.*

**Installation** — Lubricate piston pin and pin holes in piston with engine oil. Position connecting rod in its respective piston so when assembly installed in engine, side of piston stamped with "R" is toward rear of engine and number on lower end of rod is down. Press pin until it bottoms on spacer in support (see illustration).

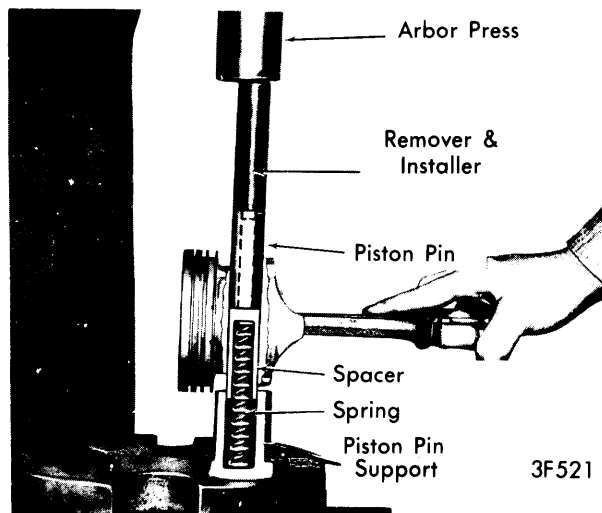

PISTON PIN INSTALLATION

## CRANKSHAFT MAIN & CONNECTING ROD BEARINGS

Engine	MAIN BEARINGS			CONNECTING ROD BEARINGS			
	Journal Diam.	Clearance	Thrust Bearing	Crankshaft End Play	Journal Diam.	Clearance	Side Play
500"	3.250"	②.0001-.0026"	No. 3	③.002-.012"	2.500"	④.0005-.0028"	.008-.020"

① — Total, 2 Rods.

③ — Wear limit .015"

② — Wear limit .0045"

④ — Wear limit .0035"

### MAIN & CONNECTING ROD BEARINGS

**NOTE** — *Following procedures are performed with oil pan and oil pickup tube assembly removed.*

**Connecting Rod Bearings** — After ensuring rod caps are marked for cylinder identification, remove rod caps. Use

Plastigage method for checking proper bearing clearances. If clearance is not within specifications, replace bearings. If new bearings (standard bearings only size available) do not bring clearances within specifications, crankshaft must be replaced. **NOTE** — *When installing bearings, tangs on bearings must match notches in rod and cap.*

## 500" CADILLAC V8 (Cont.)

**Main Bearings** — 1) Check main bearing clearances one at a time using Plastigage method. If bearings are being checked with engine in vehicle, crankshaft must be supported to take up clearance between upper bearing half and crankshaft (place strip of .005" brass shim stock between lower bearing half and crankshaft bearing journal in bearing caps adjacent to bearing being checked). If clearance is not within specifications, replace bearings. If new bearings (standard bearings only size available) do not bring clearances within specifications, crankshaft must be replaced.

2) No. 1 upper and lower bearings are interchangeable and No. 2 and 4 upper bearings are interchangeable. No. 2 and 4 lower bearings are interchangeable. No. 3 and 5 bearings are not interchangeable and must be reinstalled in original positions.

3) To change main bearing upper halves, insert suitable tool in oil hole of crankshaft journal and rotate crankshaft clockwise to roll bearing from engine. Oil new upper bearing and with locating tang in correct position, rotate crankshaft counterclockwise to position bearing (with suitable tool in oil hole). **CAUTION** — Main bearing caps must be installed in same position they were removed from and facing same direction.

**THRUST BEARING ALIGNMENT**

With all main bearing cap bolts finger tight, tap crankshaft forward, then rearward several times to align (No. 3) thrust bearings. Tighten all main bearing cap bolts.

**REAR MAIN BEARING OIL SEAL**

**Removal** — Remove engine oil pan. Remove rear main bearing cap and discard lower seal half removed from bearing cap. Rotate upper seal half by pushing on one end with sharp object and remove seal half from cylinder block. Inspect grooves in bearing cap and cylinder block to ensure they are clean, dry and free from burrs.

**Installation** — 1) **NOTE** — Two seal halves are identical and pre-lubricated with a film of wax for break-in. Do not remove or damage this film. To install lower half of seal in bearing cap, slide end of seal into position at one end of cap and place suitable tool (see illustration) made from shim stock in groove at other end of bearing cap. Lip of seal must face front of engine. Install seal half using tool as a "shoehorn" ensuring seal is flush on each side.

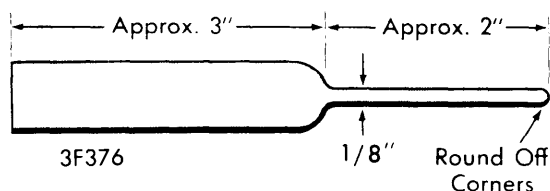
**OIL SEAL INSTALLING TOOL**

2) To install upper half of seal in cylinder block, position tool in groove of block. Lubricate seal with Lubriplate and start into groove in block with lip facing forward. Rotate seal into position using care not to distort it. Ensure that seal ends are flush at split line, install main bearing cap and tighten cap bolts.

**ENGINE FRONT COVER**

**Removal** — **NOTE** — On Eldorado models, engine must be removed from vehicle. Remove crankshaft pulley and spacer. Loosen starter enough to gain access to oil pan bolts. Loosen oil pan bolts and lower front of oil pan. Remove lower

radiator hose from water pump. Remove bolts securing front cover and lift off front cover and water pump as an assembly.

**Installation** — Clean all gasket surfaces and install new front cover gasket over locating dowels on cylinder block using a small amount of suitable sealer to hold gasket in place. Install front cover and water pump assembly over end of crankshaft, lining up dowel holes in cover with dowels on cylinder block. Install bolts and tighten (see illustration and table for location of bolts and specifications).

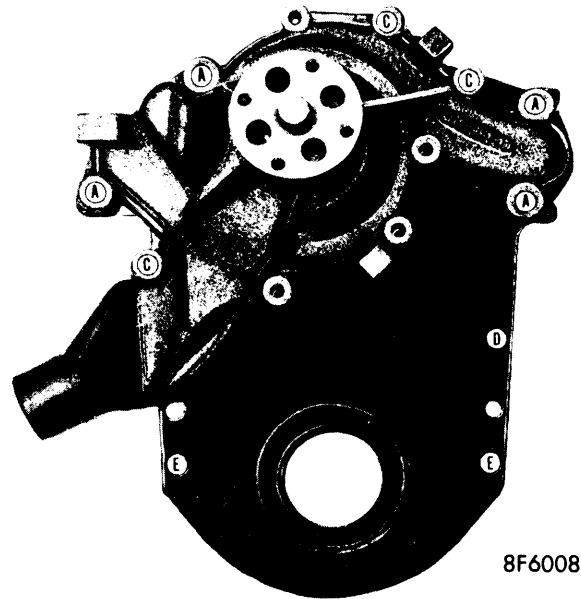

Key	(No.)	Size	Torque
A	(4)	3/8-16 x 1-3/8	22 Foot-Pounds
C	(3)	5/16-18 x 1-1/4	10 Foot-Pounds
D	(1)	5/16-18 x 5/8	10 Foot-Pounds
E	(2)	3/8-16 x 5/8	22 Foot-Pounds

**ENGINE FRONT COVER BOLT LOCATIONS & TORQUE SPECIFICATIONS****FRONT COVER OIL SEAL**

**Removal & Installation** — Remove crankshaft pulley hub and spacer. Using a thin-bladed screwdriver, pry out front cover oil seal and discard. Lubricate new oil seal using wheel bearing grease. Position seal on end of crankshaft with spring side toward engine. Using suitable tool (J-22770) drive seal into front cover until it bottoms.

<b>CAMSHAFT</b>			
Engine	Journal Diam.	Clearance	Lobe Lift
500"	.....	.001-.0022"	Int. .266" Exh. .275"

① Wear limit .004"

**CAMSHAFT**

**Removal** — **NOTE** — On Eldorado models, engine must be removed from vehicle. Remove radiator, front cover, ignition distributor, oil pump and fuel pump. Remove oil slinger from crankshaft. Remove bolt securing fuel pump eccentric to camshaft and remove eccentric. Remove bolts securing

## 500" CADILLAC V8 (Cont.)

camshaft sprocket to camshaft and remove camshaft sprocket with chain attached. Remove valve lifters and slide camshaft forward carefully until free from engine.

**Installation** — Apply a thin coat of rear axle lubricant to all camshaft lobes and bearing journals and guide camshaft carefully into cylinder block. Reverse removal procedures while

noting following: Extreme care must be exercised to avoid nicking or scratching camshaft bearings. Install camshaft sprocket in timing chain with timing mark toward front, place chain over crankshaft sprocket and line up timing marks on both sprockets (see illustration). Index hole in camshaft must line up with index hole in sprocket.

### CAMSHAFT BEARINGS

**Installation** — Install new plug in rear of No. 5 bearing bore and seal plug with suitable sealer. Scribe a reference mark on front face of each bore to indicate position of center oil passage. Using suitable tool install bearings, lining up oil hole in bearing with scribe mark on front face of bore.

**Removal** — Remove camshaft and use suitable tool (J-21054) to remove bearings. Drive No. 1 bearing through rear face of bearing bore and remove from tool. Remove remaining bearings in same manner. **NOTE** — When removing No. 5 bearing, drive out rear plug along with bearing.

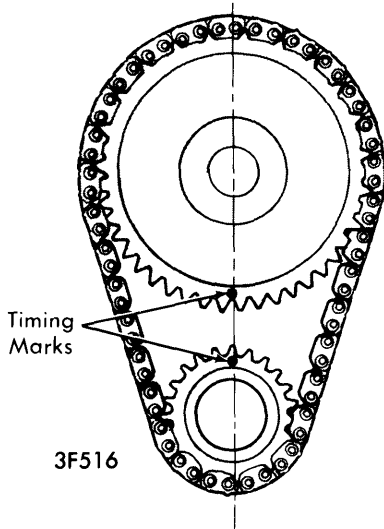

TIMING CHAIN SPROCKET ALIGNMENT

VALVE TIMING				
Engine	INTAKE		EXHAUST	
	Open (BTDC)	Close (ABDC)	Open (BBDC)	Close (ATDC)
500"	21°	111°	73°	55°

### ENGINE OILING

**Crankcase Capacity** — 4 quarts except Eldorado which is 5 quarts. Add one quart with filter change.

**Oil Filter** — Change at first oil change and every second oil change after that.

**Normal Oil Pressure** — 35-40 psi at 30 MPH. Average pressure at idle is 10 psi.

**Pressure Regulator Valve** — Not adjustable.

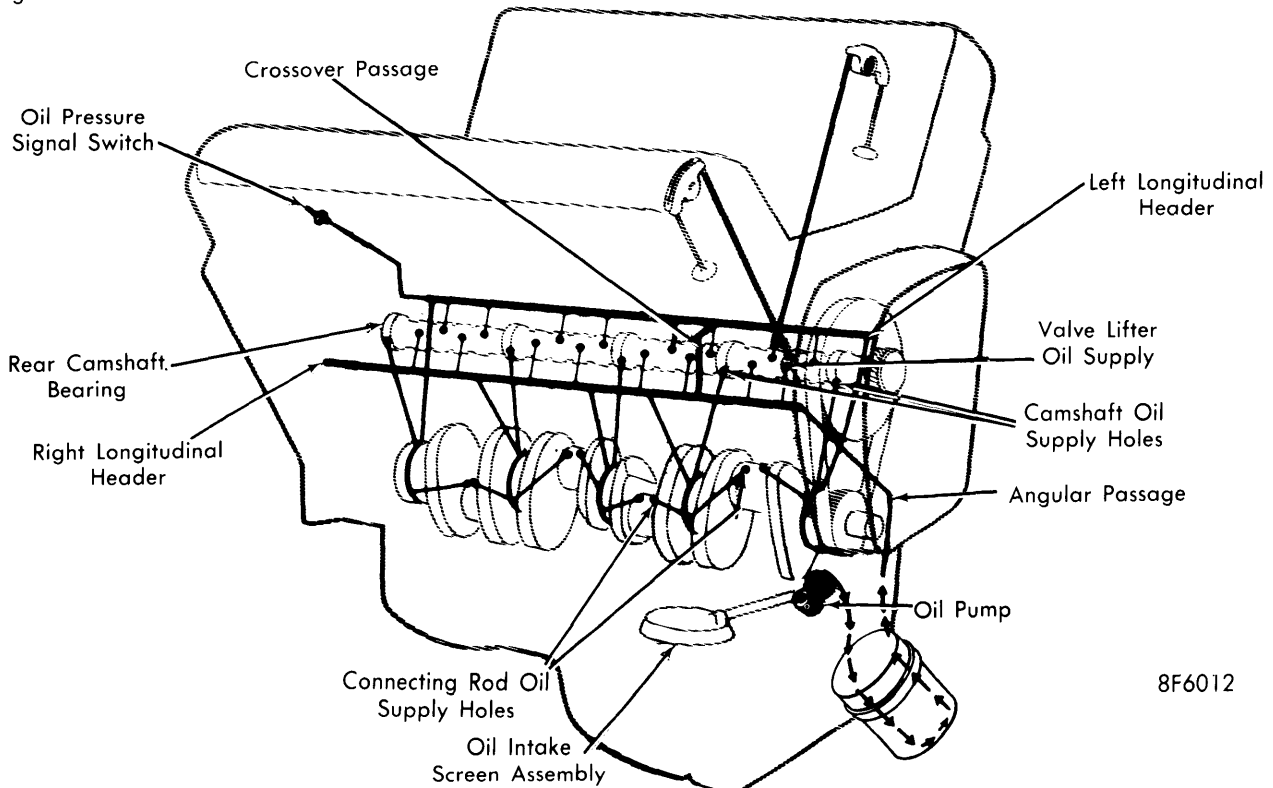

ENGINE OILING SYSTEM

8F6012

# General Motors V8 Engines

## 500" CADILLAC V8 (Cont.)

### ENGINE OILING (Cont.)

#### ENGINE OILING SYSTEM

See *Engine Oiling System Illustration*. Right longitudinal header is fed through angular passage from oil filter and pump. Oil crosses to left longitudinal header through intersecting vertical passages above No. 2 camshaft bearing, continues up vertical header to oil pressure signal switch.

**Crankshaft, Camshaft & Connecting Rods** — Main bearings No. 2, 3 and 4 are lubricated from right longitudinal header through holes drilled in block. Main bearings No. 1 and 5 are lubricated in same manner from left header. Camshaft bearings are lubricated from corresponding main bearings through holes in block. Connecting rod bearings are lubricated from adjacent main bearing through holes in crankshaft.

**Lifters, Rocker Arms, Pistons & Pins** — Longitudinal headers feed hydraulic valve lifters under pressure through drilled passages. From lifters, oil flows through hollow push rods to rocker arms, controlled by metering disc in lifter. Oil comes through feed hole in rocker arm, flows onto arm, lubricating

rocker arm pivot points, push rod tips, and valve tips. Pistons, pins and cylinder walls are lubricated by oil splashed up from crankcase. Oil drains from cylinder heads into valve lifter compartment, returns to crankcase through hole on bottom of compartment.

#### OIL PUMP

Oil pump is mounted on right side near front of engine. Remove oil filter. Remove five bolts securing pump to engine, leaving bolt nearest pressure regulator until last. Clean and inspect all parts (see Oil Pump Specifications). Before reinstalling pump, pack with petrolatum.

#### Oil Pump Specifications

Gear Backlash .....	.001-.013"
Gear-to-Body Clearance.....	.001-.004"
Reg. Valve-to-Bore Clearance.....	①.0020-.0035"
Reg. Valve Spring	
Free Length.....	.257-.269"
Pressure @ 1/16".....	7.5-8.5 Lbs.

① — Wear limit .005".

### TIGHTENING SPECIFICATIONS

Application	Ft. Lbs.
Camshaft Sprocket .....	18
Connecting Rod .....	40
Cylinder Head .....	115
Distributor Clamp .....	15
Exhaust Manifold.....	35
Flywheel-to-Converter .....	30
Flywheel-to-Crankshaft.....	75
Front Cover.....	①
Fuel Pump.....	12
Intake Manifold .....	30
Main Bearing.....	90
Oil Pan .....	10
Oil Pump.....	15
Rocker Arm Cover .....	INCH Lbs. 30
Thermostat Housing .....	10
Transmission Housing-to-Block .....	35
Water Pump .....	①

① — See separate illustration.