

General Motors V8 Engines

350" OMEGA & VENTURA 350" & 455" BUICK

GENERAL SPECIFICATIONS						
Engine	Net HP At RPM	Torque (Ft. Lbs. at RPM)	Compr. Ratio	Bore	Stroke	Displ. Cu. Ins.
350" 2-Bbl.	145@3200	270@2000	8.1:1	3.800"	3.580"	350
350" 4-Bbl.	165@3800	260@2200	8.0:1	3.800"	3.850"	350
455" 4-Bbl.	205@3800	260@2200	8.0:1	4.312"	3.900"	455

► **NET HORSEPOWER & TORQUE NOTE** — Horsepower and Torque figures given above are NET. Net Horsepower and Torque represents power at the flywheel when the engine is installed in a vehicle, with wide open throttle and all systems operating such as; air cleaner, exhaust system, water pump, generator, oil pump and air conditioning.

ENGINE IDENTIFICATION

Engines are identified by first two letters in production code numbers, located on left side of block below front two spark plugs (350" engines) and on left side of block below rear two spark plugs (455" engines). Code letters are as follows:

Application	Code
Buick	
350" 2-Bbl.	AB
350" 4-Bbl.	AM
455" 4-Bbl.	AF
Oldsmobile Omega	
350" 2-Bbl.	RS, RT
350" 4-Bbl.	RW, RX
Pontiac Ventura	
350" 2-Bbl.	RI, RS
350" 4-Bbl.	RW, RX

ENGINE REMOVAL

See *Engine Removal* at end of *ENGINE* Section.

INTAKE MANIFOLD

Removal — 1) Disconnect battery, remove air cleaner and drain cooling system. Disconnect upper radiator hose and accelerator linkage and bracket. Disconnect downshift linkage if equipped with automatic transmission. Disconnect booster vacuum line and fuel line at carburetor. Remove choke pipe at choke housing and disconnect vacuum modulator line if equipped with automatic transmission.

2) Disconnect idle stop solenoid lead (if equipped). Disconnect distributor wires and temperature sending unit lead. Disconnect vacuum hoses from distributor TVS, EFE valve pipe, and vacuum tank hose. Disconnect coolant by-pass hose at manifold. Remove accelerator linkage springs. Remove intake manifold and carburetor as an assembly.

Installation — Clean all gasket surfaces and position new intake manifold gasket and rubber manifold seals in position at front and rear rails of cylinder block. Apply suitable sealer to ends of manifold seals. **NOTE** — Ensure that pointed end of seal fits snugly against block and head. Install one piece manifold gasket and carefully set intake manifold on engine block dowel pin. Install bolts and tighten in sequence (see illustration).

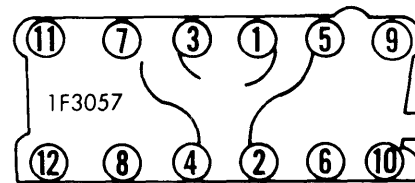

INTAKE MANIFOLD TIGHTENING SEQUENCE

CYLINDER HEAD

NOTE — Depending on vehicle model and cylinder head being removed, removal procedures will vary.

The following procedures apply to right cylinder head on all models:

Removal — Remove intake manifold as previously outlined. Remove drive belts, and disconnect wires from alternator and remove alternator. Remove air conditioning compressor (if equipped) from mount, without disconnecting lines, and position out of way. Disconnect wires from spark plugs. Remove exhaust manifold retaining bolts. Remove valve cover, rocker arm assembly and push rods. Mark push rods to ensure that they are installed in original position. Remove cylinder head.

The following procedures apply to left cylinder head for all models except Apollo, Omega and Ventura:

Removal — Remove intake manifold as previously outlined. Remove dip stick. Remove power steering pump and mount, without disconnecting lines, and position pump out of way. Disconnect wires from spark plugs. Remove exhaust manifold retaining bolts. Remove valve cover, rocker arm assembly and push rods. Mark push rods to ensure that they are installed in original position. Remove cylinder head.

The following procedures apply to left cylinder head for Apollo, Omega and Ventura:

Removal — 1) Remove intake manifold as previously outlined. Remove dip stick. Remove power steering pump and mount, without disconnecting lines, and position pump out of way. Disconnect wires from spark plugs. Remove valve cover, rocker arm assembly and push rods. Mark or position push rods to ensure that they are installed in original position.

2) Remove power brake hose at rear of cylinder head. Raise vehicle and position on safety stands. Disconnect exhaust crossover pipe and support. Remove left front motor mount bolt and loosen right front engine mount bolt. Raise engine

350" OMEGA & VENTURA 350" & 455" BUICK (Cont.)

with a hoist. Remove cylinder head bolts and remove cylinder head. If exhaust manifold does not clear steering gear, engine must be raised further.

Installation (All Models) — Make sure gasket surfaces on cylinder block and head are clean. Make sure cylinder head bolt holes in cylinder block and bolt threads are clean. Place new gasket on cylinder block and position head on cylinder block. Lubricate threads on bolts, install bolts and tighten in sequence shown in illustration. To complete installation, reverse removal procedure for individual vehicles.



CYLINDER HEAD TIGHTENING SEQUENCE

VALVES							
Engine & Valve	Head Diam.	Face Angle	Seat Angle	Seat Width	Stem Diameter	Stem Clearance	Valve Lift
350"							
Int.	1.870-1.880"	45°	45°	.063"	.3720-.3730"	.0015-.0035"
Exh.	1.545-1.555"	45°	45°	.094"	.3723-.3730"	.0015-.0032"
455"							
Int.	1.995-2.005"	45°	45°	.063"	.3720-.3730"	.0015-.0035"
Exh.	1.687-1.692"	45°	45°	.094"	.3723-.3730"	.0015-.0032"

VALVE ARRANGEMENT

E-I-I-E-E-I-I-E (Front to rear both banks).

VALVE GUIDE SERVICING

Guides are integral with cylinder head. If valve stem-to-guide clearance is not within specifications, ream guide to .006" oversize and then to .010" oversize. Valves are available in .010" oversize. **NOTE** — .006" oversize valves are occasionally used in production and identified by oversize marking stamped on valve head. New valves must not be lapped under any conditions as the aluminum alloy surface on the intakes or the nickel-plated surface on exhaust valves will be removed.

VALVE STEM OIL SEALS

Lubricate valve stem and guide, then start seal over valve stem and push down until it touches top of guide. Use suitable tool (J-22509) to push seal over valve guide until upper inside surface of seal touches top of guide. **NOTE** — Do not install seals on exhaust valves.

VALVE STEM INSTALLED HEIGHT

Normal height of valve stem tips above spring seat on head must be 1.933" (350") and 2.082" (455"). If height more than .050" over specification, grind end of valve stem or replace valve.

VALVE SPRINGS			
Engine	Free Length	PRESSURE (LBS.)	
		Valve Closed	Valve Open
350"			
Int.	75-85@1.727"	173-187@1.340"
Exh.	67-77@1.727"	170-184@1.450"
455"			
Int.	67-87@1.890"	170-184@1.450"

VALVE SPRINGS

Removal — Remove cylinder head and use suitable spring compressor (J-8062) to compress valve spring. Remove valve cap retainer, valve cap, spring and valve oil seal (if necessary).

Installation — Install oil seal on intake valve. Install springs with close wound coils toward cylinder head (350" only). Install cap, compress spring and install retainers. **CAUTION** — Compress spring only enough to install retainers to avoid damage to valve stem oil seal.

ROCKER ARM ASSEMBLY

Removal — Remove rocker arm assembly from cylinder head. Remove nylon arm retainers by prying them out using suitable pliers. Remove rocker arms, then remove retainer pieces from inside shaft.

Installation — Install rocker arms on shaft lubricating all parts with engine oil. Center each arm on the 1/4" hole in shaft and install new nylon retainers in holes, using a drift of at least 1/2" diameter. **NOTE** — Service rocker arms are stamped "R" (right) and "L" (left). See illustration for positioning of service rocker arms.

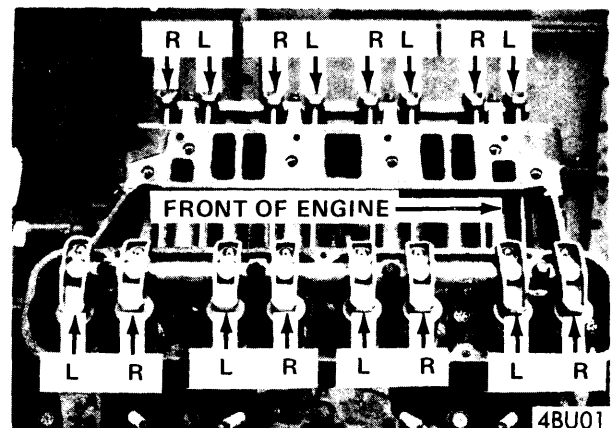

SERVICE ROCKER ARM POSITIONS

350" OMEGA & VENTURA 350" & 455" BUICK (Cont.)

HYDRAULIC VALVE LIFTER ASSEMBLY

NOTE — Lifters are serviced as complete assemblies only. Parts are not interchangeable between lifters. In any component of lifter is worn or damaged, complete lifter must be replaced.

If lifters are disassembled for cleaning and inspection, after reassembly they should be tested using a suitable leak-down tester. Leak-down rate should be 12-60 seconds. Replace lifters which are not within limits.

NOTE — On some engines oversize lifters (.010") are used in production. Bores are marked with an "O" and lifter will be marked with two grooves in lifter body. When replacing lifters, ensure that oversize lifters are installed in oversize bores.

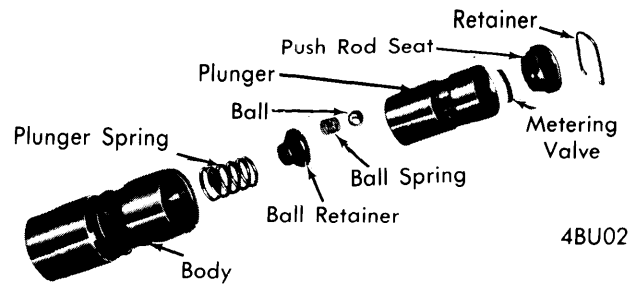

4BU02

HYDRAULIC VALVE LIFTER ASSEMBLY

PISTONS, PINS, RINGS						
Engine	PISTONS	PINS		RINGS		
	① Clearance	Piston Fit	Rod Fit	Rings	End Gap	Side Clearance
350"	.0008-.0020"	.0004-.0007"	.0007-.0017" ②	1	.010-.020"	.003-.005"
				2	.010-.020"	.003-.005"
				3	.015-.035"	.0001-.0035"
455"	.0007-.0013"	.0004-.0007"	.0006-.0016" ②	1	.013-.023"	.003-.005"
				2	.013-.023"	.003-.005"
				3	.015-.035"	.0001-.0035"

① — Measured at top of skirt.

② — Interference fit.

OIL PAN

See Oil Pan Removal at end of ENGINE Section.

PISTON & ROD ASSEMBLY

NOTE — New pistons must be installed in same cylinders for which they were fitted and used pistons in same cylinder from which they were removed.

Removal — With oil pan and cylinder head removed, use a suitable ridge reamer to remove any ridge or deposits on upper end of cylinder bore. **NOTE** — Piston must be at bottom of stroke and covered with cloth to collect cuttings. Inspect connecting rods and caps for cylinder identifications and mark as necessary. Remove rod cap and install suitable guide tools on connecting rod studs. Push piston and rod assembly out top of cylinder block.

Installation — 1) Lightly coat pistons, rings and cylinder walls with engine oil. Position ring gaps as shown in illustration. Make sure compression rings have marks toward top of piston. Install a suitable ring compressor on piston and guide tools on connecting rod studs. Install piston and rod assembly in cylinder bore.

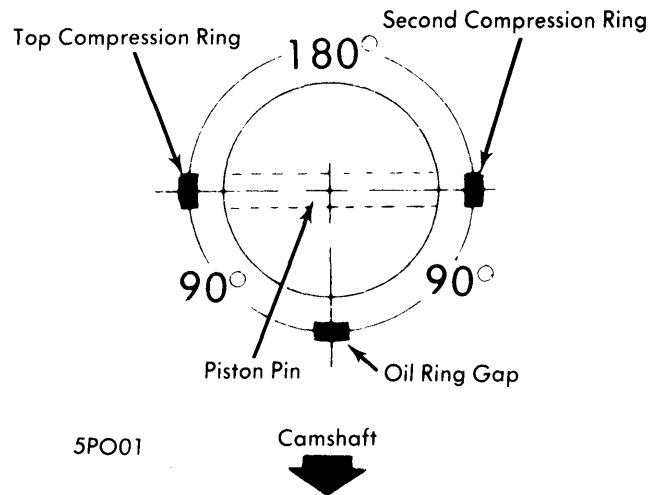

RING GAP POSITIONS

2) When installing piston and rod assembly in engine ensure that notch on piston faces front of engine. On 455", the boss on connecting rod and cap must face front on right bank and to rear on left bank. On 350" right bank, boss on connecting rod must face front and chamfered corners on cap to rear. On left bank, boss faces rear and chamfered corners face front.

3) Guide connecting rod onto crankshaft journal while tapping piston head with hammer handle to seat connecting rod against crankshaft. Remove guide tools from connecting rod studs and install mating rod cap. Tighten rod cap nuts.

350" OMEGA & VENTURA 350" & 455" BUICK (Cont.)

FITTING PISTONS

Pistons are cam ground. Measure piston diameter $\frac{1}{4}$ " below bottom of oil ring groove, at points 90° to the piston pin. Measure cylinder bore diameter 1 ½ -2" from top of bore and check for taper or out-of-round conditions. If cylinder bore is tapered more than .005" or is out-of-round more than .003", cylinders must be rebored and oversize pistons installed.

PISTONS PINS

Pins are selected press fit in rod. Arbor press, driver tool and suitable piston support tool are required to press pin in and out of piston and rod assembly. See specification for proper pin fit in piston and rod. Oversize pins are not practical due to pins being press fit in rod. Pins should fit piston with light thumb press fit at room temperature (70°F). Position piston on rod as shown in illustrations. Piston and rod are assembled differently, depending on bank of engine that piston and rod assembly are being installed into.

Left Bank - 1, 3, 5 & 7

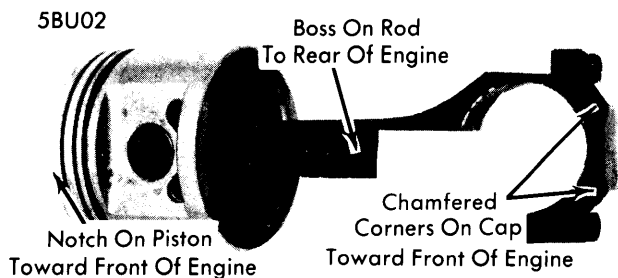

**PISTON & ROD POSITION
LEFT BANK - 350"**

Left Bank - 1, 3, 5 & 7

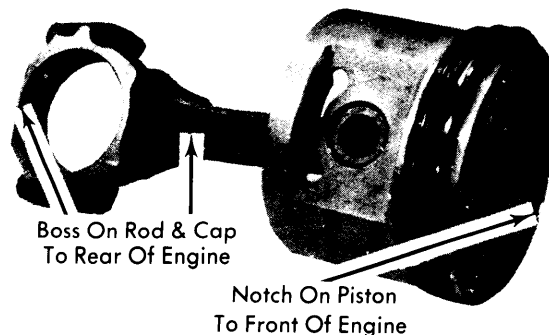

**PISTON & ROD POSITION
LEFT BANK - 455"**

Right Bank - 2, 4, 6 & 8

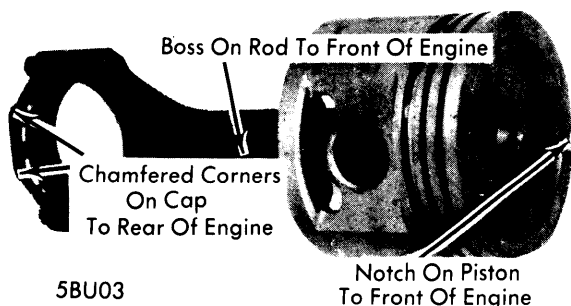

**PISTON & ROD POSITION
RIGHT BANK - 350"**

Right Bank - 2, 4, 6 & 8

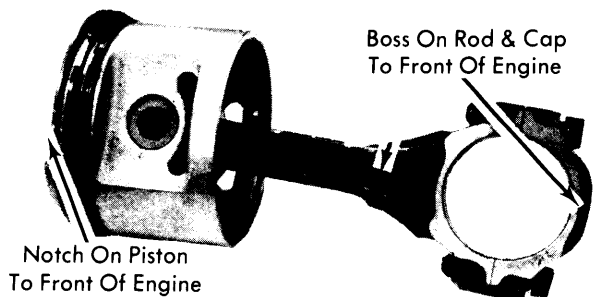

**PISTON & ROD POSITION
RIGHT BANK - 455"**

CRANKSHAFT MAIN & CONNECTING ROD BEARINGS

Engine	MAIN BEARINGS				CONNECTING ROD BEARINGS		
	Journal Diam.	Clearance	Thrust Bearing	Crankshaft End Play	Journal Diam.	Clearance	Side Play
350"	3.0000"	.0004-.0015"	No. 3	.004-.008"	1.9990-2.0000"	.0005-.0026"	.006-.027"
455"	3.2500"	.0004-.0015"	No. 3	.003-.009"	2.2487-2.2495"	.0005-.0026"	.005-.026"

MAIN & CONNECTING ROD BEARINGS

Connecting Rod Bearings - With oil pan removed, ensure rod caps are marked for cylinder identification and remove rod caps. Use Plastigage method to check for proper bearing clearances. If not within specifications, new bearings must be

installed. New bearings are available in standard and .001" undersize. Selective fitting is required on each connecting rod. *NOTE - Always replace bearings in pairs. Never use a new bearing with a used bearing.* Coat bearing surfaces with oil, install rod cap and tighten nuts.

350" OMEGA & VENTURA 350" & 455" BUICK (Cont.)

Main Bearings – 1) Support crankshaft at both front and rear and ensure that all bearing caps, other than one being checked, are tight. Remove one bearing cap at a time and check bearing clearances using Plastigage method. If clearances are not within specifications, bearings are available in standard, .001" and .002" undersizes. **NOTE** – Always replace bearings in pairs. Never use a new bearing with a used bearing. Upper and lower bearings are not interchangeable.

2) Remove all upper main bearings by inserting suitable tool in oil hole of crankshaft journal and rotating crankshaft clockwise to roll bearing from engine. Oil new upper bearing and position against crankshaft so tang on bearing will engage notch in crankshaft when rotated into place. Install main bearing caps with lower bearing installed and tighten bolts. **NOTE** – Arrow on main bearing cap must face forward.

THRUST BEARING ALIGNMENT

To align thrust bearing, move crankshaft forward and to the rear with thrust bearing cap bolts finger tight. Tighten thrust bearing cap bolts. **NOTE** – Last movement to be forward.

REAR MAIN BEARING OIL SEAL

Removal & Installation – 1) Drain crankcase, remove oil pan and rear main bearing cap. Using suitable tool (J-21526-2), drive both ends of oil seal into bearing groove in cylinder block until groove is packed tight. Measure amount seal was driven up into block, add $\frac{1}{16}$ ", then cut this length from the old seal in bearing cap (remove bearing cap seal carefully with a razor blade). Repeat procedure on other side of block.

2) Install suitable guide tool (J-21526-1) onto cylinder block and use packing tool to work new pieces of seal into guide tool and then pack into cylinder block. **NOTE** – Small amount of oil on seal may help installation. Remove guide tool and install a new seal in rear main bearing cap. Use small amount of suitable sealer on rear main bearing cap mating surfaces and install cap to engine. Tighten bolts.

350" Engine Only – Neoprene seals are placed on sides of bearing cap. Seals are slightly undersize when newly installed (and may leak) since neoprene composition swells in presence of heat and oil. Seals are slightly longer than grooves in cap, but must not to cut to length. Soak seals in light oil or kerosene for one to two minutes before installation. After seals are installed, force up into cap with end of hammer handle. **CAUTION** – Operate engine at slow speed when first started after new seals installed.

ENGINE FRONT COVER

Removal – 1) Drain cooling system and disconnect upper and lower radiator hoses at water pump. Remove radiator,

fan, fan pulleys and belts. Remove crankshaft pulley, disconnect fuel lines and remove fuel pump. Remove alternator and brackets.

2) Remove distributor cap with wires attached and swing aside. Remove distributor primary wire, then remove distributor. Loosen and slide front clamp on thermostat by-pass hose rearward. Remove harmonic balancer. Remove bolts attaching oil pan to front cover and cover to cylinder block. Remove front cover and gasket.

Installation – Reverse removal procedure and observe the following:

1) Remove oil pump cover and pack space around gears with petroleum jelly. There must be no air space left inside pump. If pump is not packed, it may not pump oil when engine is started.

2) Clean all gasket surfaces, install new gasket and position front cover against block. Ensure dowel pins engage pin holes before installing and tightening bolts. Use suitable sealer on bolts.

FRONT COVER OIL SEAL

Removal & Installation – Drive out old seal and shedder with a punch. Coil new packing around opening so that ends are at top. Use suitable punch to drive in shedder and stake in place at least three places. Size packing by rotating a hammer handle around packing until balancer hub can be inserted through the opening.

CAMSHAFT			
Engine	Journal Diam.	Clearance	Lobe Lift
350" & 455"	1.785-1.786"	① .0005-.0025" ② .0005-.0035"

① – Journal no. 1.

② – Remaining journals.

TIMING CHAIN

Removal 350" Engine – Remove timing chain cover and align sprocket timing marks (see illustration). Remove front crankshaft oil slinger, then distributor drive gear and fuel pump eccentric from camshaft. Using two large screwdrivers, alternately pry the camshaft and crankshaft sprockets forward until camshaft sprocket is free. Remove camshaft sprocket and chain. Work crankshaft sprocket off shaft.

Removal 455" Engine – Remove timing chain cover and align sprocket timing marks (see illustration). Remove front crankshaft oil slinger, oil pan and camshaft sprocket bolts. Using two large screwdrivers, alternately pry the camshaft and crankshaft sprockets forward until camshaft sprocket is free. Remove camshaft sprocket and chain. Work crankshaft sprocket off shaft.

350" OMEGA & VENTURA 350" & 455" BUICK (Cont.)

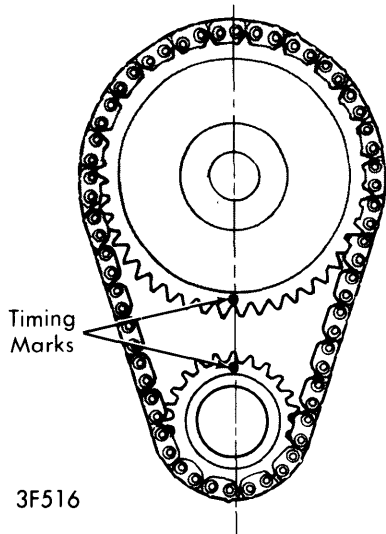

TIMING CHAIN SPROCKET ALIGNMENT

Installation All Engines — Assemble timing chain on sprockets and slide assembly on the shafts with timing marks aligned (see illustration). Reverse removal procedure and tighten all bolts.

CAMSHAFT

Removal — Remove intake manifold, rocker arm shaft assembly, push rods and valve lifters. Remove radiator and front cover. Remove timing chain and sprockets and carefully slide camshaft forward out of bearing bores.

Installation — Reverse removal procedure taking care not to mar the bearing surfaces.

CAMSHAFT BEARINGS

Engine must be removed from car and crankshaft removed from engine to install new camshaft bearings. Slightly scored bearings will be satisfactory if camshaft journals are polished and bearings cleaned up to remove burrs, and if the fit of shaft in bearings is free and within clearances. Special remover and installer tools will be required to replace cam bearings in block. Align boring will not be necessary as precision replacement bearings are available.

ENGINE OILING

Crankcase Capacity — 4 quarts. Add 1 quart with filter change.

Oil Filter — Replace at first oil change and then every second change after that.

Normal Oil Pressure — 350" is 37 psi at 2600 RPM.
455" is 40 psi at 2400 RPM.

Pressure Regulator Valve — In oil pump. Not adjustable.

ENGINE OILING SYSTEM

Lubrication is force-feed type. Oil is supplied under full pressure to crankshaft, connecting rods, and camshaft bearings. Controlled volume of oil is supplied to valve lifters, rocker arms and push rods.

Oil pump is located in timing chain cover and receives oil from crankcase by a drilled passage to pickup pipe. Oil passes through full-flow oil filter, equipped with by-pass valve, and to main oil galleries which run full length of crankcase and supply oil to valve lifters, camshaft bearings, main and connecting rod bearings. Pistons, cylinder walls, piston pins, distributor gears and timing chain and sprockets are lubricated by splash, gravity flow, or spurt holes. Rocker arms and valves are supplied with oil through tubular push rods.

OIL PUMP

Inspection — Clean gears and inspect for wear or scoring. Remove relief valve and spring. Oil filter by-pass valve and spring are staked in place and should not be removed. Replace

any relief valve spring which is worn on its side. Relief valve should have no more clearance in its bore than an easy slip fit. If any side play is present, valve and cover should be replaced.

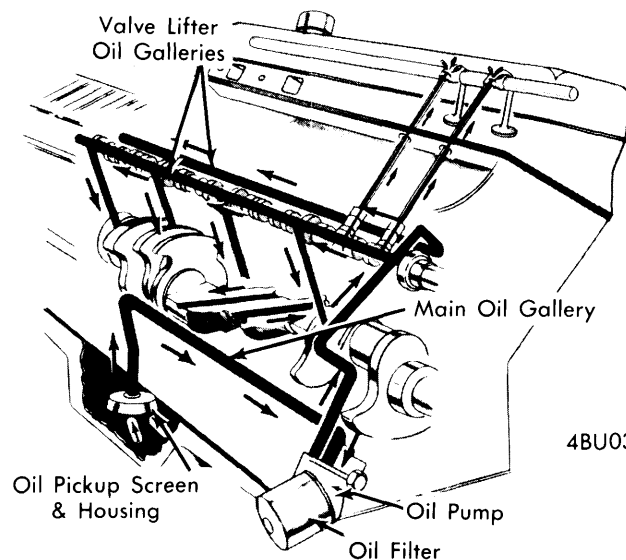

ENGINE OILING SYSTEM

Reassembly — Oil relief valve before installation. Place straight edge across gears and clearance to cover gasket should be .0023-.0058". If less than .0018" check timing chain cover gear pocket for evidence of wear. Replace cover and tighten bolts. **NOTE** — Pump cavity and gears must be packed with petroleum jelly or pump may not prime itself when engine is started. Do not use chassis lube.

General Motors V8 Engines

350" OMEGA & VENTURA 350" & 455" BUICK (Cont.)

ENGINE OILING (Cont.)

TIGHTENING SPECIFICATIONS

FT. LBS.

Application	350"	455"
Camshaft Sprocket Bolt.....	48	22
Connecting Rod Caps.....	40	45
Cylinder Head	80	100
Exhaust Manifold.....	28	28
Flywheel	60	60
Front Cover.....	30	30
Fuel Pump.....	20	20
Intake Manifold	45	45
Main Bearing Caps	115	115
Oil Pan-to-Block.....	14	14
Oil Pump Cover	10	10
Rocker Arm Shaft.....	30	30
Thermostat Housing	20	20
Vibration Damper.....	150 ①	200 ①
Water Pump	7	7

① — Minimum torque.