

262", 350" & 400" CHEVROLET V8

GENERAL SPECIFICATIONS						
Engine	Net HP At RPM	Torque (Ft. Lbs. at RPM)	Compr. Ratio	Bore	Stroke	Displ. Cu. Ins.
262" 2-Bbl.	110 @ 3600	200 @ 2000	8.5:1	3.67"	3.10"	262"
350" 2-Bbl.	145 @ 3800	250 @ 2200	8.5:1	4.00"	3.48"	350"
350" 4-Bbl.	155 @ 3800	250 @ 2400	8.5:1	4.00"	3.48"	350"
350" 4-Bbl.	165 @ 3800	255 @ 2400	8.5:1	4.00"	3.48"	350"
350" 4-Bbl.	205 @ 4800	255 @ 3600	9.0:1	4.00"	3.48"	350"
400" 4-Bbl.	175 @ 3600	305 @ 2000	8.5:1	4.125"	3.75"	400"

NOTE — Horsepower and Torque figures given above are NET. Net Horsepower and Torque represents power at the flywheel when the engine is installed in a vehicle, with wide open throttle and all systems operating such as; air cleaner, exhaust system, water pump, generator, oil pump and air conditioning.

ENGINE IDENTIFICATION

Engine code is stamped on front right side of cylinder block. Suffix (code) letters designate engine displacement as follows:

Application	Code
262"	CZA, CZB, CZC, CZD, CZT, CZU, CZW, CZF, CZH, CZJ, CZK, CZL, CZM
350"	CR2, CMU, CMX, CMY, CRC, CRD, CRF, CRS, CRR, CRT, CRU, CRW, CRX, CRY, CRZ, CUC, CUH, CUJ, CUK, CUL, CUM, CUS, CRJ, CRK, CRL, CRM, CUT, CUA, CUB, CUD
400"	CHS, CSH, CSR, CSS, CST, CSL, CTM, CTR, CTS

ENGINE REMOVAL

See Engine Removal at end of ENGINE Section.

INTAKE MANIFOLD

Removal — 1) Drain radiator and remove air cleaner. Disconnect battery cables, upper radiator hose and heater hose at manifold, accelerator linkage at pedal lever, and fuel line at carburetor. Disconnect temperature sending unit and coil wires, power brake hose at carburetor base or manifold, and crankcase ventilation hoses as required.

2) Disconnect distributor vacuum hose and choke secondary pull-off lead. Remove air conditioning bracket and/or power steering pump support (if equipped). Remove cold and hot air tubes for choke and carburetor choke hot air tube assembly.

3) Remove distributor cap and position to rear of distributor. Mark rotor position to aid in distributor installation. Remove distributor clamp and remove distributor. Remove delcotron upper bracket and A.I.R. pump. Remove manifold to cylinder head bolts and remove manifold and carburetor as an assembly.

Installation — Clean gasket and seal surfaces on manifold, cylinder heads and block. Install end seals on block. Install side gaskets on cylinder heads using sealing compound around water passages. Install manifold being careful not to displace gaskets and seals. Install manifold bolts and tighten in sequence (see illustration). **NOTE** — If crankshaft has been rotated while distributor was removed, time distributor to No. 1 cylinder.

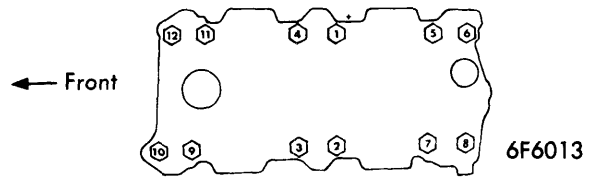

INTAKE MANIFOLD TIGHTENING SEQUENCE

Installation — Clean gasket surfaces on block and cylinder heads. Clean head bolt threads and threads in block (dirt will affect torque). Use sealer on both sides of steel gaskets. **NOTE** — Do not apply sealer to composition gaskets. Place gaskets in position on block with bead up. Install cylinder heads and bolts (with sealing compound on threads). Tighten bolts evenly, a little at a time, in sequence (see illustration).

CYLINDER HEAD

Removal — Remove intake manifold and carburetor as an assembly. Remove A/C and power steering components as necessary. Remove exhaust manifolds. Remove rocker arm cover, rocker arm nuts, balls and rocker arm. Remove push rods. **NOTE** — Valve mechanism components must be reinstalled in same location. Drain cooling system and remove cylinder head bolts. Remove cylinder head and gaskets.

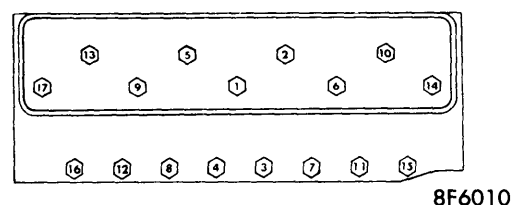

CYLINDER HEAD TIGHTENING SEQUENCE

General Motors V8 Engines

262", 350" & 400" CHEVROLET V8 (Cont.)

VALVES							
Engine & Valve	Head Diam.	Face Angle	Seat Angle	Seat Width	Stem Diameter	Stem Clearance	Valve Lift
262"							
Int.	1.715-1.725"	45°	46°	.031-.063"	.3410-.3417"	.0010-.0027"
Exh.	1.495-1.505"	45°	46°	.063-.094"	.3410-.3417"	.0010-.0027"
350" & 400"							
Int.	1.935-1.945"	45°	46°	.031-.063"	.3410-.3417"	.0010-.0027"
Exh.	1.495-1.505"	45°	46°	.063-.094"	.3410-.3417"	.0010-.0027"

VALVE ARRANGEMENT

E-I-I-E-E-I-I-E (Both banks, front to rear).

VALVE GUIDE SERVICING

Integral with cylinder head. If valve stem clearance excessive, ream to next oversize.

VALVE STEM OIL SEALS

An "O" ring type seal is installed in lower groove on valve stem after valve spring is compressed and before keepers are installed. See *Valve Springs*.

spring. **CAUTION** — Do not shim spring to give installed height less than specification.

Application

ⓐ Installed Height

262" & 350"ⓐ

 Int. 1 5/8"

 Exh. 1 23/32"

350" & 400"ⓑ 1 23/32"

ⓐ — Specification is ± 1/32".

ⓑ — Except 205 HP 350".

ⓒ — 205 HP 350".

VALVE SPRINGS			
Engine	Free Length	PRESSURE (LBS.)	
		Valve Closed	Valve Open
262" & 350"ⓐ			
Int.	2.03"	76-84@1.70"	194-206@1.25"
Exh.	1.91"	76-84@1.61"	183-195@1.20"
350" & 400"ⓑ	2.03"	76-84@1.61"	194-206@1.25"

ⓐ — Exc. 205 HP 350"

ⓑ — 205 HP 350".

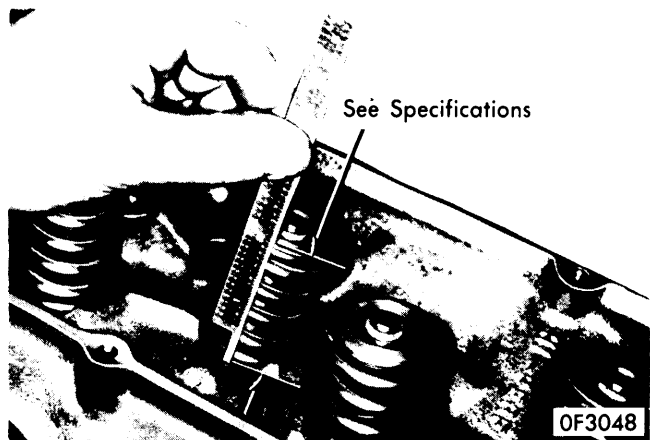

MEASURING SPRING INSTALLED HEIGHT

VALVE SPRINGS

Removal — Remove rocker arm cover, rocker arms and push rods on cylinders to be serviced. Install air line adapter in spark plug hole and apply compressed air to hold valves in place. Using a suitable tool (J-5892) to compress valve spring, remove valve keepers and release tool. Remove upper spring retainer, shield, and spring and damper.

NOTE — Before reinstalling old springs, check with a suitable spring tester. Springs should be replaced if not within 10 lbs. of specified load.

Installation — Position valve spring and damper, shield, and retainer on valve stem. Compress valve spring and install oil seal in lower groove. Make sure that seal is flat and not twisted. Install valve keepers and release compressor tool. Check that valve locks are properly seated in upper groove in valve stem.

VALVE SPRING INSTALLED HEIGHT

Measured from spring seat (or top of shim) to top of valve spring shield. If not within specifications, install 1/16" spacer under

ROCKER ARM STUDS

Rocker arm studs are available .003" and .013" oversize. Remove old stud using a suitable tool with a flat washer and a nut. Tighten nut to pull stud from cylinder head. Ream stud hole in cylinder head using a suitable reamer (J-5715 for .003" oversize and J-6036 for .013" oversize). **CAUTION** — Do not attempt to install oversize stud without first reaming hole. Coat press fit area of stud with hypoid axle lubricant. Drive stud in place using a suitable tool (J-6880) and a hammer. Tool will bottom out on cylinder head when stud is installed at correct height.

HYDRAULIC VALVE LIFTER ASSEMBLY

NOTE — Lifters are serviced as complete assemblies only. Parts are not interchangeable between lifters. If any component of lifter is worn or damaged, complete lifter must be replaced. If lifters are disassembled for cleaning and inspection, after reassembly they should be tested using a leak down tester following manufacturers instructions. Before installing lifters, coat bottom of lifter with Molykote.

262", 350" & 400" CHEVROLET V8 (Cont.)

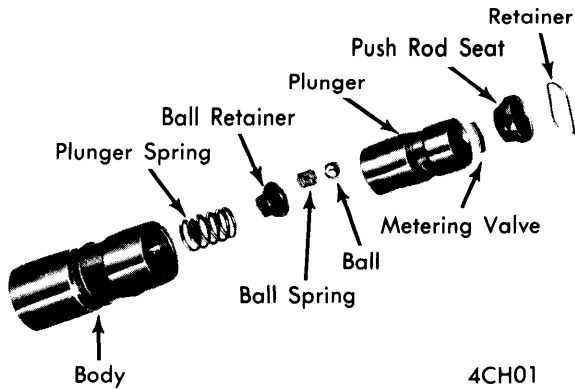

HYDRAULIC VALVE LIFTER

HYDRAULIC VALVE LIFTER ADJUSTMENT

With No. 1 cylinder at TDC firing position, adjust exhaust valves No. 1,3,4,8 and intake valves 1,2,5,7 as follows:

1) Back off rocker arm stud adjusting nut until there is play in push rod, then tighten nut until push rod-to-rocker arm clearance is removed. Tighten nut one additional turn from this point (places lifter plunger in center of its travel).

2) Crank engine one complete revolution so No. 6 cylinder is at TDC firing position and adjust exhaust valves No. 2,5,6,7 and intake valves No. 3,4,6,8 in same manner.

PISTONS, PINS, RINGS						
Engine	PISTONS		PINS		RINGS	
	Clearance	Piston Fit	Ⓢ Rod Fit	Rings	End Gap	Side Clearance
262"	.0007-.0013"	.00025-.00035"	.0008-.0021"	1	.010-.020"	.0012-.0032"
				2	.013-.025"	.0012-.0032"
				3	.015-.055"	.002-.007"
350" 145 HP	.0005-.0011"	.00015-.00025"	.0008-.0016"	1	.010-.020"	.0012-.0027"
				2	.010-.020"	.0012-.0032"
				3	.015-.055"	.000-.005"
155 HP	.0007-.0013"	.00015-.00025"	.0008-.0016"	1	.010-.020"	.0012-.0032"
				2	.013-.025"	.0012-.0032"
				3	.015-.055"	.000-.005"
165 HP	.0007-.0013"	.00015-.00025"	.0008-.0016"	1	.010-.020"	.0012-.0032"
				2	.013-.025"	.0012-.0032"
				3	.015-.055"	.002-.007"
205 HP	.0036-.0042"	.00045-.00055"	.0008-.0016"	1	.010-.020"	.0012-.0032"
				2	.010-.023"	.0012-.0027"
				3	.015-.055"	.000-.005"
400"	.0014-.0020"	.00015-.00025"	.0008-.0016"	1	.010-.020"	.0012-.0027"
				2	.010-.020"	.0012-.0032"
				3	.015-.055"	.000-.005"

Ⓢ - Interference fit.

OIL PAN

See Oil Pan Removal at end of ENGINE Section.

PISTON & ROD ASSEMBLY

NOTE - New pistons must be installed in same cylinders for which they were fitted and used pistons in same cylinder from which they were removed.

Removal - With oil pan, oil pump and cylinder head removed, use a suitable ridge reamer to remove any ridge or deposits on upper end of cylinder bore. **NOTE** - Piston must be at bottom of stroke and covered with cloth to collect cuttings. Inspect connecting rods and caps for cylinder identification and mark as necessary. Remove rod cap and install suitable tool on connecting rod studs. Push piston and rod assembly out top of cylinder block.

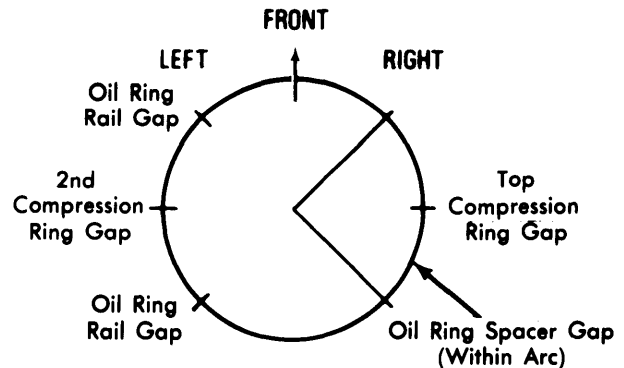

4FO02

RING GAP LOCATION

General Motors V8 Engines

262", 350" & 400" CHEVROLET V8 (Cont.)

Installation — Lightly coat pistons, rings and cylinder walls with engine oil. Ensure ring gaps are properly spaced (see illustration) and install ring compressor on piston. Pistons are installed with connecting rod bearing tang slots on side opposite camshaft. **NOTE** — Piston assemblies must be installed in correct cylinder. From front to rear 1, 3, 5, 7 on left bank and 2, 4, 6, 8 on right bank. Guide connecting rod onto crankshaft journal while tapping piston head with hammer handle to seat connecting rod against crankshaft. Remove tool from studs and install mating rod cap. Tighten rod cap nuts.

FITTING PISTONS

Measure pistons across centerline of piston pin. Measure cylinder bore diameter approximately 2 1/2" from top of bore. The difference between the two diameters will be the piston to bore clearance. If clearance exceeds specifications, cylinder block must be bored and oversize pistons installed. Pistons and rings are available .001" and .030" oversize.

PISTON PINS

Measure piston pin and bore in piston. If clearance is not within specifications, replace piston and pin. Use suitable tool

set and arbor press (see illustration) to press pin in and out of rod. Check freedom of piston on pin after pressing operation.

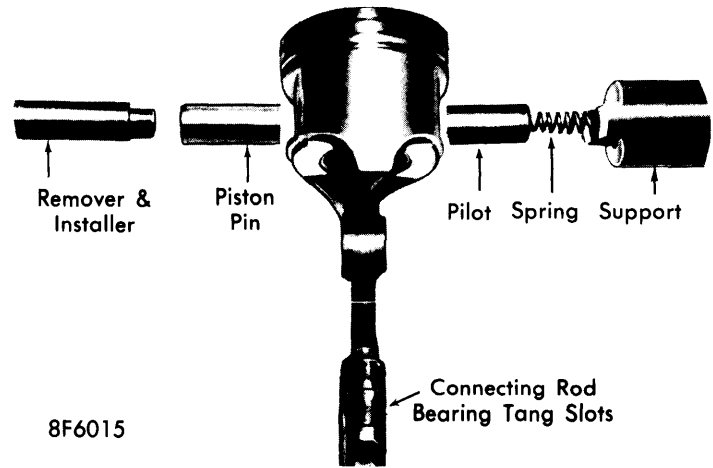

PISTON PIN TOOL SETUP (TYPICAL)

CRANKSHAFT MAIN & CONNECTING ROD BEARINGS							
Engine	MAIN BEARINGS				CONNECTING ROD BEARINGS		
	Journal Diam.	Clearance	Thrust Bearing	Crankshaft End Play	Journal Diam.	Clearance	Side Play
262"	①2.4484-2.4493" ②2.4481-2.4490" ③2.4479-2.4488"	①.0008-.0020" ②.0011-.0023" ③.0017-.0033"	No. 5	.002-.007"	2.098-2.099"	.0013-.0035"	.008-.014"
350" Exc. 205 HP	①2.4484-2.4493" ②2.4481-2.4490" ③2.4479-2.4488"	①.0008-.0020" ②.0011-.0023" ③.0017-.0033"	No. 5	.002-.006"	2.099-2.100"	.0013-.0035"	.008-.014"
350" 205HP Man. Trans.	①2.4484-2.4493" ②2.4481-2.4490" ③2.4479-2.4488"	④.0013-.0025" ③.0023-.0033"	No. 5	.002-.006"	2.099-2.100"	.0013-.0035"	.008-.014"
Auto. Trans.	①2.4484-2.4493" ②2.4481-2.4490" ③2.4479-2.4488"	①.0019-.0031" ②.0013-.0025" ③.0023-.0033"	No. 5	.002-.006"	2.099-2.100"	.0013-.0035"	.008-.014"
400"	④2.6484-2.6493" ③2.6479-2.6488"	①.0008-.0020" ②.0011-.0023" ③.0017-.0033"	No. 5	.002-.006"	2.099-2.100"	.0013-.0035"	.008-.014"

- ① — Journal No. 1.
- ② — Journal Nos. 2, 3 and 4.
- ③ — Journal No. 5.
- ④ — Journal Nos. 1, 2, 3 and 4.

MAIN & CONNECTING ROD BEARINGS

NOTE — Following procedures are performed with oil pan and oil pump removed.

Connecting Rod Bearings — After ensuring rod caps are marked for cylinder identification, remove rod caps. Use Plastigage method to check for proper bearing clearances. If not within specifications, new bearings must be installed. New bearings are available in standard, .001" and .002" under-

size. Selective fitting is required on each connecting rod. A standard bearing may be used in combination with a .001" undersize or a .002" undersize. Coat bearing surfaces with oil, install rod cap and tighten nuts.

Main Bearings — 1) Support crankshaft at both front and rear (damper and flywheel) and ensure that all bearing caps, other than one being checked, are tight. Starting with rear main bearing cap and working forward, remove one cap at a time and check bearing clearances using Plastigage method.

262", 350" & 400" CHEVROLET V8 (Cont.)

2) If clearances are not within specifications, new bearings are available in .001", .002", .010" and .020" undersize. One half of a standard size bearing can be used in conjunction with one half of a .001" undersize bearing to obtain proper clearance. **NOTE** — Some production crankshafts are ground .009" undersize. A engine fitted with a undersize crankshaft is identified by .009" stamped on crankshaft counterweight forward of center main journal. A figure "9" will be stamped on block at left front oil pan rail.

3) Remove all main bearing upper halves (except rear main) by inserting suitable tool in oil hole of crankshaft journal and rotating crankshaft clockwise to roll bearing from engine. Oil new upper bearing and insert plain (unnotched) end between crankshaft and indented (or notched) side of block. Rotate bearing into place.

4) To replace rear main bearing upper half, use a small drift punch and hammer to start bearing rotating out of block. **NOTE** — Take care not to nick crankshaft journal. Use a pair of pliers (with taped jaws) to hold bearing thrust surface to oil slinger and rotate crankshaft to remove bearing. Oil new bearing and insert plain (unnotched) end between crankshaft and indented (or notched) side of block. Use pliers, as in removing, to rotate bearing into place.

5) Main bearing caps are to be installed with arrow pointing forward. Tighten main bearing bolts except rear main. Torque rear main bolts 10-12 ft. lbs. and tap end of crankshaft first rearward, then forward to line up rear main bearing with crankshaft thrust face. Tighten all main bearing cap bolts. Rotate crankshaft to ensure there is no excessive drag.

REAR MAIN BEARING OIL SEAL

NOTE — Replace upper and lower seal halves as a unit. Install seal with lip facing front of engine. With oil pan and oil pump removed, proceed as follows:

Removal — Remove rear main bearing cap and remove seal from cap. Use a small brass drift punch to tap upper seal until end protrudes far enough to be removed with pliers.

Installation — 1) Coat seal lips and bead with light engine oil, keeping oil off seal mating ends. To replace upper seal, fabricate a tool from .004" shim stock (see illustration). Position tip of tool between crankshaft and seal seat, then position seal between crankshaft and tip of tool so seal bead contacts tip of tool.

2) Roll seal around crankshaft using tool as a "shoehorn" to protect seal bead from sharp corner of seal seat surface. Remove tool, being careful not to withdraw seal. **CAUTION** — Installation tool must remain in position until seal is positioned with both ends flush with block.

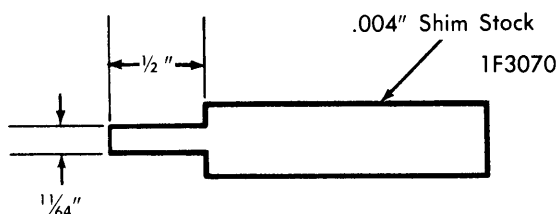

REAR MAIN SEAL INSTALLING TOOL

3) Install lower seal in bearing cap, using tool as a "shoehorn". Feed seal into cap using light pressure with thumb and finger. Apply sealant to bearing cap interface, being careful to keep sealant off seal split line. Install bearing cap and tighten bolts.

TORSIONAL VIBRATION DAMPER

Removal — Remove fan, pulley, radiator and shroud. **NOTE** — If camshaft is not being removed, radiator will not need to be removed. Remove accessory drive pulley and damper retaining bolt. Using a suitable puller, remove damper from crankshaft.

Installation — **CAUTION** — Use suitable installer tool to prevent inertial weight section from walking off hub during installation. Coat seal contact area of damper with oil. Place damper over key on crankshaft, pull damper onto shaft. Install damper bolt and tighten.

ENGINE FRONT COVER

Removal — Remove torsional damper and water pump. Remove crankcase front cover bolts and two oil pan to front cover attaching bolts. Remove front cover.

Installation — 1) Make sure gasket surface on block and engine front cover is clean. Remove any excess oil pan gasket, at oil pan and engine junction, using a knife. Apply a 1/8" bead of silicone rubber sealer at oil pan and block junction. Coat cover gasket with sealer and position on cover.

2) Position cover on cylinder block, install four top screws and tighten approximately three turns. Install two 1/4"-20x1/2" screws at two lower holes in cover, but do not tighten. Apply a bead of silicone sealer to bottom of oil pan to cover seal and position seal on cover.

3) Tighten screws alternately and evenly, while aligning cover on dowel pins with a drift punch. Continue tightening screws until cover is pulled into place. Remove two lower screws, install remaining screws and tighten. Install torsional damper and water pump.

FRONT COVER OIL SEAL

Front Cover Installed On Engine — Remove crankshaft pulley and hub or vibration damper and pry old oil seal out of cover from front side with screwdriver. Install seal with open end of seal toward inside of front cover and drive into place with suitable tool.

Front Cover Removed From Engine — Pry old oil seal out of cover from front side with screwdriver. Support cover at sealing area and install new seal with open end of seal toward inside of front cover. Drive into place with suitable tool.

CAMSHAFT			
Engine	Journal Diam.	Clearance	Lobe Lift
262"	1.8677-1.8697"	⓪
350"	1.8682-1.8692"	⓪
400"	1.9482-1.9492"	⓪

⓪ — See Camshaft Lobe Lift.

262", 350" & 400" CHEVROLET V8 (Cont.)

TIMING CHAIN

Removal — Remove front cover and crank engine until timing marks are aligned (see illustration). Remove camshaft sprocket to camshaft bolts. Remove camshaft sprocket and timing chain together. **NOTE** — Sprocket is a light press fit on camshaft, dislodge by tapping lightly on lower edge of sprocket.

Installation — Install timing chain on camshaft sprocket and hold sprocket vertical with chain hanging and align marks on camshaft and crankshaft sprockets. Align dowel in camshaft with dowel hole in sprocket and install sprocket on camshaft. Draw sprocket onto camshaft using three mounting bolts. **CAUTION** — Do not attempt to drive sprocket on shaft as plug at rear of camshaft can be dislodged. Tighten bolts and lubricate timing chain with oil.

CAMSHAFT

Removal — Camshaft may be removed without removing engine from vehicle using following procedure:

1) Remove valve lifters, radiator, grille (except Nova) and engine front cover. On Nova remove both front mount through bolts and remove right motor mount, then lower engine on frame, remove two center and one lower bolt securing hood catch support to grille and radiator support.

2) Remove fuel pump and push rod. Remove camshaft sprocket and timing chain. Tap sprocket with plastic mallet to loosen it from shaft. Remove camshaft.

Installation — Coat camshaft lobes with Molykote and journals with engine oil. Reverse removal procedure.

CAMSHAFT BEARINGS

NOTE — Following procedures are done with crankshaft and camshaft removed. If piston assemblies remain in engine, tape connecting rods to cylinder walls so they will not be in the way while replacing bearings.

Removal — 1) Drive camshaft rear plug from cylinder block. Using suitable tool (J-6098) with nut and thrust washer installed to end of threads, index pilot in front bearing and install puller screw through pilot. Install remover and installer tool, with shoulder toward bearing, making sure sufficient number of threads are engaged. **NOTE** — Remove bearings nearest center of engine first.

2) Using two wrenches, hold puller screw while turning nut. When bearing has been pulled from bore, remove tool and bearing from puller screw. Remove remaining bearings (except front and rear) in same manner. It is necessary to index pilot in rear bearing to remove rear intermediate bearing. Assemble remover and installer tool on driver handle and remove front and rear bearings by driving towards center of cylinder block.

Installation — Install front and rear bearings first. These bearings will act as guides for the pilot (tool) and will center

remaining bearings as they are pulled into place. As each bearing is installed, make sure oil holes in bearing are aligned with oil holes in block. After all bearings have been installed, install new rear camshaft plug. **NOTE** — Plug should be installed flush to $\frac{1}{32}$ " deep and be parallel with rear surface of block.

CAMSHAFT LOBE LIFT

Remove rocker arm. Attach dial indicator to rocker arm stud or rocker arm cover mounting hole and adjust dial indicator to seat in push rod cup. **NOTE** — Be sure push rod is seated in lifter socket. Rotate crankshaft slowly until lifter is on heel of cam lobe (push rod will be in lowest position). Zero dial indicator and slowly bump engine over until push rod is fully raised. **CAUTION** — If using an auxiliary starter switch, "BAT" terminal at distributor must be disconnected and ignition switch must be "ON". Failure to do this will result in damage to ignition switch. Compare total lift on dial indicator with specifications. Continue to rotate engine until indicator reads zero (for accuracy check of dial indicator).

Application

① Lobe Lift

262"	
Intake2485"
Exhaust2600"
350" (Exc. 205 HP)	
Intake
Exhaust
350" (205 HP)	
Intake3000"
Exhaust2411"
400"	
Intake2235"
Exhaust2411"

① — Specification is $\pm .002$ ".

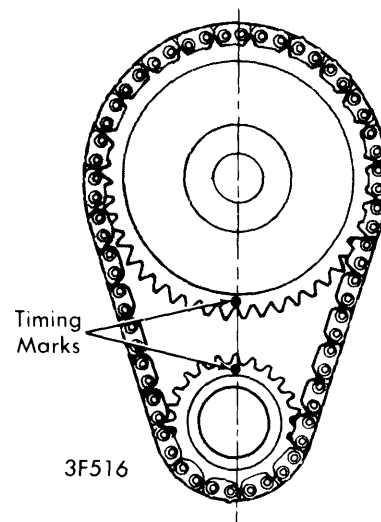

TIMING CHAIN SPROCKET ALIGNMENT

ENGINE OILING

Crankcase Capacity — All engines, 4 quarts. Add 1 quart with oil filter change.

Oil Filter — Replace at first oil change then every second oil change after that.

262", 350" & 400" CHEVROLET V8 (Cont.)

ENGINE OILING (Cont.)

Normal Oil Pressure (Hot) — 40 psi @ 2000 RPM.

Pressure Regulator Valve — In oil pump body. Not adjustable.

ENGINE OILING SYSTEM

Full pressure lubrication through a full flow oil filter is furnished by a gear-type oil pump. Main oil gallery feeds oil, through drilled passages, to camshaft and crankshaft to lubricate bearings. Valve lifter gallery feeds the valve lifters, which feed individual rocker arms through hollow push rods.

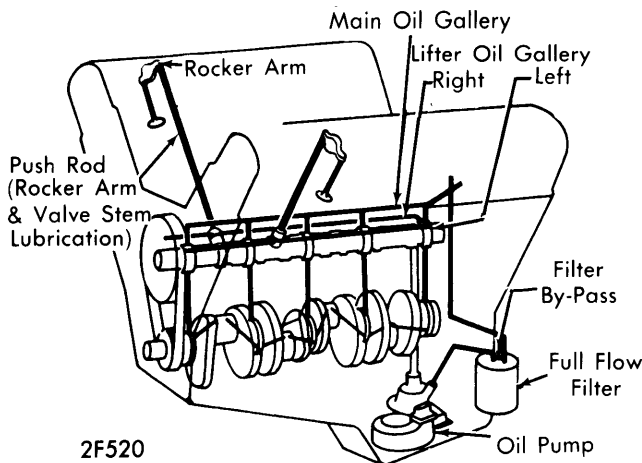

ENGINE OILING SYSTEM — SMALL V8

OIL PUMP

Removal — Mark gears so they may be reassembled with same teeth indexing. Do not disturb pickup screen on pipe. Screen is serviced as an assembly. **NOTE** — If pump gears or body are damaged or worn, replacement of entire pump assembly is necessary.

Installation — Apply sealer to end of pipe and tap in place. Install idler gear in pump body with smooth side of gear towards cover opening. **NOTE** — Bottom of screen must be parallel with bottom of pan.

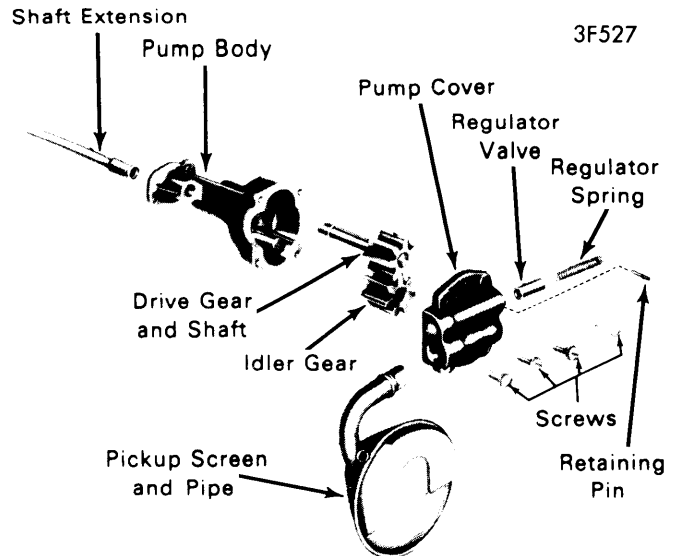

"SMALL V8" OIL PUMP ASSEMBLY

TIGHTENING SPECIFICATIONS

Application	Ft. Lbs.
Cylinder Head	65
Intake Manifold	30
Main Bearing Caps ^①	70
Connecting Rod Cap Bolts	45
Exhaust Manifold ^②	20
Flywheel Bolts	60
Camshaft Sprocket	20
Torsional Damper Bolt	60
Rocker Arm Stud ^③	50
Water Pump	30
Oil Pump	65
Clutch Pressure Plate	35
Water Outlet	30

Application	Inch Lbs.
Oil Pan	
1/4" Bolts	80
3/16" Bolts	265
Front Engine Cover	80
Oil Pump Cover	80

- ① — Outer bolts on 4 bolt caps are 65 ft. lbs.
- ② — Inside bolts on 262" and 350" are 30 ft. lbs.
- ③ — If equipped with screw in type rocker studs.