

General Motors V6 Engines

231" V6

GENERAL SPECIFICATIONS						
Engine	Net HP At RPM	Torque (Ft. Lbs. at RPM)	Compr. Ratio	Bore	Stroke	Displ. Cu. Ins.
231" 2-Bbl.	110@4000	175@2000	8.0:1	3.800"	3.400"	231"

► **NET HORSEPOWER & TORQUE NOTE** — Horsepower and Torque figures given above are NET. Net Horsepower and Torque represents power at the flywheel when the engine is installed in a vehicle, with wide open throttle and all systems operating such as; air cleaner, exhaust system, water pump, generator, oil pump and air conditioning.

ENGINE IDENTIFICATION

Engines are identified by code letters in production code number located on engine. Number is stamped in pad on left front side of engine, next to front engine cover. On some Oldsmobile models, number may be found on left side of engine block below front spark plug.

Application	Code
231" 2-Bbl. Buick	AD
231" 2-Bbl. Oldsmobile	
Man. Trans.	FP
Auto. Trans. (Federal)	FR
Auto. Trans. (Calif.)	FS

ENGINE REMOVAL

See Engine Removal at end of ENGINE Section.

INTAKE MANIFOLD

Removal — 1) Disconnect battery, remove air cleaner and drain cooling system. Disconnect upper radiator hose and accelerator linkage and bracket. Disconnect downshift linkage if equipped with automatic transmission. Disconnect booster vacuum line and fuel line at carburetor. Remove choke pipe at choke housing and disconnect vacuum modulator line if equipped with automatic transmission.

2) Disconnect idle stop solenoid lead (if equipped). Disconnect distributor wires and temperature sending unit lead. Disconnect vacuum hoses from distributor TVS and EFE valve pipe and vacuum tank hose. Disconnect coolant by-pass

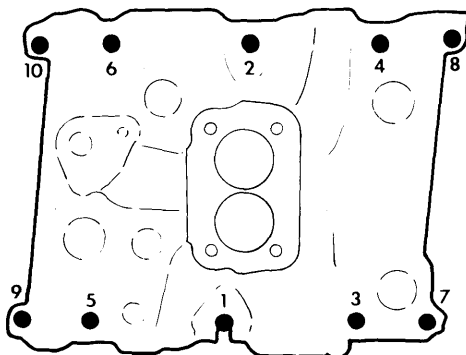

50LA01

INTAKE MANIFOLD TIGHTENING SEQUENCE

hose at manifold. Remove distributor cap and rotor to gain access to intake manifold Torx head bolt. Remove Torx head bolt using a suitable tool (J-24394). Remove spark plug wires and accelerator linkage springs. Remove intake manifold and carburetor as an assembly.

Installation — Install new intake manifold gaskets and position new rubber seals on front and rear rails on cylinder block. Make sure pointed end of rail seals tight against block and head. Apply RTV sealer or equivalent to end of seals. Install intake manifold and tighten bolts in sequence shown in illustration. To complete installation, reverse removal procedure.

CYLINDER HEAD

NOTE — Depending on vehicle model and cylinder head being removed, removal procedures will vary.

The following procedures apply to right cylinder head for all models:

Removal — Remove intake manifold as previously outlined. Remove drive belts, disconnect wires from alternator and remove alternator. Remove air conditioning compressor (if equipped) from mount without disconnecting lines and position out of way. Disconnect spark plug wires from spark plugs. Remove exhaust manifold retaining bolts. Remove valve cover, rocker arm assembly and push rods. Mark push rods to ensure that they are installed in original position. Remove cylinder head.

The following procedures apply to left cylinder head for Buick Skyhawk, Century and Regal, and Oldsmobile Starfire:

Removal — Remove intake manifold as previously outlined. Remove dip stick. Remove power steering pump and mount without disconnecting lines and position pump out of way. Disconnect spark plug wires from spark plugs. Remove exhaust manifold retaining bolts. Remove valve cover, rocker arm assembly and push rods. Mark push rods to ensure that they are installed in original position. Remove cylinder head.

The following procedures apply to left cylinder head for Buick Apollo:

Removal — 1) Remove intake manifold as previously outlined. Remove dip stick. Remove power steering pump and mount without disconnecting hoses and position out of way. Disconnect spark plug wires at spark plugs. Remove valve cover, rocker arm assembly and push rods. Mark or position push rods to ensure that they are installed in original position.

231" V6 (Cont.)

2) Remove power brake hose at rear of cylinder head. Raise vehicle and place on safety stands. Disconnect exhaust crossover pipe and support. Remove left front engine mount bolt and loosen right front engine mount bolt. Raise engine with a hoist. Remove cylinder head bolts and remove cylinder head. If exhaust manifold does not clear steering gear, engine must be raised further.

quence shown in illustration. To complete installation, reverse removal procedure for individual vehicles.

Installation (All Models) — Make sure gasket surfaces on cylinder block and head are clean. Make sure cylinder head bolt holes in cylinder block and bolt threads are clean. Place new gasket on cylinder block and position head on cylinder block. Lubricate bolt threads, install bolts and tighten in se-

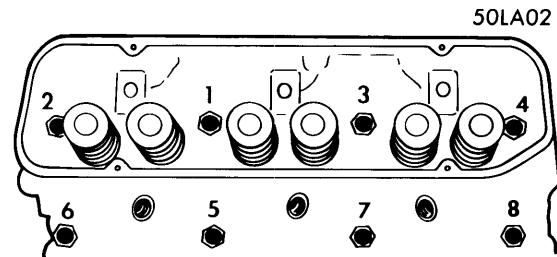

CYLINDER HEAD TIGHTENING SEQUENCE

VALVES							
Engine & Valve	Head Diam.	Face Angle	Seat Angle	Seat Width	Stem Diameter	Stem Clearance	Valve Lift
231" Int.	1.620-1.630"	45°	45°	.063"	.3405-.3412"	.0015-.0032"
Exh.	1.420-1.430"	45°	45°	.094"	.3405-.3412"	.0015-.0032"

VALVE ARRANGEMENT

E-I-E-I-I-E (Left side, front to rear.)
E-I-I-E-I-E (Right side, front to rear.)

retainer and spring. Remove valve stem oil seal from intake valves.

VALVE GUIDE SERVICING

If valve stem to guide clearance exceeds specifications, valve guide must be reamed and a valve with a .010" oversize valve stem installed. Ream guide with a .006" oversize reamer and then a .010" oversize reamer. A valve with a .006" oversize valve stem may be installed at factory. Oversize valves are identified by an oversize marking on valve head.

Installation — Check valve springs in a suitable valve spring tester and replace as necessary. Install valve stem oil seals on intake valves. To install springs, reverse removal procedure.

VALVE STEM INSTALLED HEIGHT

Measure height of valve stem tip above valve spring seat. Specified height is 1.933". If specified height is over .050" above specification, valve must be replaced or an appropriate amount of valve stem tip ground off.

VALVE STEM OIL SEALS

Valve stem oil seals are installed on intake valves only. Seal is mounted on valve guide. A new seal should be installed whenever valve spring is removed. To install new seals, carefully slide seal over valve stem and push down until it contacts valve guide. Using a suitable tool (J-22509) push seal onto guide until seal bottoms against guide.

ROCKER ARM ASSEMBLY

With rocker arm assembly removed, remove nylon rocker arm retainers and remove rocker arms from shaft. Inspect shaft and rocker arms for wear, scoring or damage. Replace components as necessary. If rocker arms are being replaced, note that rocker arms are marked left and right. Reverse disassembly procedure to assemble rocker arms. Rocker arms must be installed in correct order on shafts (see illustration) and new nylon retainers installed.

VALVE SPRINGS			
Engine	Free Length	PRESSURE (LBS.)	
		Valve Closed	Valve Open
231"	56-69@1.73"	162-174@1.33"

HYDRAULIC VALVE LIFTER ASSEMBLY

If hydraulic valve lifters are being removed, mark or identify lifters to ensure that they are installed in original position. Lifters are serviced as complete assemblies only. If lifter is damaged or worn, complete lifter must be replaced. If lifters are disassembled for cleaning and inspection, after reassembly they should be tested using a suitable leak-down rate tester.

VALVE SPRINGS

Removal — With cylinder head removed, compress valve spring with a suitable spring compressor and remove valve keepers. Release spring compressor and remove spring

General Motors V6 Engines

231" V6 (Cont.)

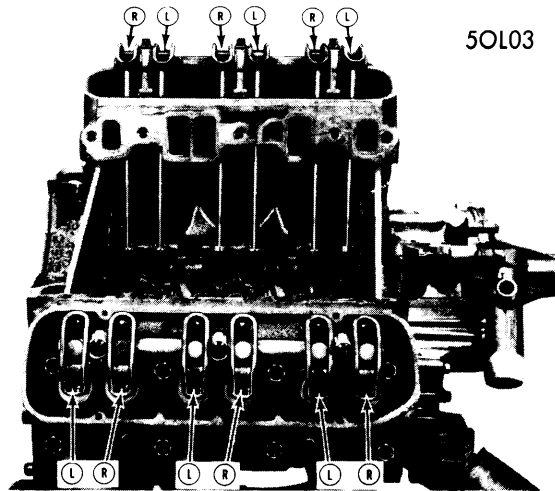

ROCKER ARM INSTALLED POSITION

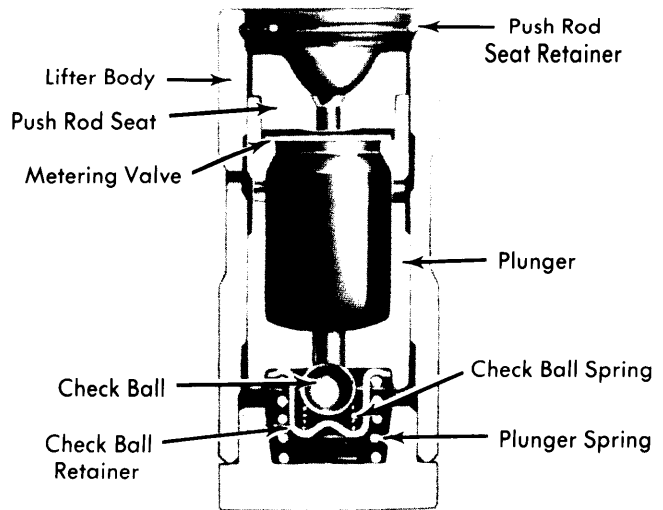

HYDRAULIC VALVE LIFTER ASSEMBLY

PISTONS, PINS, RINGS						
Engine	PISTONS	PINS		RINGS		
	① Clearance	Piston Fit	Rod Fit	Rings	End Gap	Side Clearance
231"	.0013-.0035"	.0004-.0007"	② .0007-.0017"	1	.010-.020"	.003-.005"
				2	.010-.020"	.003-.005"
				3	.015-.035"	.0001-.0035"

- ① — Measured at bottom of piston skirt.
- ② — Interference fit.

OIL PAN

See *Oil Pan Removal* at end of ENGINE Section.

PISTON & ROD ASSEMBLY

Removal — With cylinder heads removed, check top of cylinder bore for a ridge. Remove ridge using a suitable ridge reamer. Mark or identify pistons to cylinders to ensure that they are installed in original position. With oil pan removed, rotate engine until number one rod is straight down. Remove rod nuts and caps. Install suitable guide on rod bolts and push piston and rod assembly out of cylinder bore. Follow same procedure to remove remaining piston and rod assemblies.

Installation — Position rings in piston as shown in illustration. Make sure cylinder bore, pistons and bearing journals are clean. Coat bearing surfaces and cylinder bore with oil. Rotate crankshaft until rod journal of piston and rod assembly being installed is straight down. Place bearing insert in rod and install guides on rod bolts. Compress piston rings using a suitable ring compressor. Position piston in bore so that notch in top of piston is facing toward front of engine. Push piston into bore, carefully guiding rod over crankshaft until bearing is seated against journal. Remove guides and install rod cap and bearing. Tighten rod nuts.

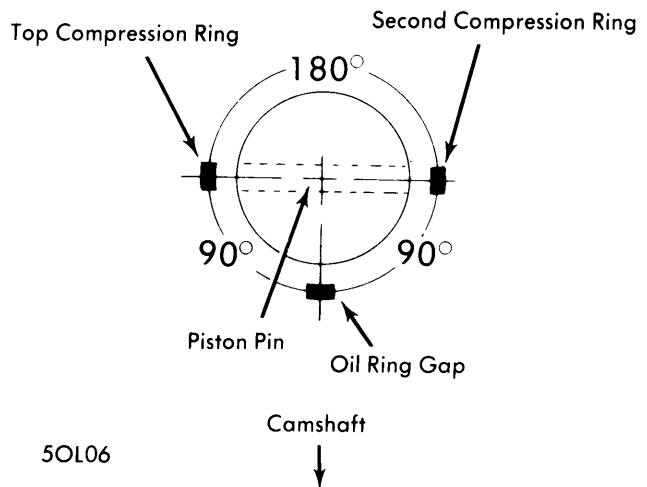

PISTON RING GAP POSITIONS

FITTING PISTONS

With piston and rod assembly removed, thoroughly clean cylinder bore. Inspect bore for scoring or grooves. Measure

231" V6 (Cont.)

cylinder bore for taper or out-of-round. If cylinder tapers more than .005" or is out-of-round more than .003", cylinder must be bored and oversize pistons and rings installed. Measure piston diameter at right angle to piston pin and 1/4" below oil ring groove. If clearance between piston and cylinder is excessive, cylinder must be bored and oversize pistons and rings installed.

piston and connecting rod. Inspect pin for wear or scoring. Check clearance of pin in piston. If clearance is excessive, piston and pin assembly must be replaced. Place piston on rod in correct position depending on which bank piston and rod are being installed in (see illustration). Lubricate piston pin and press into piston and rod using a suitable tool and press.

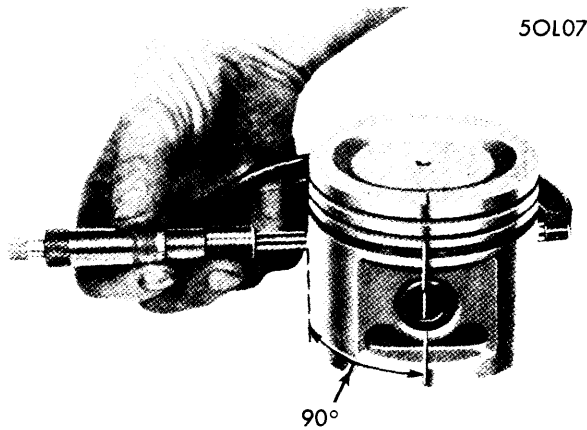

MEASURING PISTON DIAMETER

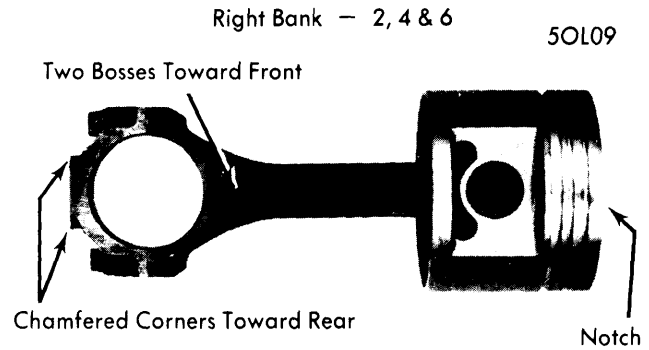

RIGHT BANK PISTON & ROD ASSEMBLY

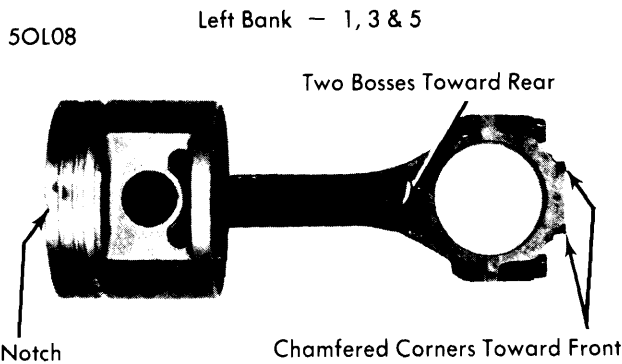

LEFT BANK PISTON & ROD ASSEMBLY

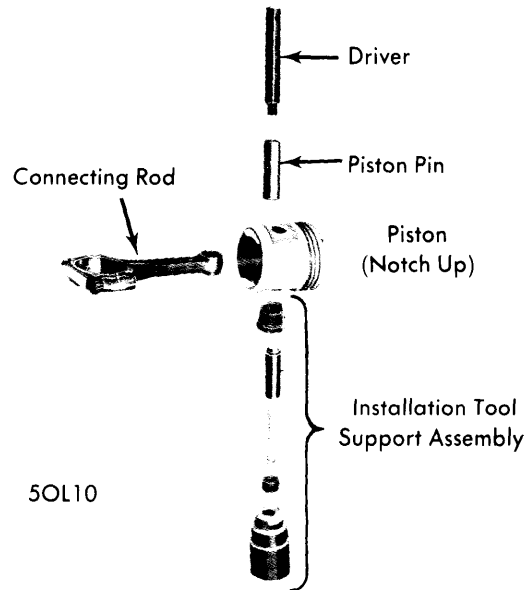

PISTON PIN INSTALLATION

PISTON PINS

Piston pin is selective press fit in connecting rod. Using a suitable tool set and a press, remove piston pin and separate

CRANKSHAFT MAIN & CONNECTING ROD BEARINGS

Engine	MAIN BEARINGS				CONNECTING ROD BEARINGS		
	Journal Diam.	Clearance	Thrust Bearing	Crankshaft End Play	Journal Diam.	Clearance	Side Play
231"	2.4995"	.0004-.0015"	No. 2	.004-.008"	2.0000"	.0005-.0026"	.006-.027"

MAIN & CONNECTING ROD BEARINGS

Connecting Rod Bearings - With rod cap removed, inspect bearings for flaking or wear. Check connecting rod journal for scoring or grooves. Measure rod journal with a

micrometer and check journal for out-of-round conditions. Journal should not exceed .0015" out-of-round. Check bearing to journal clearance using the Plastigage method. If clearance exceeds .003", a selective fit undersize bearing may be installed to obtain correct clearance. If clearance is still excessive, crankshaft must be replaced.

231" V6 (Cont.)

Main Bearings — With main bearing cap removed, inspect bearing for flaking or scoring. Inspect main bearing journal for wear or grooves. Check journal for out-of-round conditions with a micrometer. If journal is out-of-round more than .0015", crankshaft must be replaced. Check bearing to journal clearance using the Plastigage method. If clearance exceeds specifications, a selective fit undersize bearing may be installed to obtain correct clearance. If clearance is still excessive, crankshaft must be replaced.

REAR MAIN BEARING OIL SEAL

Upper half of seal can only be replaced if crankshaft is removed. A seal that leaks can be repaired without being replaced.

Oil Seal Repair — 1) With rear main bearing cap removed, insert a suitable packing tool (J-21526-2) against one end of seal in block. Pack seal in until tight, by driving in against seal with tool. Seal should be approximately 1/4" to 3/4" below edge of cylinder block. Repeat this procedure on both ends of seal. Measure amount that is packed into groove and add 1/16". Measure this total on seal removed from main bearing cap and cut off amount. Cut off amount for opposite side also.

2) Install a suitable guide tool (J-21526-1) on cylinder block. Using packing tool, drive cut off piece into groove until packing tool reaches stop on guide tool. Follow same procedure to pack cut off piece into opposite side. Install new seal into rear main bearing cap. Install rear main bearing cap.

Oil Seal Replacement — With crankshaft removed, pry old seals out of cylinder block and main bearing cap. Position new seal halves in grooves. Roll seals into grooves with a hammer handle. Continue rolling seal until ends protrude 1/16" above edge and cut off flush with a razor blade. Lubricate seal contact surface on crankshaft. Install crankshaft and main bearing cap.

Main Bearing Cap Side Seals — Neoprene seals are placed on sides of bearing cap. Seals are slightly undersize when newly installed (and may leak) since neoprene composition swells in presence of heat and oil. Seals are slightly longer than grooves in cap, but should not be cut off. Soak seals in light oil or kerosene for one or two minutes before installation. After seals are installed, force up into cap with end of hammer handle. Apply RTV sealer to mating surface of main bearing cap before installation.

THRUST BEARING ALIGNMENT

With thrust bearing cap bolts finger tight, move crankshaft forward and backward with last movement being forward. Tighten thrust bearing cap bolts.

FRONT ENGINE COVER

Removal — Drain cooling system and disconnect upper and lower radiator hoses and heater hose at water pump. Remove drive belts, fan and pulleys. Disconnect fuel lines and remove fuel pump. Remove alternator and mount, and distributor. If timing chain and sprockets are not being removed, note position of rotor on distributor for installation. Loosen front clamp on thermostat by-pass hose. Remove harmonic balancer. Remove front engine cover retaining bolts and remove cover.

Installation — Oil pump cover should be removed and petroleum jelly packed around oil pump gears whenever front engine cover is removed. Oil pump may lose its prime when front engine cover is removed. Make sure gasket surfaces are clean and use new gasket. Use sealer on bolt threads. Reverse removal procedure to install front engine cover.

FRONT COVER OIL SEAL

Removal — With front engine cover removed, drive seal out from front to rear of cover, using a drift punch.

Installation — Coil new packing around opening so that ends are at top. Using a suitable punch, drive in shedder and stake in place at three points. Size packing by rotating a hammer handle around packing until balancer hub can be inserted through opening.

CAMSHAFT			
Engine	Journal Diam.	Clearance	Lobe Lift
231"	1.785-1.786"	① .0005-.0025"	.2217"
		② .0005-.0035"	

① — Journal No. 1.

② — Remaining journals.

TIMING CHAIN

Removal — With front engine cover removed, rotate engine until timing marks on sprockets are aligned. Remove crankshaft oil slinger. Remove distributor drive gear and fuel pump eccentric bolt and washer, and slide off gear and eccentric. Pry off camshaft sprocket using two screwdrivers, and remove camshaft sprocket and chain. If necessary, remove crankshaft sprocket.

Installation — Install crankshaft sprocket if removed. Position chain on camshaft sprocket and install sprocket and chain, making sure timing marks are aligned on sprockets (see illustration). Reverse removal procedure to complete installation.

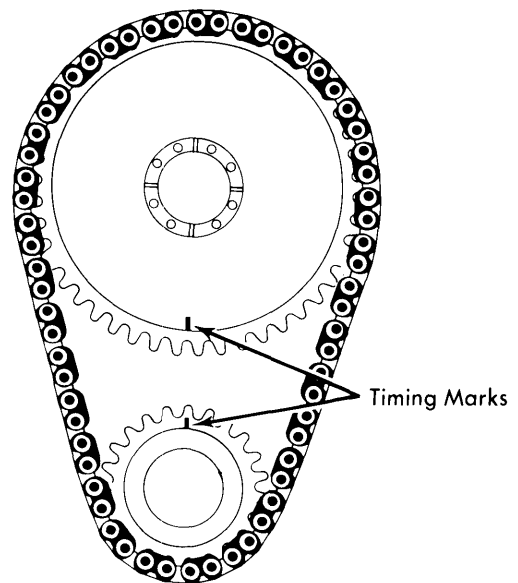

50LA11
TIMING CHAIN SPROCKET ALIGNMENT

CAMSHAFT

Removal — Remove intake manifold, rocker arm assemblies, push rods and lifters. Mark or identify push rods and lifters to ensure that they are installed in original position.

231" V6 (Cont.)

Remove front engine cover and timing chain and sprockets, as previously outlined. Remove radiator and shroud. Carefully slide camshaft out to avoid damaging camshaft bearings or lobes.

Installation — Thoroughly clean and inspect camshaft. Lubricate journals and camshaft lobes. Carefully insert camshaft taking care not to damage bearings or camshaft lobes. Reverse removal procedures to complete installation.

CAMSHAFT BEARINGS

Engine must be removed and crankshaft taken out to install new camshaft bearings. Slightly scored bearings will be satisfactory if bearings clean up easily and clearance with camshaft journals does not exceed specifications. Special remover and installer tools will be required to replace camshaft bearings in cylinder block. Align boring will not be required as precision replacement bearings are available.

ENGINE OILING

Crankcase Capacity — Capacity is four quarts, add one quart with filter change.

Oil Filter — Replace at first oil change and then every other oil change. Filter is spin-on disposable type.

Normal Oil Pressure — Oil pressure should be 37 psi at 2600 RPM.

Pressure Regulator Valve — Located in oil pump, nonadjustable.

ENGINE OILING SYSTEM

Lubrication is force-feed type. Oil is supplied under full pressure to crankshaft, connecting rods and camshaft bearings. Controlled volume of oil is supplied to valve lifters, push rods and rocker arms. Oil pump is located in front engine cover and receives oil from crankcase by a drilled passage to pickup pipe. Oil passes through full-flow oil filter, equipped with a by-pass valve, and to main oil galleries. Main oil galleries run full length of cylinder block and supply oil to valve lifters, camshaft bearings, main and connecting rod bearings. Pistons, cylinder walls, piston pins, distributor gears, timing chain and sprockets are lubricated by splash, gravity flow or squirt holes. Oil to rocker arms is pumped through tubular push rods.

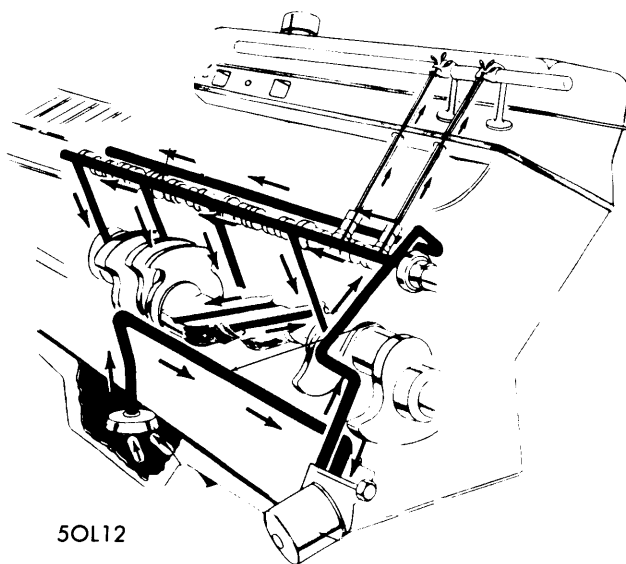

ENGINE OILING SYSTEM

OIL PUMP

Removal — Remove oil filter. Remove bolts securing oil pump cover assembly to front engine cover. Remove cover assembly and slide pump gears out of pocket. Remove pressure regulator plug, spring and valve from cover assembly.

Inspection — Thoroughly clean all components and inspect for wear or damage. Check fit of valve in bore. If clearance is excessive, replace valve and/or cover. Position gears in pocket in cover. Place a straight edge across gears and measure clearance between straight edge and gasket surface with a feeler gauge. Specified clearance is .002-.006". If clearance is less than .0018", check gear pocket for wear.

Assembly — Pack gear pocket with petroleum jelly and insert gears into pocket, making sure that jelly is packed into all pockets. Lubricate and install regulator valve in cover. Install spring, gasket and plug. Install new gasket and position cover on oil pump. Tighten cover retaining bolts.

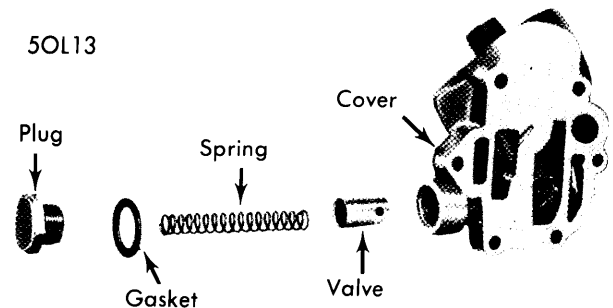

OIL PUMP COVER & COMPONENTS

TIGHTENING SPECIFICATIONS

Application	Ft. Lbs.
Cylinder Head	75
Connecting Rods	40
Main Bearing Caps	115
Harmonic Balancer Bolt	140
Flywheel or Torque Plate	55
Intake Manifold	45
Exhaust Manifold	25
Front Engine Cover	30
Fuel Pump Eccentric & Camshaft Sprocket Bolt	45
Rocker Arm Assembly	30
Pulley-to-Harmonic Balancer	20
Motor Mounts-to-Engine	55
Oil Pan	15
Oil Pump Cover	10