

302", 351" & 400" FORD & MERCURY V8

GENERAL SPECIFICATIONS						
Engine	Net HP At RPM	Torque (Ft. Lbs. at RPM)	Compr. Ratio	Bore	Stroke	Displ. Cu. Ins.
302" 2-Bbl.	4.00"	3.00"	302
351"W 2-Bbl.	4.00"	3.50"	351
351" M 2-Bbl.	4.00"	3.50"	351
400" 2-Bbl.	4.00"	4.00"	400

ENGINE IDENTIFICATION

Engine may be identified by the official Vehicle Identification Number. Number is stamped on metal tab fastened to instrument panel close to windshield on drivers side of car and visible from outside. The Identification number contains eleven digits. Example: 5HS63H100001. The first digit establishes model year and fifth digit engine identification.

Engine	Engine Code
302" 2-Bbl.	F
351"W 2-Bbl.	H
351" M 2-Bbl.	H
400" 2-Bbl.	S

NOTE — The new 351" M engine replaces the 351" C engine. The 351" M engine was created by reducing the stroke of 400" engine from 4.00" to 3.50". Camshaft and valve stem oil seals are the same as those used in 1974 351" C engines.

ENGINE REMOVAL

See Engine Removal at end of ENGINE Section.

INTAKE MANIFOLD

Removal — Drain cooling system. Remove air and intake duct assembly. Disconnect radiator upper hoses at engine, heater hoses at intake manifold and water pump. Disconnect all vacuum lines and electrical wires (remove distributor cap and wires as an assembly), then remove distributor. Disconnect and remove coil, fuel line, accelerator linkage, and Thermoactor bypass valve and hose. If vehicle is equipped with air conditioning, remove compressor to intake manifold brackets. Remove intake manifold and carburetor as an assembly (302" and 351"W only). Remove carburetor from manifold, then remove intake manifold assembly (351" M and 400" only).

Installation — Apply suitable oil resistant sealer at four junction points of seals and gaskets. Position front and rear seals

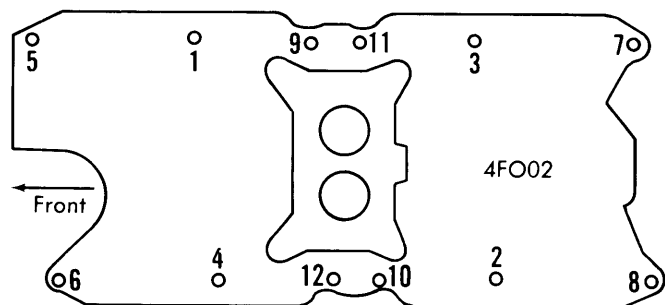

INTAKE MANIFOLD TIGHTENING SEQUENCE, 302"

on cylinder block and new gaskets on heads. Make sure that holes in gaskets are aligned with holes in cylinder head. Position gaskets so interlocked with seal tabs. Lower manifold on engine and check for correct positioning of gaskets and seals before installing bolts. Install bolts and tighten to specifications (see illustrations for sequence). Run engine until normal operating temperature is reached, then retorquing bolts.

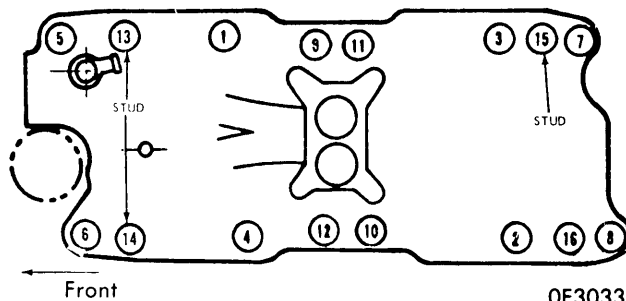

INTAKE MANIFOLD TIGHTENING SEQUENCE 351"W

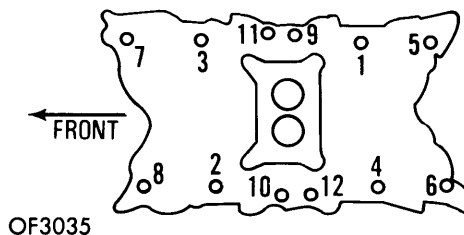

INTAKE MANIFOLD TIGHTENING SEQUENCE 351" M & 400"

CYLINDER HEAD

Removal — 1) Remove intake manifold and carburetors as an assembly. Remove rocker arm covers.

2) Disconnect A/C compressor and position to one side. Do not disconnect refrigerant lines. Disconnect power steering pump and bracket, remove drive belt from pump pulley and position to one side. Remove alternator mounting bracket bolt, air cleaner inlet duct and ignition coil.

3) Disconnect exhaust pipe at manifold. On some engines it may be necessary to remove exhaust manifold to gain access to lower cylinder head bolts. Remove push rods. On 302" engines, remove exhaust valve stem caps. Remove cylinder head.

Ford Motor Co. V8 Engines

302", 351" & 400" FORD & MERCURY V8 (Cont.)

Installation – Clean old gasket material from cylinder head and block. Position head gasket on block and install cylinder head. Install bolts and tighten in three steps to specification in sequence shown in illustration.

Cylinder Head Tightening Specifications

Engine	Ft. Lbs. Step 1	Ft. Lbs. Step 2	Ft. Lbs. Step 3
302" 2-Bbl.	50	60	65-72
351" W	85	95	105-112
351" M, 400"	55	75	95-105

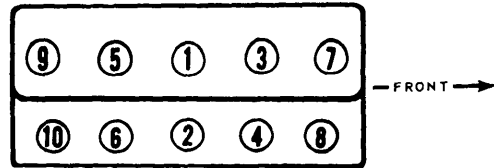

2F389

CYLINDER HEAD TIGHTENING SEQUENCE

VALVES								
Engine & Valve		Head Diam.	Face Angle	Seat Angle	Seat Width	Stem Diameter	Stem Clearance	Valve Lift
302"	Int.	1.782"	44°	45°	.060-.080"	.3416-.3423"	.001-.0027"	.3707"
	Exh.	1.451"	44°	45°	.060-.080"	.3411-.3418"	.0015-.0032"	.3823"
351" W	Int.	1.782"	44°	45°	.060-.080"	.3416-.3423"	.001-.0027"	.418"
	Exh.	1.451"	44°	45°	.060-.080"	.3411-.3418"	.0015-.0032"	.448"
351" M, 400"	Int.	2.041"	44°	45°	.060-.080"	.3416-.3423"	.001-.0027"	.406"ⓐ
	Exh.	1.655"	44°	45°	.070-.090"	.3411-.3418"	.0015-.0032"	.406"ⓐ

ⓐ – Valve lift on 400" engine is intake .427" and exhaust .433".

VALVE ARRANGEMENT

All Engines – E-I-E-I-E-I-E-I (Left bank, front to rear).
I-E-I-E-I-E-I-E (Right bank, front to rear).

VALVE GUIDE SERVICING

To ream guides for installation of valves with oversize stems, always use reamers in sequence and reface valve seat after valve guide is reamed. Reamers are furnished .003" oversize with standard diameter pilot; .015" oversize reamer with .003" oversize pilot; and .030" oversize reamer with .015" oversize pilot.

VALVE STEM OIL SEALS

Cup or umbrella type seals used on all valves. Install seals with cup side down over valve guide.

VALVE SPRINGS

Removal – 1) Remove rocker arm cover and spark plug on cylinder to be serviced. Install air line with adapter in spark plug hole. *NOTE* – If air pressure fails to hold valve closed, remove cylinder head for inspection of valve seat.

2) Remove required rocker arms and push rods. On 302" engines, remove exhaust valve stem caps. Use suitable spring compression tool to compress valve and remove retainer locks, sleeve (302" & 351"W only), spring retainer and valve spring. Remove and discard valve stem seal. Do not remove air pressure as this will allow valve to fall into cylinder if piston is at bottom of cylinder.

Installation – 1) Lubricate valve stem with engine oil and install new valve stem seal. Place spring in position over valve and install spring retainer and sleeve. Compress valve spring and install locks.

2) Apply Lubriplate to ends of push rods and tip of valve stem. Install exhaust valve stem caps on 302" engines. Install rocker arms and tighten.

VALVE SPRING INSTALLED HEIGHT

Spring ends must be square within $\frac{5}{64}$ ". Installed height of valve spring must not exceed specifications. Measure height from surface of cylinder head pad to underside of spring retainer. If height is greater than specified, install .030" spacer on head under spring to bring height within limits. **CAUTION** – Install spacers only if necessary and do not use more than two spacers (more than two will overstress springs and overload camshaft lobes).

VALVE SPRINGS			
Engine	Free Length	PRESSURE (LBS.)	
		Valve Closed	Valve Open
302" Int.	1.94"	76-84 @ 1.69"	190-210 @ 1.31"
	1.85"	76-84 @ 1.60"	190-210 @ 1.22"
351"W	2.07"	71-79 @ 1.79"	190-210 @ 1.34"
351" M	2.06"	76-84 @ 1.82"	215-237 @ 1.39"
400"	2.06"	76-84 @ 1.82"	215-237 @ 1.39"

302", 351" & 400" FORD & MERCURY V8 (Cont.)

Engine	Installed Height
302" Int.	1 ⁴³ / ₆₄ - 1 ⁴⁵ / ₆₄ "
Exh.	1 ¹⁹ / ₃₂ - 1 ³⁴ / ₆₄ "
351"W	1 ⁴⁹ / ₆₄ - 1 ¹³ / ₁₆ "
351" M & 400"	1 ¹³ / ₁₆ - 1 ²⁷ / ₃₂ "

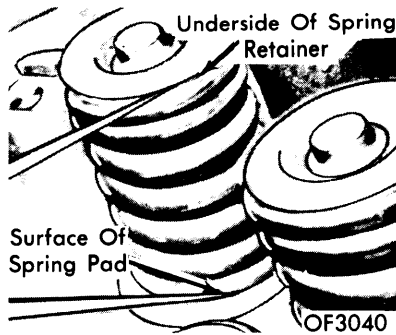

MEASURING VALVE SPRING INSTALLED HEIGHT

ROCKER ARM STUDS

302" & 351"W Engines - With suitable tool, remove old stud. Studs that are broken or have damaged threads may be replaced with standard studs. Studs are also available in .006", .010" and .015" oversizes. If necessary to install oversize stud, use reamers in sequence and finish ream to attain desired oversize. Special stud drivers are available for installation. When driver contacts stud boss, stud is installed to correct height.

HYDRAULIC VALVE LIFTER ASSEMBLY

Two different types of lifters may be used, (see illustrations). Lifters are serviced as assemblies only and parts are not interchangeable. Always check rocker arm-to-valve stem clearance before concluding a noisy lifter is defective. After cleaning and reassembling lifters, they should be tested for leak down rate. Use lifter tester according to directions of manufacturer. Leak down rate is 5-50 seconds measured at $\frac{1}{16}$ " plunger travel.

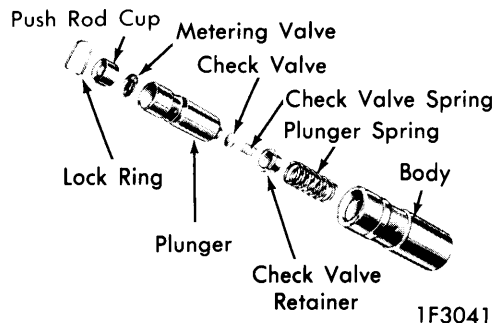

TYPE I LIFTER ASSEMBLY

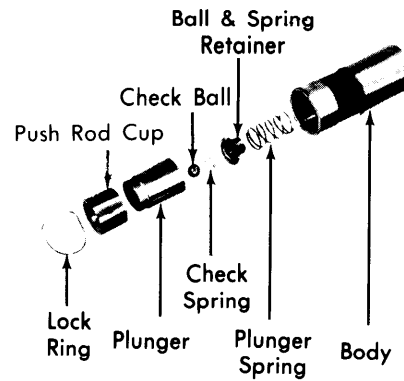

TYPE II LIFTER ASSEMBLY

HYDRAULIC VALVE LIFTER ADJUSTMENT

Repeated valve (seat and face) reconditioning operations will decrease valve stem to rocker arm clearance to point that if compensation is not made, valve lifters will cease to function. To compensate for any dimensional changes in valve mechanism, a .060" shorter or a .060" longer replacement push rod is available. To determine whether or not a longer or shorter push rod is necessary, clearance between rocker arm and valve stem must be checked. **NOTE** - Valve lifter must be completely collapsed when checking valve clearance. Use suitable tool and slowly collapse valve lifter until plunger is bottomed. Hold lifter down while checking clearance. Procedure for checking valve clearances is as follows:

- 1) Rotate crankshaft until No. 1 piston is at TDC (point "A", see illustration) after compression stroke as indicated by timing mark on crankshaft damper and pointer. Make a chalk mark on damper 180° (point "B") from TDC mark. Make a chalk mark on damper 90° (point "C") counterclockwise from TDC mark.

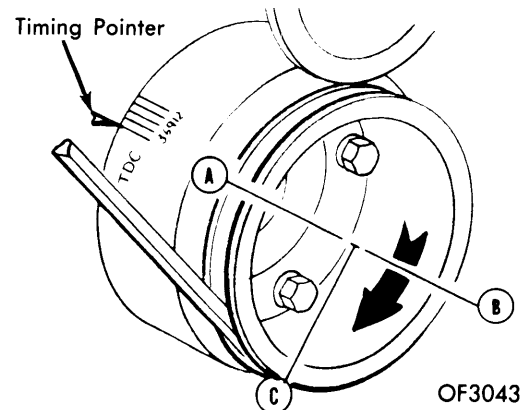

POSITIONS FOR CHECKING VALVE CLEARANCE

- 2) With damper at point "A", check following valve clearances with specifications:

Ford Motor Co. V8 Engines

302", 351" & 400" FORD & MERCURY V8 (Cont.)

302" - Intake No. 1,7,8. Exhaust No. 1,5,4.

All Other Engines - Intake No. 1,4,8. Exhaust No. 1,3,7.

3) Rotate crankshaft 180° clockwise from point "A" so that point "B" is opposite pointer. Check following valve clearances:

302" - Intake No. 4,5. Exhaust No. 2,6.

All Others Engines - Intake No. 3,7. Exhaust No. 2,6.

4) Rotate crankshaft 270° clockwise from point "B" so point "C" is opposite pointer. Check following valve clearances:

302" - Intake No. 2,3,6. Exhaust No. 7,3,8.

All Other Engines - Intake No. 2,5,6. Exhaust No. 4,5,8.

Hydraulic Valve Lifter Clearance

302"090-.140"
351"W106-.156"
351" M & 400"100-.150"

PISTONS, PINS, RINGS						
Engine	PISTONS	PINS		RINGS		
	Ⓢ Clearance	Piston Fit	Rod Fit	Ring	End Gap	Side Clearance
302'	.0018-.0026"	.0002-.0004"	Press Fit	Comp. Oil	.010-.020" .015-.055"	.002-.004" Snug
351"W	.0018-.0026"	.0003-.0005"	Press Fit	Comp. Oil	.010-.020" .015-.055"	.002-.004" Snug
351" M, 400"	.0014-.0022"	.0002-.0004"	Press Fit	Comp. Oil	.010-.020" .015-.055"	.002-.004" Snug

Ⓢ Measured at piston pin bore centerline, 90° to pin bore.

OIL PAN

See Oil Pan Removal at end of ENGINE Section.

hammer handle to seat connecting rod against crankshaft. Install rod caps and tighten.

PISTON & ROD ASSEMBLY

NOTE - New pistons must be installed in same cylinders for which they were fitted and used pistons in same cylinder from which they were removed.

Removal - With cylinder head and oil pan removed, use a suitable ridge cutter to remove any ridge or deposits on upper end of cylinder bore. **NOTE** - Piston must be at bottom of stroke and covered with cloth to collect cuttings. Inspect connecting rods and caps for cylinder identification and mark as necessary. Remove rod cap and push piston and rod assembly out top of cylinder block taking care not to nick crankshaft journal or cylinder wall.

Installation - Lightly coat cylinder bores, pistons and rings with engine oil. Ensure that ring gaps are properly spaced (see illustration) and install ring compressor on piston. Install each piston and rod assembly (with notch on piston head facing front of engine) in its respective bore and guide connecting rod onto crankshaft journal while tapping piston head with

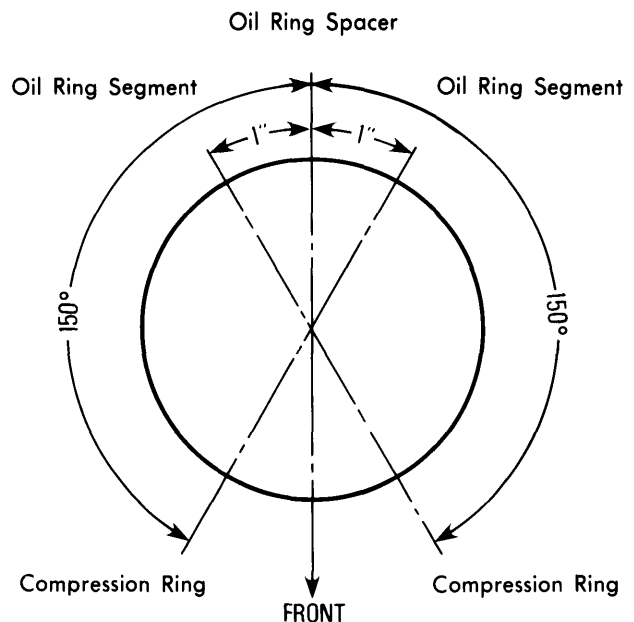

PISTON RING GAP SPACING

4FO011

302", 351" & 400" FORD & MERCURY V8 (Cont.)

FITTING PISTONS

Measure piston at centerline of piston pin bore 90° to pin bore axis. Measure cylinder bore at right angles to centerline of crankshaft, below ring travel. Piston clearance should be within specifications.

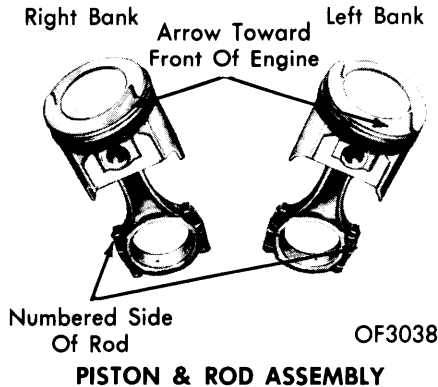

PISTON PINS

Piston pins are replaced using arbor press and suitable pilots and drivers (see illustration). Pins are a press fit in bore.

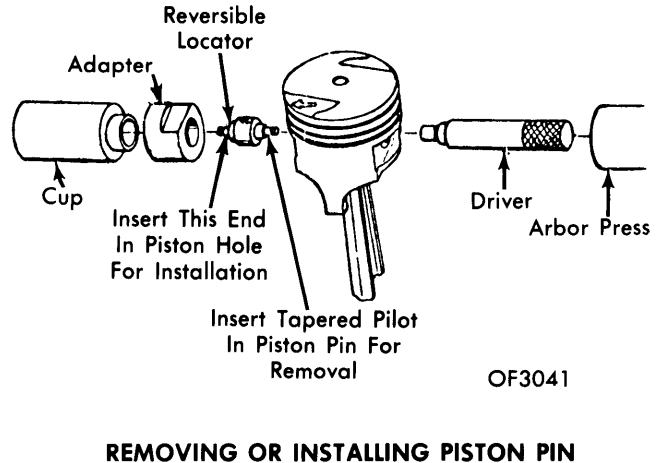

CRANKSHAFT MAIN & CONNECTING ROD BEARINGS							
Engine	MAIN BEARINGS				CONNECTING ROD BEARINGS		
	Journal Diam.	Clearance	Thrust Bearing	Crankshaft Endplay	Journal Diam.	Clearance	Sideplay
302"	2.2482-2.2490"	.0001-.0005"①	No. 3	.004-.008"	2.1228-2.1236"	.0008-.0015"	.010-.020"
351"W	2.9994-3.0002"	.0008-.0015"	No. 3	.004-.008"	2.3103-2.3111"	.0008-.0015"	.010-.020"
351" M, 400"	2.9994-2.3002"	.0010-.0015"	No. 3	.004-.008"	2.3103-2.3111"	.0011-.0015"	.010-.020"

① — No. 1 Bearing only, all others are .0005-.0015".

MAIN & CONNECTING ROD BEARINGS

NOTE — Following procedures are with oil pan removed.

Removal — Remove connecting rod cap after ensuring caps are marked for identification to rod assembly. Use suitable tool (6331) in oil hole of crankshaft to remove upper half of main bearing by rotating crankshaft in direction of engine rotation. Replace main bearings one at a time.

Installation — Determine crankshaft journal clearance in bearing using Plastigage method. Place a jack under counterweight adjoining bearing being checked so weight of crankshaft will not compress Plastigage and provide an erroneous reading. If bearing clearance is excessive, a .001" or .002" undersize bearing may be used in combination with a standard size bearing. If .002" undersize bearings are used on more than one journal, they may be positioned in cylinder block rather than bearing cap. If standard and .002" undersize combination do not bring bearing clearance within specified limits, crankshaft will have to be refinished and undersized bearings installed.

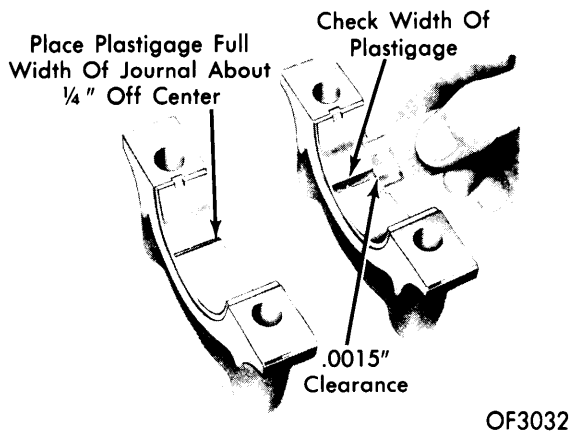

THRUST BEARING ALIGNMENT

Install all bearing caps except thrust bearing cap and tighten. Install thrust bearing cap with bolts finger tight. Pry crankshaft to front of engine, then pry thrust cap to rear of engine. While holding crankshaft forward, tighten bearing cap bolts. Check crankshaft endplay.

REAR MAIN BEARING OIL SEAL

Complete seal is replaced without removing crankshaft as follows:

1) Loosen all main bearing bolts, lowering crankshaft not to exceed 1/32". Remove rear main bearing cap, remove seal half from cap. Remove upper seal half with suitable tool, being careful not to scratch or damage crankshaft journal or seal surfaces.

302", 351" & 400" FORD & MERCURY V8 (Cont.)

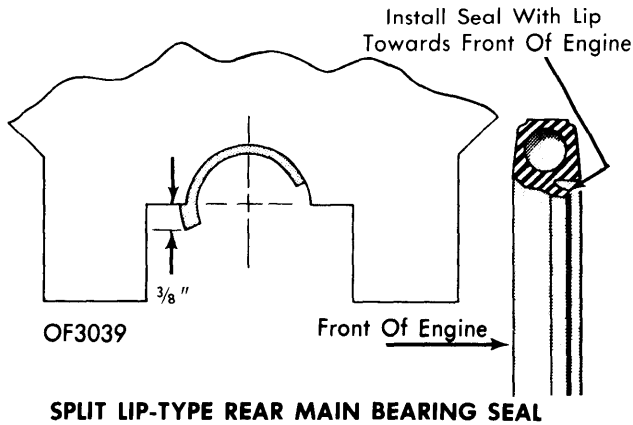

2) Remove oil seal retaining pin from bearing cap (if equipped). Discard pin. Dip seal halves in engine oil. Install upper seal in groove with undercut side of seal toward front of engine, by rotating it on seal journal until $\frac{3}{8}$ " protrudes below parting surface (see illustration). Tighten main bearing cap bolts.

3) Install lower seal in rear bearing cap with undercut side towards front of engine, allowing seal to protrude $\frac{3}{8}$ " above parting surface.

4) Apply thin coating of oil resistant sealer to cap at rear of top mating surface. **NOTE** — Do not apply sealer to area forward of side seal groove. Install main bearing cap and tighten bolts.

ENGINE FRONT COVER

Removal — Drain cooling system and crankcase. Remove fan, spacer and all hoses or brackets attaching to water pump. Remove crankshaft pulley, and use suitable puller to remove vibration damper. Disconnect fuel pump outlet line from fuel pump, remove fuel pump bolts and lay pump to one side. Remove front cover bolts and cut oil pan gasket flush with cylinder block. Remove front cover and water pump as an assembly.

Installation — Clean all gasket surfaces. Use suitable sealer and install gaskets and seals. Use suitable pilot tool to center front cover on crankshaft, install bolts and tighten.

FRONT COVER OIL SEAL**302" & 351"W**

Removal — Remove front cover. Using suitable pin punch, drive out old seal.

Installation — Coat seal with grease and drive into cover using suitable tool (No. T58P-6700-B). Check seal to make sure that it has fully seated and the spring is positioned properly.

351" M & 400"

Removal — Install suitable seal puller tool (No. T70P-6B070-B), and tighten through bolts to position seal puller under seal flange. Alternately tighten four puller bolts to remove oil seal.

Installation — Coat seal with grease and press into front cover using suitable tool (No. T70P-6B070-A). Check seal to make sure that seal has fully seated.

CAMSHAFT			
Engine	Journal Diam.	③ Clearance ①	Lobe Lift ②
302"	2.0805-2.0815"	.001-.003"	Int. .2303" Exh. .2375"
	2.0655-2.0665"		
	2.0505-2.0515"		
	2.0355-2.0365"		
	2.0205-2.0215"		
351"W	Same as 302"	.001-.003"	Int. .260" Exh. .278"
351" M	2.1238-2.1248"	.001-.003"	Int. .235" Exh. .235"
	2.0655-2.0665"		
	2.0505-2.0515"		
	2.0355-2.0365"		
	2.0205-2.0215"		
400"	Same as 351" M	.001-.003"	Int. .247" Exh. .250"

① — Wear limit is .006"

② — Max. allowable lobe lift loss is .005"

③ — Allowable end play is .001-.007" on 302" and 351" W engines and .001-.006" on 351" M and 400" engines.

TIMING CHAIN

Inspection — With front cover removed, remove crankshaft front oil slinger. Rotate crankshaft in counterclockwise direction to take up slack on left side of chain. Establish reference point on block (left side of chain) and measure distance to chain. Rotate crankshaft clockwise to take up slack on right side of chain. Force left side of chain out with fingers and measure distance between reference point and chain. Deflection is difference between two measurements. If deflection exceeds .500", replace timing chain and sprockets.

Removal & Installation — Crank engine until timing marks are positioned properly (see illustration). Remove camshaft sprocket cap screw, washers and fuel pump eccentric. Slide both sprockets and timing chain forward and remove them as an assembly. To install, position timing chain on sprockets with timing marks aligned (see illustration). Slide sprockets and timing chain onto engine as an assembly. Install fuel pump eccen-

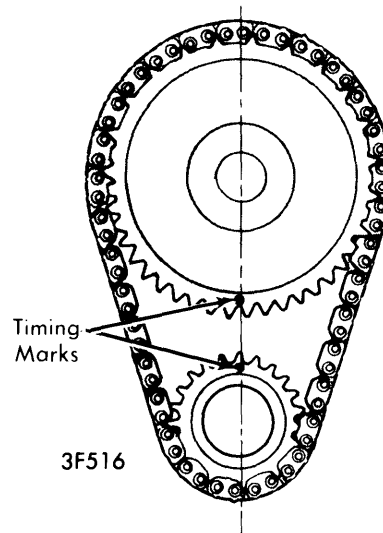
**TIMING CHAIN SPROCKET ALIGNMENT**

302", 351" & 400" FORD & MERCURY V8 (Cont.)

tric, washers and sprocket cap screw. Tighten bolt and oil timing chain.

CAMSHAFT

Removal – 1) Drain cooling system and remove radiator. Remove engine front cover, fuel pump and timing chain.

2) Remove intake manifold. Loosen rocker arms and remove pushrods. Remove valve lifters.

3) On 351" M and 400" engine, make sure No. 1 piston is in TDC position. Remove thrust plate and carefully pull camshaft towards front of engine and remove.

Installation – Oil camshaft journal with engine oil and apply Lubriplate to camshaft lobes. Carefully slide camshaft through bearings and install camshaft thrust plate.

CAMSHAFT BEARINGS

Removal & Installation – With camshaft, flywheel and crankshaft removed from engine, push pistons to top of cylinders. Remove camshaft rear bearing bore plug. Using suitable driver-puller tool, remove bearings. When installing new bearings, oil holes must be aligned. Front bearing must be installed specified distance below front face of cylinder block.

Front Bearing Installation

302", 351"W005-.020"
351" M, 400"040-.060"

CAMSHAFT END THRUST

Rocker arm stud nuts or bolts must be loosened sufficiently to free camshaft. Push camshaft toward rear of engine and install dial indicator so point is on camshaft sprocket attaching bolt, then zero indicator. Position screwdriver between camshaft sprocket or gear and block, pull camshaft forward and release. If end play is excessive, replace thrust plate. **CAUTION** – Do not attempt to pry camshaft back and forth with valve train load on camshaft.

CAM LOBE LIFT

Check lift of each camshaft lobe in consecutive order as follows:

1) Remove rocker arms and make sure each push rod is in valve lifter socket. Install dial indicator so ball socket adapter of indicator rests on end of push rod and in same plane as push rod movement.

2) With an auxiliary starter switch connected to starter solenoid and ignition switch off, bump crankshaft until tappet is on base circle of camshaft lobe. This is push rods lowest point.

3) Zero dial indicator and continue to rotate crankshaft until push rod is in fully raised position (highest indicator reading). Compare total lift from indicator readings with specifications.

4) To check accuracy of dial indicator readings, continue to rotate crankshaft until indicator reads zero. If lift on any lobe is .005" less than specifications, valve lifters are operating on worn lobes.

ENGINE OILING

Crankcase Capacity – 3½ qts., add ½ qt. with filter change (351" W & 302"), 4 qts., add 1 qt. with filter change (351" M & 400").

Oil Filter – Replace at first oil change and every second oil change after that.

Normal Oil Pressure (Hot at 2000 RPM) – 302" 40-60 psi, 351" W 40-65 psi, 351" M and 400" 45-75 psi.

Pressure Regulator Valve – In pump body. Not adjustable.

ENGINE OILING SYSTEM

Force feed with rotor type oil pump. All oil from pump flows through full flow oil filter before entering engine. From oil filter oil flows to main oil gallery located on right side of camshaft and lubricates engine components as follows:

Main Bearings – Oil from main gallery enters main bearings through drilled passages in block.

Camshaft Bearings – Passages are drilled from each main bearing to each camshaft bearing.

Timing Chain – Oil is forced through a drilled passage from oil pump intermediate shaft to groove in thrust plate and passes around camshaft. It then flows through two grooves in timing chain sprocket and is deflected onto the timing chain.

Connecting Rod Bearings – Crankshaft is drilled from main bearings to connecting rod bearings.

Valve Lifters, Push Rods – Oil passages drilled from main oil gallery to each lifter gallery. Oil hole in valve lifter is indexed to lifter oil gallery and oil flows into lifter. Oil from lifter is metered through disc metering valve and flows up hollow push rod. Drilled hole in push rod is indexed to hole in rocker arm and oil lubricates the upper valve train and bearings. Excess oil is returned to oil pan through drain back holes at each end of cylinder head and block.

OIL PUMP

Disassembly – Remove oil inlet tube, cover bolts and cover from pump. Remove inner rotor and shaft assembly, then remove outer race. Drill a small hole and insert self-threading sheet metal screw into oil pressure relief valve cap and pull cap from chamber. Remove spring and plunger.

Reassembly – Clean, inspect (see specifications) and oil all parts thoroughly. Install relief valve plunger, spring and new cap. Install outer race and inner rotor and shaft assembly. **NOTE** – Identification mark (dimple) on outer race must face outward and on same side as identification mark on rotor. Rotor and shaft assembly, and outer race are serviced as an assembly and one part cannot be replaced without replacing other part. Install cover and tighten bolts. Install oil inlet tube on pump.

Ford Motor Co. V8 Engines

302", 351" & 400" FORD & MERCURY V8 (Cont.)

ENGINE OILING (Cont.)

Oil Pump Specifications (All Engines)

Application	Clearance
Outer Race-to-Housing.....	.001-.013"
Rotor End Play001-.004"
Shaft-to-Housing0015-.0029"
Relief Valve-to-Bore0015-.0029"

Relief Valve Spring Specifications

Engine	Lbs. Pressure	Length
302"	10.6-12.2	1.704"
351"W	18.2-20.2	2.490"
351" M, 400"	20.6-22.6	2.490"

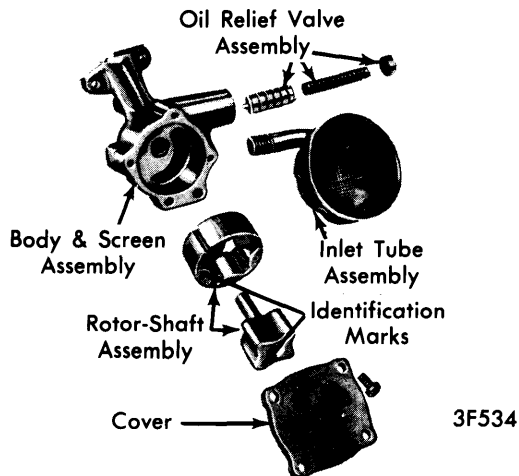

OIL PUMP ASSEMBLY (TYPICAL)

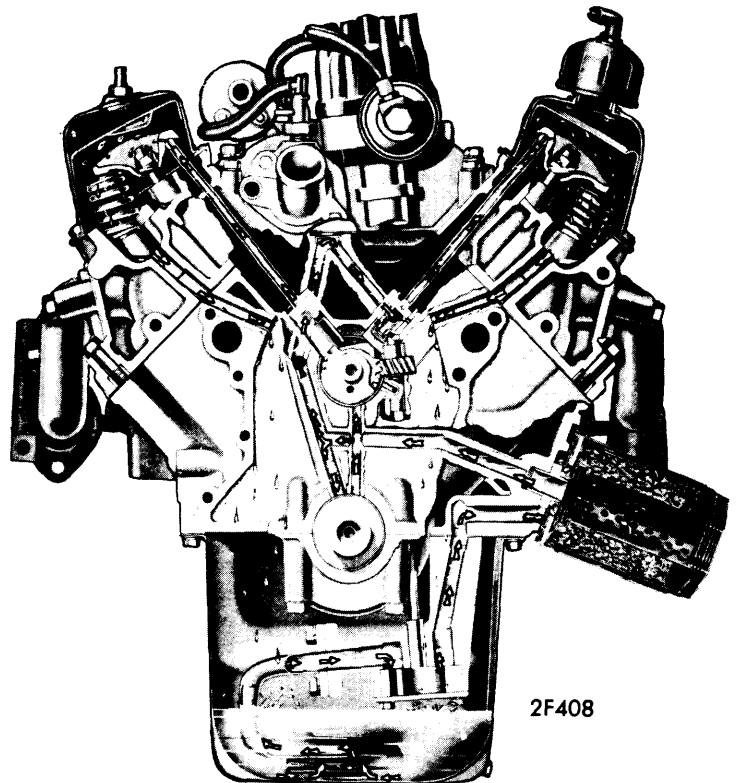

ENGINE OILING SYSTEM 302" & 351"W

TIGHTENING SPECIFICATIONS

Application	302"	351"W	351" M, 400"
Cylinder Head	① 65-72	① 105-112	① 95-105
Oil Pan	② 9-11	② 9-11	② 11-13
Intake Manifold	19-27	19-27	③ 25
Exhaust Manifold	12-16	18-24	12-16
Flywheel	75-85	75-85	75-85
Main Bearing Caps.....	60-70	95-105	④ 95-105
Connecting Rod Caps	19-24	40-45	40-45
Pulley-to-Damper	35-50	35-50	35-50
Rocker Arm Stud Nut.....	17-23	17-23
Engine Front Cover	12-15	12-15	14-20
Camshaft Sprocket	40-45	40-45	40-45
Oil Pump Cover	6-9	6-9	9-12
Rocker Arm Bolts	18-25
Damper-to-Crankshaft	70-90	100-130	70-90

① - See "Cylinder Head Installation".
 ② - 1/4" Bolts 7-9.
 ③ - 3/8" bolts 22-32 & 1/4" bolts 6-9.
 ④ - 3/8" bolts are 35-45 ft. lbs.