

# American Motors V8 Engines

## 304", 360" & 401"

GENERAL SPECIFICATIONS						
Engine	Net HP At RPM	Torque (Ft. Lbs. at RPM)	Compr. Ratio	Bore	Stroke	Displ. Cu. Ins.
304" 2-Bbl.	150 @ 4200	245 @ 2500	8.4-1	3.75"	3.44"	304
360" 2-Bbl.	175 @ 4000	285 @ 2400	8.25-1	4.08"	3.44"	360
360" 4-Bbl.	195 @ 4400	295 @ 2900	8.25-1	4.08"	3.44"	360
360" 4-Bbl. ①	220 @ 4400	315 @ 3100	8.25-1	4.08"	3.44"	360
401" 4-Bbl.	255 @ 4600	345 @ 3300	8.25-1	4.17"	3.68"	401

① - Dual Exhaust

► **NET HORSEPOWER & TORQUE NOTE** - Horsepower and Torque figures given above are NET. Net Horsepower and Torque represents power at the flywheel when the engine is installed in a vehicle, with wide open throttle and all systems operating such as; air cleaner, exhaust system, water pump, generator, oil pump and air conditioning.

### ENGINE IDENTIFICATION

Engine code number located on tag attached to valve cover, right bank. Letter contained in code number designates CID, carburetor, and compression ratio. Coding is as follows:

Code	CID	Carb.	Comp. Ratio
H.....	304.....	2-Bbl.....	8.4-1
N.....	360.....	2-Bbl.....	8.25-1
P.....	360.....	4-Bbl.....	8.25-1
Z.....	401.....	4-Bbl.....	8.25-1

### SPECIAL ENGINE MARKINGS

Some engines are produced at factory with oversize or undersize components. If following letters found stamped adjacent to engine code number, indicate following deviation from standard specifications:

- B** - All cylinder bores .010" oversize.
- M** - All main bearings .010" undersize.
- P** - All connecting rod bearings .010" undersize.
- PM** - All connecting rod and main bearings .010" undersize.
- C** - All camshaft bearing bores .010" oversize.

### ENGINE REMOVAL

See Engine Removal at end of ENGINE Section.

### INTAKE MANIFOLD

**Removal** - Drain cooling system and remove air cleaner. Disconnect spark plug wires, upper radiator hose and bypass hose from manifold, ignition coil bracket and position to one side. Remove TCS solenoid vacuum valve and solenoid control switch. Disconnect all hoses, lines, linkage and wires from carburetor and intake manifold. Disconnect air delivery hoses at air injection manifold and diverter valve from air pump output hose. Remove carburetor. Remove intake manifold, metal gasket and end seals.

**Installation** - Clean all mating surfaces and apply suitable sealing compound to both sides of new manifold gasket. Position gasket by aligning two rear locators at rear of cylinder head, then while holding rear in place, align two front locators. Install two end seals and apply sealing compound to seal ends. Install intake manifold, retaining bolts and tighten bolts.

### CYLINDER HEAD

**Removal** - Drain cooling system and remove rocker arm cover, rocker arm assemblies and push rods, spark plugs, intake manifold and exhaust manifold. **NOTE** - Keep rocker arm assemblies and push rods in same order as removed. Loosen all drive belts and remove compressor mount bracket and battery negative cable from cylinder head. Disconnect alternator support brace, air pump, and power steering pump mount bracket from cylinder head. Remove cylinder head retaining bolts. Remove cylinder head and gasket.

**Installation** - Clean all gasket surfaces. Apply thin coat of suitable sealing compound to both sides of head gaskets. **NOTE** - Do not apply sealing compound on head and block surfaces or allow sealer to enter cylinder bores. Position gasket on block with stamped word "TOP" facing up. Install cylinder head and retaining bolts. Tighten bolts in sequence (see illustration).

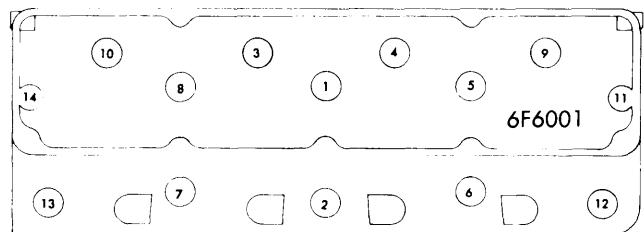

CYLINDER HEAD TIGHTENING SEQUENCE

VALVES								
Engine & Valve	Head Diam.	Face Angle	Seat Angle	Seat Width	Stem Diameter	Stem Clearance	Valve Lift	
304"	Int.	1.787"	29°	30°	.040-.060"	.3715-.3725"	.001-.003"	.....
	Exh.	1.406"	44°	44.5°	.040-.060"	.3715-.3725"	.001-.003"	.....
360"	Int.	2.025"	29°	30°	.040-.060"	.3715-.3725"	.001-.003"	.....
	Exh.	1.680"	44°	44.5°	.040-.060"	.3715-.3725"	.001-.003"	.....
401"	Int.	2.025"	29°	30°	.040-.060"	.3715-.3725"	.001-.003"	.....
	Exh.	1.680"	44°	44.5°	.040-.060"	.3715-.3725"	.001-.003"	.....

## 304", 360" & 401" (Cont.)

### VALVE ARRANGEMENT

All — E-I-I-E-E-I-I-E (front to rear, both banks).

### VALVE GUIDE SERVICING

Guides are integral part of cylinder head. If valve stem clearance becomes excessive due to guide wear, guides must be reamed to next oversize, and oversize valves installed. Oversize valves are available in .003", .015" and .030" oversize. Valve guide reamers are available for these oversizes. **NOTE** — Guides must be reamed in steps, starting with .003" oversize reamer and progressing to size desired.

### VALVE STEM OIL SEALS

Nylon valve stem seals are used on each valve stem and should be replaced whenever seals become deteriorated or valve service is performed.

VALVE SPRINGS			
Engine	Free Length	PRESSURE (LBS.)	
		Valve Closed	Valve Open
All Engines	2.20"	80-88@1 <sup>3</sup> / <sub>16</sub> "	210-226@1 <sup>3</sup> / <sub>64</sub> "

### VALVE SPRINGS

**Remove** — Remove rocker arm cover, rocker arm assemblies and push rods. **NOTE** — Retain rocker arm assemblies and push rods in order, for reinstallation in original location. Remove spark plug on cylinder to be serviced and install suitable air line adaptor to spark plug port. Apply air pressure to hold valves in place. Using suitable tools (J-21934 and J-22534), compress valve spring and remove valve locks. Remove valve spring and retainer or rotator. Remove oil seal.

**Installation** — Use suitable valve spring tester (J-8056) to test valve springs. Replace those that are not within specifications. Reverse removal procedures while noting following: Valve springs must be installed with closed coil end facing cylinder head. Do not overcompress spring upon installation as damage may result to oil deflector. Push rods and rocker arm assemblies must be reinstalled in original locations.

### ROCKER ARM ASSEMBLY

Intake and exhaust rocker arms of each cylinder, pivot on a bridged pivot assembly which is secured to cylinder head by two capscrews.

### HYDRAULIC VALVE LIFTER ASSEMBLY

Lifters are serviced as complete assemblies only and parts are not interchangeable between lifters. Inspect for signs of scuffing on barrel and face of tappet body. Inspect tappet face for concave wear and if present, replacement of camshaft and tappets is necessary. If lifters are disassembled for cleaning and inspection, after reassembly (see illustration for arrangement of parts), they should be tested using suitable leak-down tester according to manufacturers instructions, Leak-down should take 20-110 seconds with a load travel of .125". Discard tappets not within specifications. **NOTE** — Do not fill tappet assemblies with engine oil prior to installation as they will charge themselves with 3-8 minutes of engine operation.

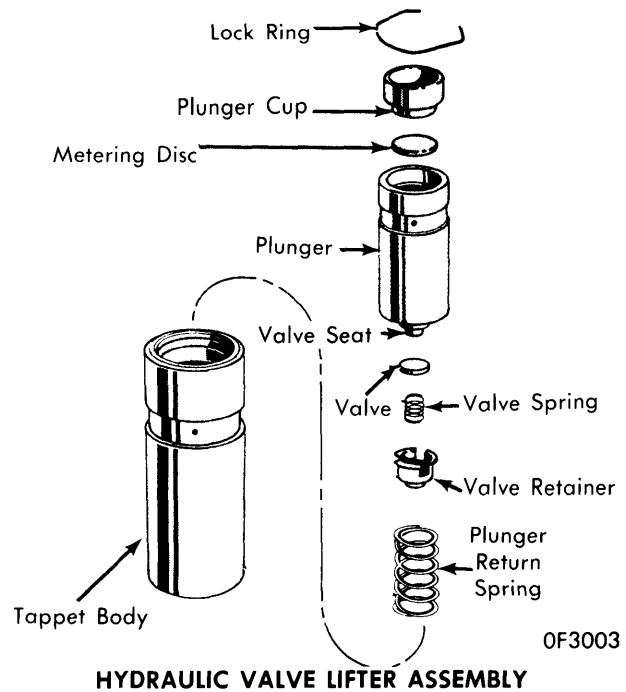

PISTONS, PINS, RINGS						
Engine	PISTONS	PINS		RINGS		
	Clearance	Piston Fit	Rod Fit	Rings	End Gap	Side Clearance
304"	.001-.0018"	.0003-.0005"	Press Fit	1	.010-.020"	.0015-.0035"
				2	.010-.020"	.0015-.0030"
				3	.010-.025"	.0011-.0080"
360"	.0012-.002"	.0003-.0005"	Press Fit	1	.010-.020"	.0015-.0030"
				2	.010-.020"	.0015-.0035"
				3	.015-.045"	.000-.007"
401"	.001-.0018"	.0003-.0005"	Press Fit	1	.010-.020"	.0015-.0030"
				2	.010-.020"	.0015-.0035"
				3	.015-.055"	.000-.007"

## 304", 360" &amp; 401" (Cont.)

## OIL PAN

See *Oil Pan Removal at end of ENGINE Section.*

## PISTON &amp; ROD ASSEMBLY

**Removal** — With cylinder head and oil pan removed, use a suitable ridge reamer to remove any ridge or deposits on upper end of cylinder bore. *NOTE* — *Piston must be at bottom of stroke and covered with cloth to collect cuttings.* Remove connecting rod bearing caps and retain in same order as removed. *NOTE* — *Caps and rods are stamped with corresponding cylinder number.* Cover connecting rod studs to protect cylinder walls and push piston and rod assembly out top of cylinder block.

**Installation** — 1) Piston rings must be positioned as follows: No. 1 compression ring gap must be 180° from No. 2 compression ring gap. Oil control ring spacer expander gap must be at least 90° from No. 2 compression ring gap. Oil control ring gaps must be 90° from expander gap with at least 30° between each ring gap. Upper and lower compression ring markings indicate top side of ring.

2) Lightly coat pistons, rings and cylinder walls with engine oil. Install suitable ring compressor on pistons making certain ring gap positions do not change. With connecting rod studs covered for cylinder wall protection, install each piston and rod assembly (with notch on piston head towards front of engine) in its respective bore. Guide connecting rod onto crankshaft journal while tapping piston head with hammer handle to seat connecting rod against crankshaft. Install mating rod cap and tighten rod cap nuts. *NOTE* — *With pistons installed, cylinder number should be outboard and squirt hole inboard.*

## FITTING PISTONS

Measure cylinder bore diameter  $2\frac{5}{16}$ " below top of cylinder bore. Measure piston at right angles to piston pin at centerline of pin. If clearance is not within specifications, replace piston.

## PISTON PINS

**Removal** — Place piston on suitable support and using suitable tool (J-21872) press pin from piston and rod with arbor press. Note position of pin through gauge window of remover support.

**Installation** — Using suitable pilot, driver and support (J-21872), press piston pin through connecting rod and piston until pin pilot indexes with mark on support. Pin should be centered in rod  $\pm\frac{1}{32}$ ". *NOTE* — *If little effort is required to install piston pin in connecting rod, or if rod moves along pin, a new connecting rod is required.* Check piston for freedom of movement on pin.

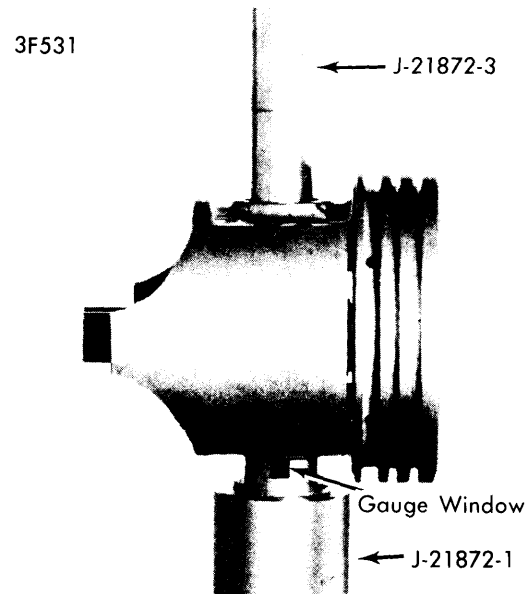

PISTON PIN REMOVAL &amp; INSTALLATION

## CRANKSHAFT MAIN &amp; CONNECTING ROD BEARINGS

Engine	MAIN BEARINGS				CONNECTING ROD BEARINGS		
	Journal Diam.	Clearance	Thrust Bearing	Crankshaft Endplay	Journal Diam.	Clearance	① Sideplay
304" & 360"	2.7482" ②	.001-.003"	No. 3	.003-.008"	2.0945"	.001-.003"	.006-.018"
401"	2.7482" ②	.001-.003"	No. 3	.003-.008"	2.2475"	.001-.003"	.006-.018"

① — Total two rods

② — Rear main is 2.7472"

## MAIN &amp; CONNECTING ROD BEARINGS

*NOTE* — *Following procedure is with oil pan removed.*

**Connecting Rod Bearings** — After ensuring rod caps are marked for cylinder identification, remove rod caps. Use Plastigage method to check for proper bearing clearances. If not within specifications, new bearings must be installed. New bearings are available in .001", .002", .010" and .012" undersize. Selective fitting is required on each connecting rod. A standard bearing may be used in combination with a .001" undersize or a .002" undersize in combination with a .001" undersize. *NOTE* — *Never use a new bearing with a used bearing. Never use a pair of bearings with more than .001"*

*difference in size on same journal.* Coat bearing surfaces with oil, install rod cap and tighten nuts.

**Main Bearings** — 1) Support crankshaft at counterweight adjacent to main bearing being checked and ensure that all bearing caps other than one being checked are tight. Starting with rear main bearing cap and working forward, remove one cap at a time and check bearing clearances using Plastigage method.

2) If clearances are not within specifications, bearings are available in .001", .002", .010" and .012" undersize. A standard bearing may be used in combination with a .001" undersize or a .002" undersize in combination with a .001" under-

## 304", 360" & 401" (Cont.)

size. **NOTE** — Never use a new bearing with a used bearing. Never use a pair of bearings with more than .001" difference in size on same journal.

3) Remove all upper bearings by inserting suitable tool in oil hole of crankshaft journal and rotating crankshaft clockwise to roll bearing from engine. Oil new bearing and rotate crankshaft so bearing will rotate in direction of its locating tang. Install bearing cap with lower bearing and tighten bolts.

### THRUST BEARING ALIGNMENT

When replacing thrust bearings (located at No. 3 main bearing journal), crankshaft should be moved fore and aft to align thrust faces of bearings.

### REAR MAIN BEARING OIL SEAL

**Removal** — Remove oil pan and rear main bearing cap. Loosen all remaining main bearing bolts. Using a brass drift, tap upper seal until it is protruding enough to permit pulling it out completely. Remove lower seal from bearing cap.

**Installation** — Reverse removal procedure while noting following: Lips of seal must face toward front of engine. Ensure seal is firmly seated in bearing cap recess. Use suitable sealer.

### ENGINE FRONT COVER

**Removal** — Drain cooling system and disconnect radiator hoses and bypass hose. Remove drive belts, fan and hub assembly, distributor, fuel pump, drive pulley and vibration damper. Remove A/C compressor and power steering pump without disconnecting hoses and position to one side. Remove alternator and mounting bracket from engine. Remove two front oil pan bolts. Remove bolts securing timing chain cover to block. **NOTE** — Bolts vary in length and must be installed in same location as removed. Pull cover forward until free of locating dowel pins.

**Installation** — Remove lower locating dowel pin from engine block and clean all gasket surfaces. Cut both sides of oil pan gasket flush with engine block. Using old gasket as a guide, trim new gasket to correspond to amount cut off at oil pan. Apply suitable sealer to both sides of gasket and install on engine front cover. Install front oil pan seal and align tongues of new oil pan gasket pieces with seal and cement into place on cover. Apply suitable sealer to cut-off edges of original oil pan gaskets and place cover into position, then install two front oil pan bolts. Tighten bolts slowly and evenly until cover aligns with upper locating dowel. Install lower dowel through cover and drive into corresponding hole in engine block. Install cover retaining bolts in same location as they were removed from and tighten.

### FRONT COVER OIL SEAL

**Removal & Installation** — Remove engine front cover and pry out seal from inside of cover. Clean seal bore and apply light coat of suitable sealer to outer surface of new seal. Drive seal into place from inside cover using suitable tool (J-22533). When seal contacts outer flange of cover it is installed correctly. Apply a light film of engine oil to lips of neoprene seal.

CAMSHAFT			
Engine	Journal Diam.	Clearance ①	Lobe Lift
304" & 360"	No. 1 2.120" ②	.001-.003"	.266"
401"	No. 1 2.120" ②	.001-.003"	.286"

① — Endplay is .000" with engine running.

② — Each succeeding journal .030" smaller than preceding journal.

### TIMING CHAIN

**Removal** — Remove engine front cover and crankshaft oil slinger. Remove camshaft sprocket retaining bolt and washer, distributor drive gear and fuel pump eccentric. Rotate crankshaft until timing mark on sprocket is aligned with camshaft sprocket timing mark (see illustration). Remove crankshaft sprocket, camshaft sprocket and timing chain as an assembly.

**Installation** — Assemble timing chain, crankshaft sprocket and camshaft sprocket with timing marks aligned (see illustration). Install assembly to crankshaft and camshaft. Install fuel pump eccentric and distributor drive gear. Install camshaft sprocket washer and retaining bolt, then tighten bolt. **NOTE** — Fuel pump eccentric must be installed with stamped word "REAR" facing camshaft sprocket. Install oil slinger, new cover gasket and front cover.

### CAMSHAFT

**Removal** — Drain cooling system and remove radiator assembly. Remove A/C condenser and receiver assembly (without disconnecting hoses) and position to one side. Remove rocker arm cover, rocker arm assemblies, push rods and hydraulic lifters. **NOTE** — Retain rocker arm assemblies, push rods and lifters in order, for reinstallation in original location. Remove engine front cover and timing chain. Remove hood latch support bracket upper retaining screws and move bracket (as required) for access to camshaft. Remove front bumper or grille (as required), and carefully remove camshaft.

**Installation** — Reverse removal procedure while noting following: Lubricate camshaft with suitable oil supplement and install camshaft carefully to avoid damage to camshaft lobes.

### CAMSHAFT BEARINGS

**Removal & Installation** — With camshaft removed, remove bearings using suitable bearing remover. Bearing bores are step-bored (largest at front, smallest at rear). Install bearings using suitable bearing installer and install camshaft.

### CAM LOBE LIFT

Remove rocker arm cover, rocker arm and bridged pivot assemblies, and spark plugs, then proceed as follows:

1) Use suitable clamping or mounting fixture, attach dial indicator to cylinder head so indicator probe rests on top of push rod with indicator and probe in a vertical position over push rod. Rotate crankshaft slowly until valve lifter is on heel of cam

## 304", 360" & 401" (Cont.)

lobe. At this point, push rod will be at its lowest point. **CAUTION** — If using an auxiliary starter switch, distributor primary lead must be disconnected from negative post of coil.

2) With push rod at lowest position, zero dial indicator and rotate engine until push rod is in fully raised position. Compare total lift recorded, with specifications.

2) Crank engine slowly in clockwise direction until dial indicator shows a lift of .020" (304" and 360" engines) or .025" (401" engines). Timing mark on vibration damper should be in line with TDC or zero marking on timing chain cover. If variation of more than 1/2" in either direction exists, remove timing chain cover and inspect timing chain installation.

VALVE TIMING				
Engine	INTAKE		EXHAUST	
	Open (BTDC)	Close (ALDC)	Open (BLDC)	Close (ATDC)
304" & 360"	15°	69°	57°	27°
401"	26°	91°	81°	43°

### VALVE TIMING

1) Remove spark plugs, rocker arm covers, and rocker arm assemblies from No. 1 cylinder. Rotate crankshaft until No. 6 piston is at TDC on compression stroke and rotate crankshaft counterclockwise 90° from this position. Install a dial indicator on No. 1 intake valve rocker arm push rod end. Set dial indicator to zero.

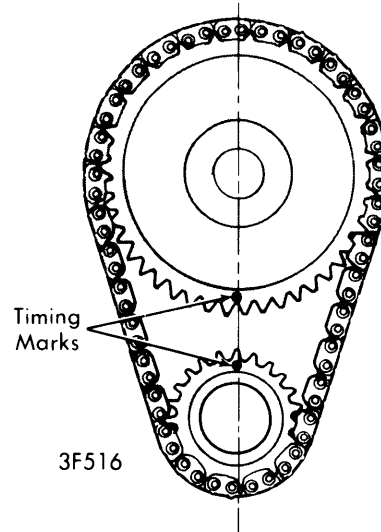

TIMING CHAIN SPROCKET ALIGNMENT

### ENGINE OILING

**Crankcase Capacity** — 4 quarts. Add 1 quart with filter change.

**Oil Filter** — Replace every 5000 miles or 5 months, whichever comes first.

**Normal Oil Pressure** — 13 psi minimum at 600 RPM and 37-75 psi maximum at 1600+ RPM.

**Pressure Regulator Valve** — Located in pump body. Not adjustable.

### ENGINE OILING SYSTEM

Oil is drawn from oil pan into gallery at lower right side of engine. A passage in timing chain cover channels oil into oil pump. Oil then flows through oil filter equipped with by-pass valve and to gallery extending to left front of engine. Oil passes directly to right main gallery and intersects with short passage leading to left main gallery. Engine components are then lubricated as follows:

**Crankshaft & Camshaft Bearings** — Passages extend down from right main oil gallery to each camshaft bearing and to each upper main bearing. Passages in crankshaft allow oil flow from main bearing journal to adjacent connecting rod journal. A squirt hole in connecting rod bearing cap distributes oil on cylinder walls, pistons and piston pins.

**Hydraulic Valve Lifters** — Lubricated directly from main oil galleries.

**Rocker Arms & Push Rods** — Oil is delivered from hydraulic lifters and passes through hollow push rods to rocker arms. Rocker arms direct oil onto valve train and oil returns to pan through channels in cylinder head.

**Timing Chain & Sprockets** — Oil is received from front camshaft bearing. Oil is thrown off sprockets to lubricate distributor gear and fuel pump eccentric. Oil returns to pan through cavity under front main bearing.

### OIL PUMP

Oil pump is driven by distributor drive shaft. Removal of pump will not affect ignition timing, as distributor gear remains meshed with camshaft gear. With pump cover and gasket removed, gears should project .002-.006" above pump body for proper clearance. **NOTE** — Gears must be up as far as

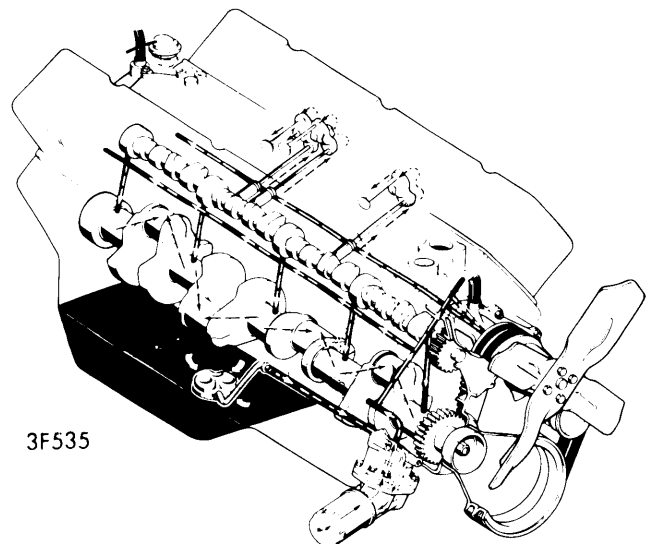

ENGINE OILING SYSTEM

## 304", 360" & 401" (Cont.)

### ENGINE OILING (Cont.)

possible into body. A clearance of .0005-.0025" should exist between gears and wall of gear cavity opposite point of gear mesh. Pump must be filled with petroleum jelly prior to installation of oil pump cover.

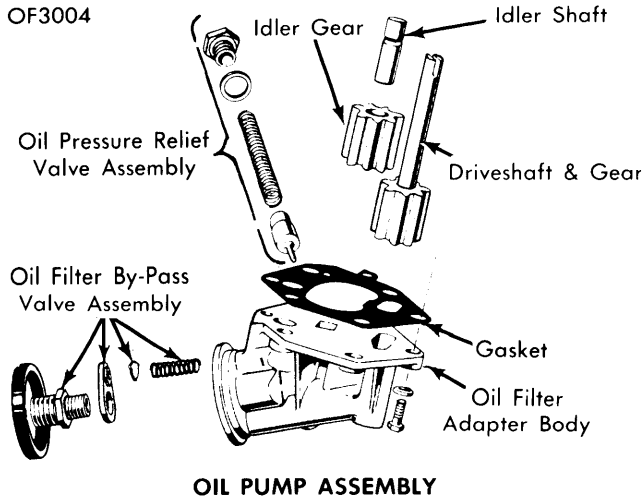

### TIGHTENING SPECIFICATIONS

Application	Ft. Lbs.
Cylinder Head .....	110
Intake Manifold .....	43
Exhaust Manifold .....	25
Oil Pan 1/4" .....	7
5/16" .....	11
Main Bearing Caps .....	100
Connecting Rod (304" & 360") .....	28
(401") .....	38
Flywheel to Crankshaft .....	105
Vibration Damper .....	55
Camshaft Sprocket .....	30
Rocker Arm Cap Screws .....	19
Engine Front Cover .....	25
Thermostat Housing .....	13
Water Pump .....	4
Oil Pump Cover .....	4.5
Air Injection Tube to Manifold .....	38