

GENERAL COOLING SYSTEM SERVICING (Cont.)

CAUTION – Pressure may build up fast. Release any excess pressure above the upper limit of pressure cap specifications or cooling system damage may result.

If needle does not fluctuate, race engine a few more times and check for water at tailpipe. Excessive water would indicate a faulty head gasket, cracked block or cylinder head near exhaust ports. Next, remove oil dipstick and if water globules appear in the oil, a serious internal leak is indicated.

ANTI-FREEZE CONCENTRATION

Test anti-freeze concentration using a suitable anti-freeze tester. The tester should have a temperature compensating feature, as failing to take temperature into consideration could cause an error as large as 30°F. Follow tester manufacturer's instructions for correct use of tester.

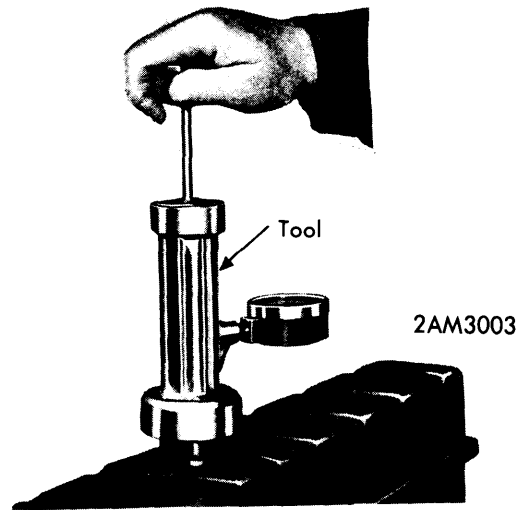

PRESSURE TESTING COOLING SYSTEM

COOLANT RECOVERY SYSTEMS

**American Motors
Chrysler Corp.
Ford Motor Co.
General Motors**

back into radiator. As a result, in a properly maintained cooling system, the only coolant losses will be through evaporation.

DESCRIPTION

A coolant recovery system differs from a normal cooling system in that a overflow bottle is connected to the radiator overflow hose. The overflow bottle is transparent or translucent to permit checking of coolant level without removing radiator cap. No adjustment or test is required beyond keeping vent hole or hose clean and checking pressure relief of radiator cap.

OPERATION

As coolant temperature rises and pressure in system exceeds pressure relief valve of radiator cap, due to expansion of coolant, excess coolant flows into overflow bottle. As engine cools and coolant contracts, vacuum is formed in system, drawing coolant, stored in overflow bottle,

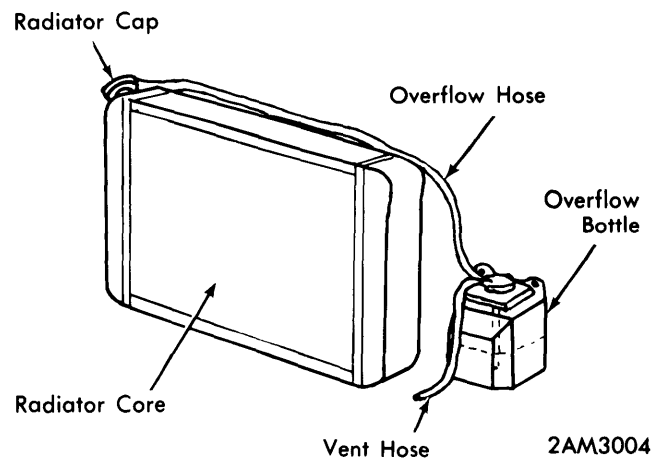

COOLANT RECOVERY SYSTEM (TYPICAL)