

GENERAL SPECIFICATIONS						
Engine	Net HP at RPM	Torque (Ft. Lbs. at RPM)	Compr. Ratio	Bore	Stroke	Displ. Cu. Ins.
232" 1-Bbl.	100 @ 3600	185 @ 1800	8.0-1	3.75"	3.50"	232
258" 1-Bbl.	110 @ 3500	195 @ 2000	8.0-1	3.75"	3.895"	258

► **NET HORSEPOWER & TORQUE NOTE** — Horsepower and Torque figures given above are NET. Net Horsepower and Torque represents power at the flywheel when the engine is installed in a vehicle, with wide open throttle and all systems operating such as; air cleaner, exhaust system, water pump, generator, oil pump and air conditioning.

## ENGINE IDENTIFICATION

Engine number is located on machined pad on cylinder block between number two and three cylinders. Letter contained in code number identifies engine by CID, carburetor type and compression ratio.

Code	CID	Carb.	Comp. Ratio
A.....	258.....	1-Bbl.....	8.0-1
E.....	232.....	1-Bbl.....	8.0-1

## SPECIAL ENGINE MARKS

Some engines are produced at factory with oversize or undersize components. These engines are identified by a letter code stamped on boss between ignition coil and distributor. Letters are decoded as follows:

- B** — All cylinder bores .010" oversize.
- C** — All camshaft bearing bores .010" oversize.
- M** — All main bearing journals .010" undersize.
- P** — All connecting rod journals .010" undersize.

## ENGINE REMOVAL

- 1) Remove hood (mark hinge positions), air cleaner and disconnect battery cables. Drain cooling system and crankcase. Remove radiator shroud and radiator. Remove fan, disconnect power steering pump bracket and position to one side without disconnecting hoses. Discharge refrigerant from A/C compressor and remove condenser and receiver assembly.
- 2) Disconnect all wires, hoses, lines and linkage from engine and transmission. Disconnect exhaust pipe at support bracket and exhaust manifold. Remove oil filter. Remove front support mount-to-frame retaining nuts, support engine and remove mount and bracket assemblies from engine.
- 3) Remove transfer case shift lever boot, floor mat, transmission access cover and starter motor. If equipped with automatic transmission, remove upper bolts securing transmission bell housing to engine, engine adapter plate inspection covers, then mark assembled position of converter and flex plate and remove converter-to-flex plate bolts. Remove remaining bolts securing bell housing to engine.
- 4) If equipped with manual transmission, remove upper bolts securing clutch housing to engine, lower cover and then remove remaining bolts securing clutch housing to engine. On all vehicles, support transmission with suitable jack and remove engine by pulling forward and upward.

## INTAKE & EXHAUST MANIFOLDS

**Removal** — Remove air cleaner and carburetor. Disconnect accelerator cable at bellcrank, PCV vacuum hose from manifold and TCS solenoid vacuum valve and bracket from

manifold. Disconnect vacuum hoses from EGR valve, exhaust pipe from manifold flange. Disconnect A/C compressor and bracket assembly and position to one side. Remove manifold attaching bolts, nuts and clamps. Remove intake and exhaust manifold as an assembly. Separate manifolds at heat riser area.

**Installation** — Clean all mating surfaces of manifolds and cylinder head. Assemble manifolds and finger tighten heat riser retaining nuts. Position new intake manifold gasket on cylinder head and install manifold assembly. Tighten manifold attaching bolts and nuts in sequence (see illustration).

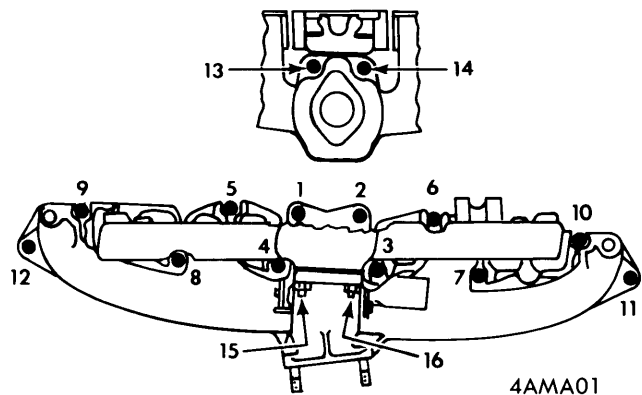

## INTAKE MANIFOLD TIGHTENING SEQUENCE CYLINDER HEAD

**Removal** — Drain cooling system and disconnect radiator hose at thermostat housing. Remove rocker arm cover, rocker arm and shaft assembly and push rods. *NOTE* — Retain push rods in order, for reinstallation in original location. Remove intake and exhaust manifold assembly from cylinder head. Remove spark plugs and disconnect temperature sending unit wire, battery ground cable and ignition coil and bracket assembly. Remove cylinder head bolts, cylinder head and gasket.

**Installation** — Clean gasket mounting surfaces. Coat head gasket with suitable sealer and position on block with word "TOP" facing upward. Install cylinder head and bolts. Tighten bolts in sequence (see illustration).

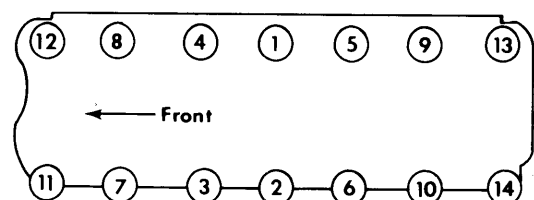

## CYLINDER HEAD TIGHTENING SEQUENCE

# Jeep 6 Engines

VALVES								
Engine & Valve	Head Diam.	Face Angle	Seat Angle	Seat Width	Stem Diameter	Stem Clearance	Valve Lift	
All Engines	Int.	1.787"	29°	30°	.040-.060"	.3715-.3725"	.001-.003"	.....
	Exh.	1.406"	44°	44.5°	.040-.060"	.3715-.3725"	.001-.003"	.....

## VALVE ARRANGEMENT

E-I-I-E-I-E-E-I-E-I-E-I-E (front to rear).

## VALVE GUIDE SERVICING

Valve guides are integral with cylinder head. If valve stem-to-guide clearance is not within specifications, ream guide to install valve with oversize stem. Valves are available in .003", .015" and .030" oversize. **CAUTION** — Ream valve guides in steps, starting with .003" reamer and progressing to size required. Reface valve seat and use suitable tool to break sharp corner (ID) of guide after reaming for oversize valve stem.

## VALVE STEM OIL SEALS

Rubber (black color) or nylon (white color) oil deflector used on all valves. During repairs which require gasket sets, insure that deflectors used are nylon type to provide better oil control at valve stems.

VALVE SPRINGS			
Engine	Free Length	PRESSURE (LBS.)	
		Valve Closed	Valve Open
All Engines	①	95-105 @ 1 13/16"	188-202 @ 1 1/16"
	②	80-88 @ 1 5/8"	210-226 @ 1 3/16"

- ① — W/O Rotators.
- ② — W/Rotators.

## VALVE SPRINGS

**Removal** — Remove rocker arm cover, rocker arm and shaft assembly and push rods. Remove spark plug on cylinder to be serviced and install suitable air line adaptor to spark plug port. Apply air pressure to hold valves in place. Using suitable tool (J-21931), compress valve spring and remove valve locks. Remove valve spring and retainer or rotator. Remove oil deflector if necessary. Remove exhaust valve spring seat (if equipped).

**Installation** — Use suitable valve spring tester (J-8056) to test valve springs and replace those that are not within specifications. Reverse removal procedures while noting following: Valve springs must be installed with closed coil end facing cylinder head. Tap spring from side-to-side to be certain spring is seated properly at cylinder head after valve locks are installed. Do not overcompress spring as damage may result to oil deflector. Push rods must be reinstalled in original position.

## ROCKER ARM ASSEMBLY

Assemble rocker arm components in same order as removed. Rocker arm shaft oil holes must face toward cylinder head.

Push rods and rocker arms must be aligned properly. Tighten retaining bolts evenly from center of shaft outward. Deflector must face push rod side of engine. See illustration for arrangement of parts.

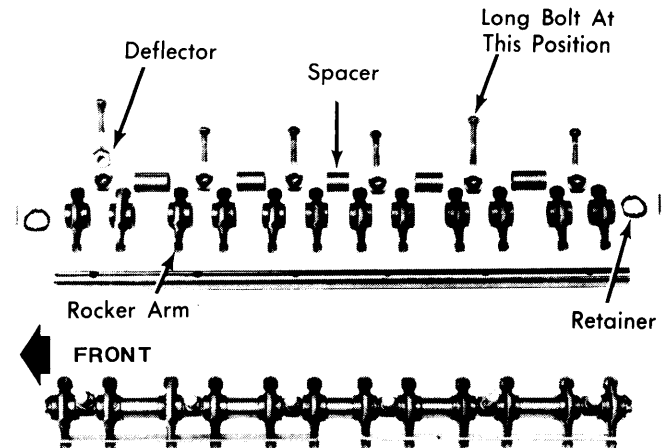

4AM03

## ROCKER ARMS AND SHAFT ASSEMBLY

## HYDRAULIC VALVE LIFTER ASSEMBLY

Lifters are serviced as complete assemblies only and parts are not interchangeable between lifters. Inspect for signs of scuffing on barrel and face of tappet body. Inspect tappet face for concave wear and if present, replacement of camshaft and tappets is necessary. If lifters are disassembled for cleaning and inspection, after reassembly (see illustration for arrangement of parts), they should be tested using suitable leak-down tester according to manufacturer's instructions. Leak-down should take 20-110 seconds with a load travel of .125". Discard tappets not within specifications. **NOTE** — Do not fill tappet assemblies with engine oil prior to installation as they will charge themselves with 3-8 minutes of engine operation.

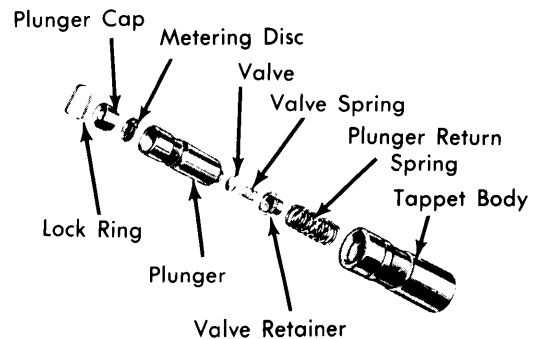

4AMA04

## HYDRAULIC VALVE LIFTER ASSEMBLY

PISTONS, PINS, RINGS						
Engine	PISTONS	PINS		RINGS		
	① Clearance	Piston Fit	Rod Fit	Rings	End Gap	Side Clearance
All Engines	.0009-.0017"	.0003-.0005"	Press Fit	1	.010-.020"	.0015-.003"
				2	.010-.020"	.0015-.003"
				3	.010-.025"	.001-.008"

① — Right angle to center line of piston pin.

## OIL PAN

**Removal** — Raise vehicle and drain crankcase. Remove starter motor. On CJ models, position suitable jack under transmission bell housing, disconnect engine right mount and raise engine to allow clearance for oil pan removal. Remove oil pan, front and rear seals and side gaskets.

**Installation** — Clean all gasket surfaces. Install front seal to timing chain cover and use suitable sealer on end tabs. Use sealer to secure oil pan side gaskets to block. *NOTE — End tabs of side gaskets must have sealer.* Coat inside curved surface of rear seal with soap and use suitable sealer on gasket contacting surface of seal end tabs. Install seal in recess of rear bearing cap, making certain seal is fully seated. Apply engine oil to oil pan contacting surface of front and rear seals. Install oil pan and tighten bolts.

## PISTON & ROD ASSEMBLY

*NOTE — New pistons must be installed in same cylinders for which they were fitted, and used pistons in same cylinder from which they were removed.*

**Removal** — With cylinder head and oil pan removed, use a suitable ridge reamer to remove any ridge or deposits on upper end of cylinder bore. *NOTE — Piston must be at bottom of stroke and covered with cloth to collect cuttings.* Remove connecting rod bearing caps and retain in same order as removed. *NOTE — Caps and rods are stamped with corresponding cylinder number.* Install rubber hose over connecting rod studs to protect cylinder walls and push piston and rod assembly out top of cylinder block.

**Installation** — 1) Piston rings must be positioned as follows: No. 1 compression ring gap must be 180° from No. 2 compression ring gap. Oil control ring spacer expander gap must be at least 90° from No. 2 compression ring gap. Oil control ring gaps must be 90° from expander gap with at least 30° between each ring gap. Upper and lower compression ring markings indicate top side of ring .

2) Lightly coat pistons, rings and cylinder walls with engine oil. Install suitable ring compressor on pistons making certain ring gap positions do not change. With connecting rod studs covered for cylinder wall protection, install each piston and rod assembly (with notch on piston head towards front of engine) in its respective bore. Guide connecting rod onto crankshaft journal while tapping piston head with hammer

handle to seat connecting rod against crankshaft. Install mating rod cap and tighten rod cap nuts.

## FITTING PISTONS

Measure cylinder bore diameter 2 5/16" below top of cylinder bore. Measure piston at right angles to piston pin at centerline of pin. Pistons are available in .010" oversize.

## PISTON PINS

**Removal** — Place piston on suitable support and using suitable tool (J-21872) press pin from piston and rod with arbor press. Note position of pin through gauge window of remover support.

**Installation** — Using suitable pilot, driver and support (J-21872) press piston pin through connecting rod and piston until pin pilot indexes with mark on support. Pin should be centered in rod plus or minus 1/32". *NOTE — If little effort is required to install piston pin in connecting rod, or if rod moves along pin, a new connecting rod is required.* Check piston for freedom of movement on pin.

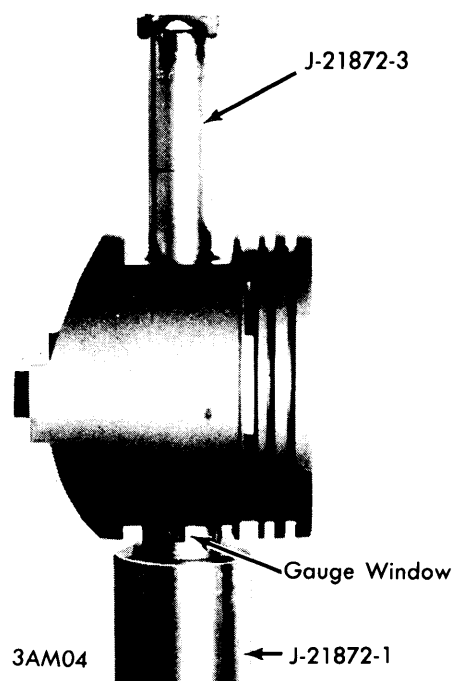

PISTON PIN REMOVAL & INSTALLATION

# Jeep 6 Engines

CRANKSHAFT MAIN & CONNECTING ROD BEARINGS							
Engine	MAIN BEARINGS				CONNECTING ROD BEARINGS		
	Journal Diam.	Clearance	Thrust Bearing	Crankshaft Endplay	Journal Diam.	Clearance	Sideplay
All Engines	2.4994"	.001-.003"	3	.0015-.0065"	2.0944"	.001-.003"	.005-.014"

## MAIN & CONNECTING ROD BEARINGS

*NOTE — Following procedure is with oil pan removed.*

**Connecting Rod Bearings** — After ensuring rod caps are marked for cylinder identification, remove rod caps. Use Plastigage method to check for proper bearing clearances. If not within specifications, new bearings must be installed. New bearings are available in .001", .002", .010" and .012" undersize. Selective fitting is required on each connecting rod. A standard bearing may be used in combination with a .001" undersize or a .002" undersize in combination with a .001" undersize. *NOTE — Never use a new bearing with a used bearing. Never use a pair of bearings with more than .001" difference in size on same journal.* Coat bearing surfaces with oil, install rod cap and tighten nuts.

**Main Bearings** — 1) Support crankshaft at counterweight adjacent to main bearing being checked and ensure that all bearing caps other than one being checked are tight. Starting with rear main bearing cap and working forward, remove one cap at a time and check bearing clearances using Plastigage method.

2) If clearances are not within specifications, bearings are available in .001", .002", .010" and .012" undersize. A standard bearing may be used in combination with a .001" undersize or a .002" undersize in combination with a .001" undersize. *NOTE — Never use a new bearing with a used bearing. Never use a pair of bearings with more than .001" difference in size on same journal.*

3) Remove all upper bearings by inserting suitable tool in oil hole of crankshaft journal and rotating crankshaft clockwise to roll bearing from engine. Oil new bearing and rotate crankshaft so bearing will rotate in direction of its locating tang. Install bearing cap with lower bearing and tighten bolts.

## THRUST BEARING ALIGNMENT

When replacing thrust bearings (located at No. 3 main bearing journal), crankshaft should be moved fore and aft to align thrust faces of bearings.

## REAR MAIN BEARING OIL SEAL

**Removal** — Remove oil pan and rear main bearing cap. Loosen all remaining main bearing bolts. Using a brass drift, tap upper seal until seal is protruding enough to permit pulling it out completely. Remove lower seal from bearing cap.

**Installation** — Reverse removal procedure while noting following: Lip of seal must face toward front of engine. Ensure seal is firmly seated in bearing cap recess. Use suitable sealer and apply as indicated in illustration.

## ENGINE FRONT COVER

**Removal** — Remove drive belt(s), fan and hub assembly, accessory pulley (if equipped) and vibration damper. Remove oil pan-to-timing chain cover screws and cover-to-block screws. Raise cover enough to detach retaining tips of oil pan seal from bottom side of cover. Remove cover and gasket from engine. Cut off oil pan seal end tabs flush with front face of cylinder block and remove seal.

**Installation** — Clean all gasket mounting surfaces. Apply suitable sealing compound to both sides of cover gasket and position on cylinder block. Cut end tabs of a new oil pan seal as described under removal and position seal on cover after using suitable sealer on seal end tabs. Position engine front cover on cylinder block. Use suitable tool to align front cover and install cover-to-block screws and oil pan-to-cover screws. Tighten all screws. Remove alignment tool and install vibration damper, pulley, fan and hub assembly and drive belt(s).

## FRONT COVER OIL SEAL

**Removal & Installation** — Remove drive belt(s), accessory drive pulley and vibration damper. Remove oil seal using suitable tool (J-9256). To install new seal, apply light film of suitable sealer on outside diameter of seal and position on cover with seal lip facing outward. Use suitable tool (J-9163) to press seal into cover until it bottoms. Apply light film of engine oil on seal lip and install vibration damper, accessory drive and drive belt(s).

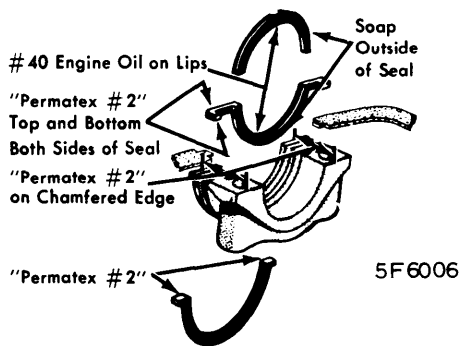

REAR MAIN BEARING OIL SEAL

CAMSHAFT			
Engine	Journal Diam.	Clearance	Lobe Lift
All Engines			
No. 1	2.0295"	.001-.003"	2.54"
No. 2	2.0195"		
No. 3	2.0095"		
No. 4	1.9995"		

## TIMING CHAIN

**Removal** — Remove engine front cover. Remove camshaft sprocket retaining bolt and washer. Rotate crankshaft until

timing mark on sprocket is aligned with camshaft sprocket timing mark (see illustration). Remove sprockets and timing chain as an assembly.

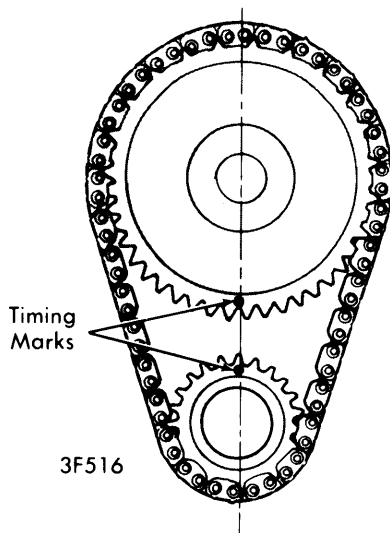

## TIMING CHAIN SPROCKET ALIGNMENT

**Installation** — Assemble timing chain, crankshaft sprocket and camshaft sprocket with timing marks aligned (see illustration). Install assembly to crankshaft and camshaft. Install camshaft sprocket retaining bolt and washer, then tighten.

## CAMSHAFT

**Removal** — Remove radiator, cylinder head, hydraulic lifters, engine front cover and timing chain. Remove fuel pump, distributor and ignition wires. Remove front bumper or grille as required and carefully remove camshaft.

**Installation** — Reverse removal procedure while noting following: Lubricate camshaft with suitable oil supplement and install camshaft carefully to avoid damage to camshaft lobes.

## CAMSHAFT BEARINGS

**Removal & Installation** — With camshaft removed, remove bearings using suitable bearing remover. Bearing bores are step-bored (largest at front, smallest at rear). Install bearings using suitable bearing installer and install camshaft.

**Crankcase Capacity** — 5 quarts. Add 1 quart with filter change.

**Oil Filter** — Replace every 5000 miles or 5 months, whichever comes first.

**Normal Oil Pressure** — 13 psi minimum at 600 RPM and 37-75 psi at 1600+ RPM.

**Pressure Regulator Valve** — Located in pump body. Not adjustable.

## ENGINE OILING SYSTEM

Oil under pressure is directed from oil pump to a full-flow oil filter. In case filter becomes clogged and restricts full flow of

## CAM LOBE LIFT

Remove rocker arm cover, rocker arm and shaft assembly and spark plugs, then proceed as follows:

1) Using suitable clamping or mounting fixture, attach dial indicator to cylinder head so indicator probe rests on top of push rod with indicator and probe in a vertical position over push rod.

2) Rotate crankshaft slowly until valve lifter is on heel of cam lobe. At this point, push rod will be at its lowest point. **CAUTION** — If using an auxiliary starter switch, distributor primary lead must be disconnected from negative post of coil.

3) With push rod at lowest position, zero dial indicator and rotate engine until push rod is in fully raised position. Compare total lift recorded with specifications. If less than specifications, camshaft is defective. Check all remaining lobes of camshaft in same manner.

## VALVE TIMING

Engine	INTAKE		EXHAUST	
	Open (BTDC)	Close (ALDC)	Open (BLDC)	Close (ATDC)
All Engines	12°30'	66°30'	53°30'	25°30'⓪

⓪ — With EGR 55° 30'.

## VALVE TIMING

Remove spark plugs and rocker arm cover. Rotate crankshaft until No. 6 piston is at TDC on compression stroke. Rotate crankshaft counterclockwise 90°. Install dial indicator with indicator point touching No. 1 cylinder intake rocker arm at push rod end and set dial indicator to zero. Rotate crankshaft clockwise until dial indicator shows .016" lift. Timing mark on vibration damper should index with TDC mark on engine front cover. If timing mark is more than ½" off TDC in either direction, valve timing is incorrect.

## ENGINE OILING

oil, a by-pass valve is located in filter mounting base. From oil filter, oil flow is directed as follows:

**Crankshaft & Camshaft Bearings** — Main and camshaft bearings receive oil from main oil gallery. From main bearings oil passes through passage in crankshaft to connecting rod bearings. Oil throw-off from each connecting rod bearing lubricates cylinder walls, piston pins, camshaft lobes and distributor drive gear.

**Hydraulic Valve Tappets** — Lubricated directly from main oil gallery.

**Timing Chain & Sprockets** — Oil is received from front camshaft bearing and returns to crankcase through cavity under front main bearing cap.

# Jeep 6 Engines

## ENGINE OILING (Cont.)

**Rocker Arms & Push Rods** — Oil from main gallery metered through groove in No. 3 camshaft bearing surface to gallery extending to rocker arm shaft at No. 5 rocker arm support. Oil flows into shaft and supplies lubrication to rocker arms and push rods. Oil returns to crankcase through valve tappet area.

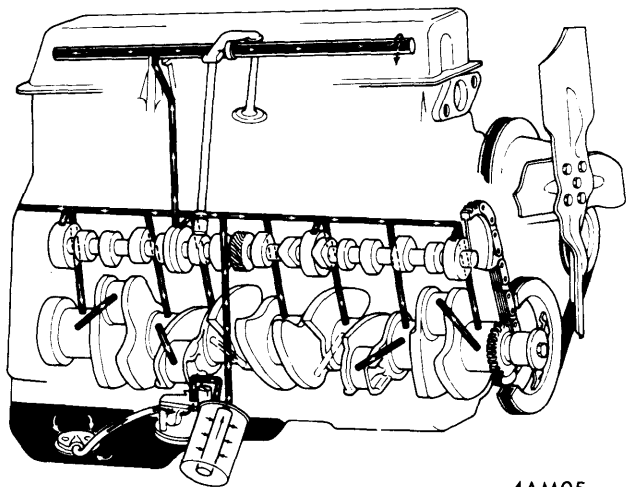

4AM05

**ENGINE OILING SYSTEM**

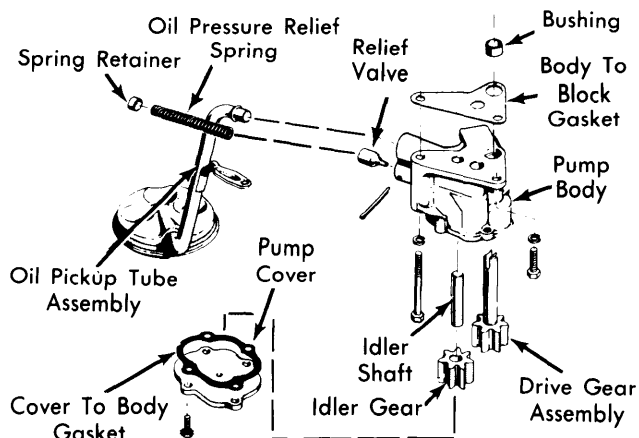

4AM06

**OIL PUMP ASSEMBLY**

### TIGHTENING SPECIFICATIONS

Application	Ft. Lbs.
Camshaft Sprocket .....	50
Connecting Rod Nuts.....	28
Cylinder Head .....	105
Drive Plate-to-Converter .....	22
Engine Front Cover.....	5
Exhaust Manifold.....	23
Flywheel-to-Crankshaft.....	105
Fuel Pump .....	16
Intake Manifold.....	23
Main Bearing Caps .....	80
Oil Pan	
(1/4").....	7
(5/16").....	11
Oil Pump Cover.....	6
Oil Pump Screw	
(Short).....	10
(Long).....	17
Thermostat Housing .....	13
Vibration Damper.....	55
Water Pump .....	13
Rocker Arm Assembly .....	21

### OIL PUMP

Oil pump is driven by distributor drive shaft. Removal of pump will not affect ignition timing, as distributor gear remains meshed with camshaft gear. With pump cover and gasket removed, gears should project .002-.006" above pump body for proper clearance. A clearance of .0005-.0025" should exist between gears and wall of gear cavity opposite point of gear mesh. Pump must be filled with petroleum jelly prior to installation of oil pump cover. **CAUTION** — Oil inlet tube position must be changed to allow removal of relief valve; therefore, pickup tube assembly must be replaced upon installation and suitable sealer used.