

2000 CC & 2300 CC

| GENERAL SPECIFICATIONS | | | | | | |
|------------------------|---------------|--------------------------|--------------|--------|--------|-----------------|
| Engine | Net HP At RPM | Torque (Ft. Lbs. at RPM) | Compr. Ratio | Bore | Stroke | Displ. Cu. Ins. |
| 2000 cc | | | ... | 3.575" | 3.029" | 122.0 |
| 2300 cc | | | | 3.78" | 3.126" | 140.0 |

ENGINE IDENTIFICATION

Engine may be identified from the official Vehicle Identification Number. Number is stamped on a metal tab fastened to instrument panel close to windshield on drivers side of car and visible from outside. The Identification number contains eleven digits. Example: 3S10X100001. The first digit establishes model year and fifth digit engine identification.

| Engine | Engine Code |
|--------------|-------------|
| 2000 cc..... | X |
| 2300 cc..... | Y |

ENGINE REMOVAL

- 1) Drain crankcase and cooling system. Disconnect all electrical wiring, vacuum and water hoses. Remove radiator and fan. Remove A/C compressor from mounting bracket and lay aside with refrigerant lines attached.
- 2) Disconnect flexible fuel line from fuel tank line and remove starter. Raise vehicle and remove flywheel or converter housing upper bolts. Disconnect exhaust pipe at manifold, then right and left engine mounts at underbody bracket. Remove flywheel or converter housing cover.
- 3) With manual transmission, remove flywheel housing lower bolts. With automatic transmission, disconnect converter from flywheel and remove converter housing lower bolts.
- 4) Lower vehicle and support transmission on a jack. Attach suitable lifting tackle to engine lifting brackets and lift engine from vehicle.

INTAKE MANIFOLD

Removal - Remove air cleaner and disconnect fuel line from carburetor. Disconnect vacuum lines and crankcase ventilation hose at intake manifold. Remove attaching nuts and lift manifold, carburetor and decel valve off as an assembly.

Installation - Clean gasket material from cylinder head and manifold. Install new gasket on cylinder head and install manifold. Tighten nuts to specification in sequence shown in illustration.

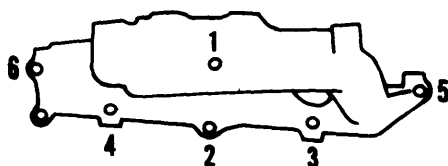

3AM3007

2000 cc INTAKE MANIFOLD TIGHTENING SEQUENCE

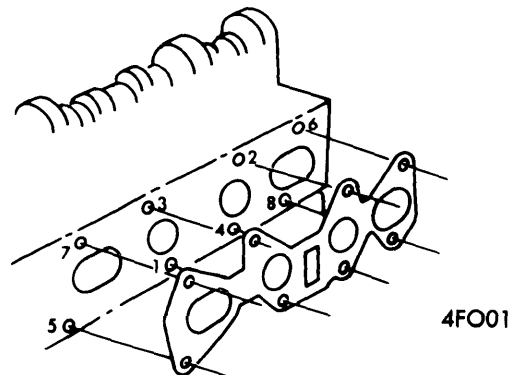

2300 cc INTAKE MANIFOLD TIGHTENING SEQUENCE

EXHAUST MANIFOLD

Removal - Remove air cleaner and two attaching nuts from top of exhaust manifold shroud. Remove attaching nuts from muffler inlet pipe and manifold and remove exhaust manifold.

Installation - Apply light film of graphite grease on exhaust manifold and install manifold. Tighten nuts to specification in sequence shown in illustration.

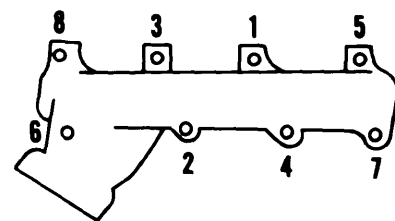

3AM3011

2000 cc EXHAUST MANIFOLD TIGHTENING SEQUENCE

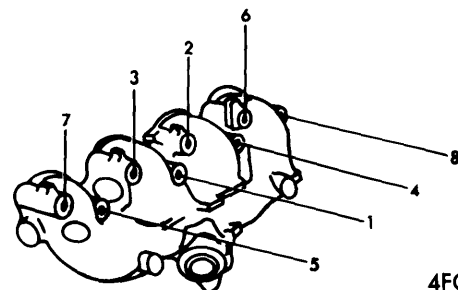

4FO02

2300 cc EXHAUST MANIFOLD TIGHTENING SEQUENCE

Ford 4 Engines

2000 CC & 2300 CC (Cont.)

CYLINDER HEAD

Removal — Drain cooling system, remove air cleaner and rocker arm cover. Remove exhaust manifold, intake manifold, carburetor and decel valve. Remove camshaft drive belt cover. Loosen drive belt tensioner and remove belt. Remove water outlet elbow from cylinder head. On 2300 cc engines, remove bolt from inner cover to cylinder head. Remove bolts and lift head and camshaft assembly from engine.

Installation — Clean gasket material from cylinder head and block. Install guide pins in cylinder block holes nine and seven (2000 cc only). Install new gasket on block and install cylinder head and camshaft assembly onto block. Install bolts and tighten in two steps in sequence (see illustration).

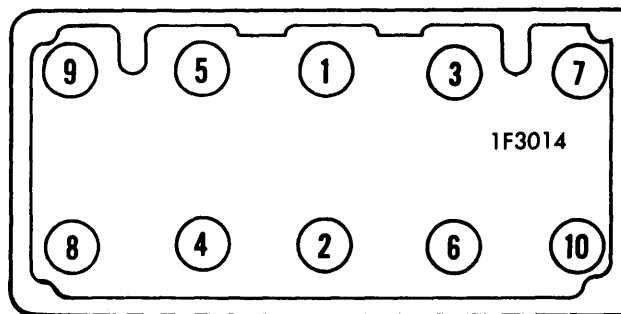

CYLINDER HEAD TIGHTENING SEQUENCE

| VALVES | | | | | | | |
|----------------|------------|------------|------------|------------|---------------|----------------|------------|
| Engine & Valve | Head Diam. | Face Angle | Seat Angle | Seat Width | Stem Diameter | Stem Clearance | Valve Lift |
| 2000 cc Int. | 1.653" | 44° | 45° | .060-.079" | .3159-.3167" | .0008-.0025" | .3993" |
| Exh. | 1.417" | 44° | 45° | .060-.079" | .3149-.3156" | .0018-.0035" | .3993" |
| 2300 cc Int. | 1.736" | 44° | 45° | .060-.090" | .3416-.3423" | .0010-.0027" | .4000" |
| Exh. | 1.500" | 44° | 45° | .070-.090" | .3411-.3418" | .0015-.0022" | .4000" |

VALVE ARRANGEMENT

E-I-E-I-E-I-E-I

VALVE GUIDES

If valve guides become worn they may be reamed to install a new valve with oversize stem. When going from a standard size stem to oversize, always use reamers in sequence to obtain final desired bore. Valve seat must be refaced after guide has been reamed, and a suitable tool used to break sharp corner (ID) of guide.

VALVE STEM OIL SEALS

With valve in head, place plastic installation cap over end of valve stem. Start stem seal carefully over cap and push seal down until jacket touches top of valve guide. Remove plastic cap and bottom seal on valve guide.

| VALVE SPRINGS | | | |
|---------------|-------------|-----------------|----------------|
| Engine | Free Length | PRESSURE (LBS.) | |
| | | Valve Closed | Valve Open |
| 2000 cc | 1.73" | 64-73 @ 1.418 | 170-183 @ 1.02 |
| 2300 cc | 1.816" | 78-86 @ 1.56 | 199-221 @ 1.16 |

VALVE SPRINGS

Removal — Remove exhaust manifold shroud and valve rocker arm cover. Remove both rocker arms (cam followers) from cylinder being serviced. Remove spark plug from cylinder and install air line and adapter to cylinder with a minimum of 140 psi line pressure. **NOTE** — If air pressure does not hold valve shut, remove cylinder head for inspection. Use suitable

tool to compress valve spring and remove retainer locks, spring retainer valve spring. Remove and discard valve stem seal. **CAUTION** — Do not remove air pressure.

Installation — Install new valve stem oil seal, valve spring and retainer. Compress spring and install valve spring retainer locks. **CAUTION** — Do not compress spring more than is necessary to install locks. Remove compressor tool, turn off air and remove adapter. Apply Lubriplate to all contact surfaces of rocker arms and install in position. **NOTE** — On 2300 cc engines, ensure that the affected lash adjuster has been collapsed and release before rotating camshaft.

VALVE SPRING INSTALLED HEIGHT

Measure assembled height of valve spring from surface of spring pad to underside of spring retainer. If height is not within specifications, install .030" spacer(s) between spring and pad to obtain recommended height. Do not install spacers unless necessary, as excess use of spacers will result in overstressing valve springs and overloading camshaft lobe.

Spring Height Specifications

| Engine | Installed Height |
|--------------|---|
| 2000 cc..... | 1 ²⁵ / ₆₄ "-1 ²⁷ / ₆₄ " |
| 2300 cc..... | 1 ³⁵ / ₆₄ "-1 ³⁷ / ₆₄ " |

VALVE CLEARANCE ADJUSTMENT (2000 CC)

- 1) Rocker arm retaining spring must be removed to accurately check valve clearance. Use a flat blade screwdriver to reach under spring at the rocker arm, then snap spring up and off.
- 2) Rotate crankshaft (clockwise only) until number one cam lobe is pointed down (valve spring depressed). Check clearance between cam lobe and rocker arm of valves indicated in specifications table. To adjust, loosen lock nut and turn adjustment screw in to increase clearance or out to decrease.

2000 CC & 2300 CC (Cont.)

3) Repeat procedure for valves two, three and six and check clearances indicated in specifications table. After completing adjustments, snap rocker arm retaining springs into place and check that lock nuts on adjustment screws are tight.

Valve Clearance Specifications

| Valves Open | Adjust To | Adjust To |
|-------------|------------|-----------|
| | .008" | .010" |
| No. 1..... | No. 6..... | No. 7 |
| No. 2..... | No. 8..... | No. 3 |
| No. 3..... | No. 2..... | No. 5 |
| No. 6..... | No. 4..... | No. 1 |

HYDRAULIC LASH ADJUSTER ASSEMBLY (2300 cc)

Two types of hydraulic lash adjusters are used in 2300 cc engines. Clean and inspect all parts of assembly. Replace the

entire assembly if plunger is not free in body. Assemble lifter assembly and check for freeness of operation by pressing down on the cap. Lifters may also be checked with a hydraulic tester to check leak down rate.

HYDRAULIC LASH ADJUSTER ADJUSTMENT (2300 cc)

Position camshaft so high point of cam lobe is facing away from valve (valve closed) to be checked. Remove coil spring holding cam follower arm to lash adjuster (if equipped). Use suitable tool (T74P-6565-B) to slowly apply pressure to cam follower until lash adjuster is completely collapsed. Hold in this position and check clearance between follower and cam. If not within specifications (Intake .008" and Exhaust .010" cold) inspect cam follower, valve spring installed height, and cam.

| PISTONS, PINS, RINGS | | | | | | |
|----------------------|--------------|--------------|-----------|------------|---------------------------|----------------------|
| Engine | PISTONS | PINS | | RINGS | | |
| | Clearance | Piston Fit | Rod Fit | Rings | End Gap | Side Clearance |
| 2000 cc | .001-.002" | .0002-.0004" | Press Fit | 1 & 2 3 | .015-.0229" .016-.055" | .0019-.0038" Snug |
| 2300 cc | .0013-.0021" | .0002-.0004" | Press Fit | 1 & 2 3 | .010-.020" .015-.055" | .002-.004" Snug |

OIL PAN

Removal - Drain crankcase, remove oil dipstick and flywheel housing inspection cover. Disconnect steering cable from rack and pinion, then disconnect rack and pinion from crossmember and move it forward. Remove oil pan bolts and remove oil pan.

Installation - Coat block and gasket with oil resistant sealer and position gaskets on cylinder block. Position end seals and install pan. Tighten bolts evenly in sequence shown in illustration.

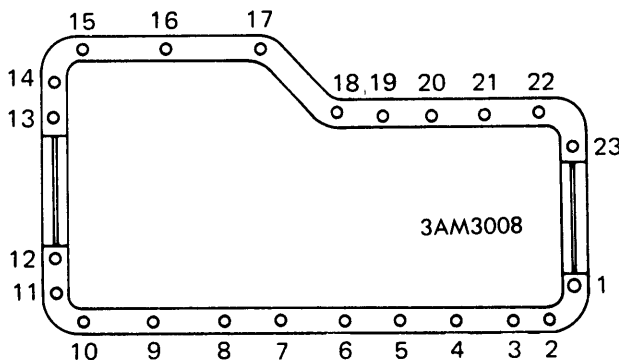

OIL PAN TIGHTENING SEQUENCE

PISTON & ROD ASSEMBLY

Removal - Remove ridge at top of cylinder bores using suitable ridge reamer before removing pistons from block. **NOTE** - Keep tops of pistons covered during this procedure. Rotate crankshaft and inspect connecting rods and rod caps for cylinder identification. Identify them if necessary. Remove

rod cap and push each piston and rod assembly out top of cylinder bore. **NOTE** - Be careful not to nick crankshaft journals. Install rod caps on mating rods.

Installation - 1) Oil piston rings and cylinder walls with light engine oil. Ensure that ring gaps are properly spaced on piston (see illustration) and install ring compressor on piston.

2) Insert rod and piston assembly into cylinder bore and guide rod over crankshaft journal. **NOTE** - Arrow on piston head should point towards front of engine. Tap piston into cylinder bore using a wooden handle, install rod cap and tighten. Repeat procedure for each piston assembly.

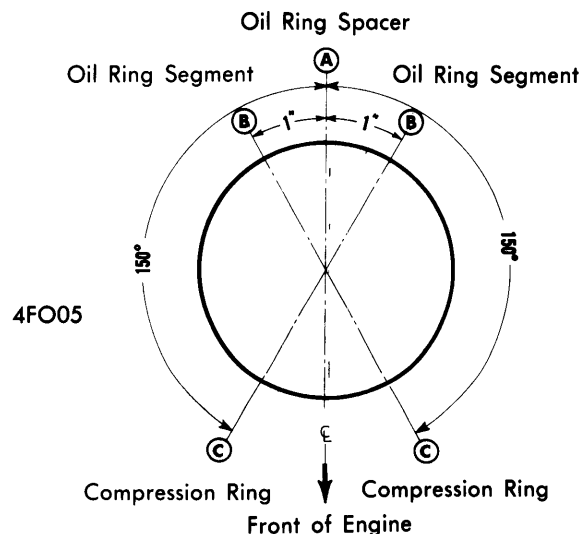

PISTON RING GAP SPACING

Ford 4 Engines

2000 CC & 2300 CC (Cont.)

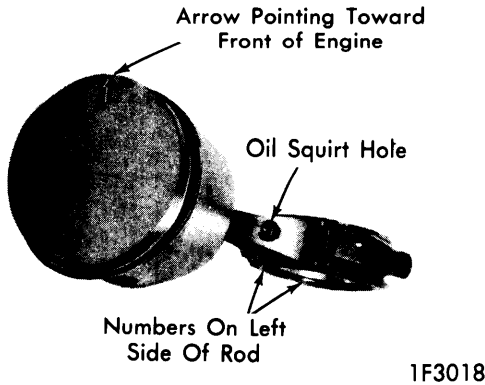

PISTON & ROD ASSEMBLY

FITTING PISTONS

Check piston to cylinder bore clearance by measuring the piston and bore diameters. Measure outer diameter of piston at centerline of piston pin bore and at 90° to pin bore axis. Oversize pistons are available.

PISTON PINS

Removal — Remove bearing inserts from connecting rod and cap. Mark pistons and pins to assure assembly with same rod. Press piston pin from piston and connecting rod.

Installation — Apply light coat of engine oil to all parts. Assemble piston to connecting rod with oil squirt hole (in connecting rod), and arrow (on top of piston), positioned as shown in illustration. Start piston pin in piston and connecting rod and press pin through piston and connecting rod until pin is centered in piston.

| CRANKSHAFT MAIN & CONNECTING ROD BEARINGS | | | | | | | |
|---|----------------|--------------|----------------|--------------------|-------------------------|--------------|--------------|
| Engine | MAIN BEARINGS | | | | CONNECTING ROD BEARINGS | | |
| | Journal Diam. | Clearance | Thrust Bearing | Crankshaft Endplay | Journal Diam. | Clearance | Sideplay |
| 2000 cc | 2.2432-2.2440" | .0006-.0016" | No. 3 | .003-.011" | 2.0464-2.0472" | .0006-.0015" | .004-.011" |
| 2300 cc | 2.3982-2.3990" | .0008-.0015" | No. 3 | .004-.008" | 2.0465-2.0472" | .0006-.0015" | .0008-.0026" |

MAIN & CONNECTING ROD BEARINGS

NOTE — Following procedures are with oil pan and oil pump removed.

Connecting Rod Bearings — After ensuring rod caps are marked for cylinder identification, remove rod caps. Use Plastigage method to check for proper bearing clearances. If not within specifications, new bearings must be installed. New bearings are available in .001" and .002" undersizes. Selective fitting is required on each connecting rod. A standard bearing may be used in combination with a .001" undersize, or a .002" undersize in combination with a .001" undersize. **NOTE** — Always replace bearings in pairs. Never use a new bearing in combination with a used bearing. Coat bearing surfaces with oil, install rod cap and tighten nuts.

Main Bearings — 1) Position jack under counterweight adjoining bearing being checked so weight of crankshaft will not compress Plastigage and provide an erroneous reading. With all bearing caps (other than one being checked) tight, check clearances using Plastigage method.

2) If clearances are excessive, a .001" or .002" undersize bearing may be used in combination with a standard bearing. If .002" undersize bearings are used on more than one journal, they must be positioned in cylinder block rather than bearing cap. **NOTE** — Always replace bearings in pairs. Never use a new bearing in combination with a used bearing. If standard and .002" undersize combination do not bring bearing clearance within specified limits, crankshaft will have to be refinished and undersized bearings installed.

3) Remove all upper main bearings by inserting suitable tool in oil hole of crankshaft journal and rotating crankshaft clockwise to roll bearing from engine. Oil new upper bearing and insert plain (unnotched) end between crankshaft and indented (or notched) side of block. Rotate bearing into place. Install all main bearing caps with arrows pointing to front of engine.

REAR MAIN BEARING OIL SEAL

2000 cc

Removal — Remove transmission, clutch and flywheel or automatic transmission converter and flywheel. Remove old seal using sheet metal screw (see illustration).

Installation — Using suitable tool (T71P-6701-A), drive new seal into place (see illustration).

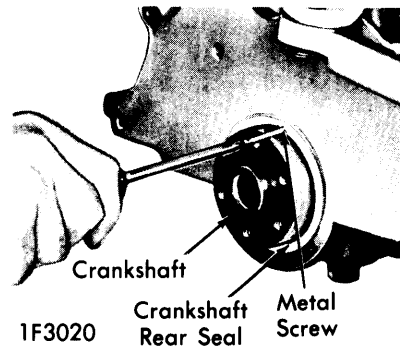

REMOVING REAR MAIN OIL SEAL

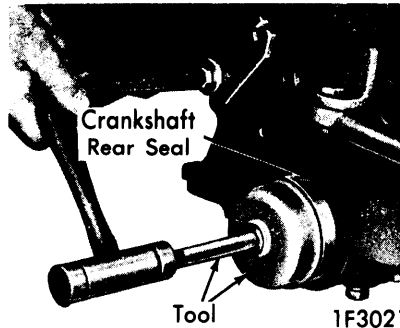

INSTALLING REAR MAIN OIL SEAL

2000 CC & 2300 CC (Cont.)

2300 CC

Removal & Installation — 1) Split lip type seal is provided for service replacement. Loosen all main bearing cap bolts, allowing crankshaft to drop (not more than $\frac{1}{32}$ ") and remove rear main bearing cap. Remove oil seal from cap and clean oil seal groove. Remove upper seal half from block using seal removal tool or small metal screw in end of seal. **CAUTION** — Extreme care should be taken not to scratch or mar crankshaft seal surface.

2) Dip new split lip type seal halves in clean engine oil. Carefully install upper seal into its groove with undercut side of seal toward front of engine, by rotating it on seal journal of crankshaft until approximately $\frac{3}{8}$ " protrudes below parting surface. **CAUTION** — Be sure no rubber has been shaved from outside diameter of seal. Tighten remaining bearing caps. Install lower seal in rear main bearing cap with undercut side of seal toward front of engine. Allow seal to protrude approximately $\frac{3}{8}$ " above parting surface to mate with upper seal. **NOTE** — Locating tab must face rear of engine. Apply suitable sealer to rear main bearing cap mating surfaces, taking care to not permit sealer on seal, install main bearing cap and tighten.

FRONT CRANKSHAFT OIL SEAL

Removal & Installation — Remove alternator belt and crankshaft pulley. Remove camshaft drive belt (see Camshaft Drive Belt). Remove drive belt sprocket and belt guide from crankshaft (if equipped). Use suitable tool (T71P-6160-A or Y74P-6700-B) to remove and replace oil seal.

| CAMSHAFT | | | |
|----------|----------------|-------------|-------------|
| Engine | Journal Diam. | Clearance | Lobe Lift ① |
| 2000 cc | | | |
| No. 1 | 1.6531-1.6539" | .001-.0025" | .2493" |
| No. 2 | 1.7563-1.7571" | | |
| No. 3 | 1.7713-1.7720" | | |
| 2300 cc | | .001-.0029" | .2437" |

① — End play is .001-.007".

CAMSHAFT DRIVE BELT

Removal & Installation — See Camshaft Timing.

CAMSHAFT

Removal — With cylinder head removed from engine, remove rocker arms. **NOTE** — Keep rocker arms in order for reinstallation in original position. Remove camshaft sprocket attaching bolt. Slide sprocket and belt guide plate from camshaft. Remove camshaft thrust plate from rear of cylinder head and carefully slide camshaft out rear of cylinder block.

Installation — Oil camshaft with engine oil and apply Lubriplate to valve stem tips. Oil rocker arms and carefully install camshaft in cylinder head. Install thrust plate, bolts and tighten. Check camshaft endplay and replace thrust plate if endplay not within specifications. **NOTE** — Use new camshaft attaching bolt or use new Teflon tape on threads of old bolt.

CAMSHAFT BEARINGS

Removal & Installation — Use suitable tool (71P-6250A) to remove and install bearings. **NOTE** — Lube hole in bearing must be aligned with oil hole in journal.

CAMSHAFT END THRUST

With camshaft drive belt cover removed, push camshaft toward rear of engine. Install dial indicator so indicator point is on camshaft sprocket attaching screw or gear hub and zero dial indicator. Using a large screwdriver between camshaft sprocket or gear and cylinder head, pull the camshaft forward and release it. Read dial indicator and if end play is not within specifications, replace thrust plate at rear of cylinder head.

CAM LOBE LIFT

Measure distance between major and minor diameters of each cam lobe with a micrometer. Difference in readings is lobe lift. If readings vary, or do not meet specifications, replace camshaft.

CAMSHAFT TIMING

Checking Timing (2000 cc) — Remove camshaft belt cover, air pump adjusting arm support bracket (if equipped) and camshaft sprocket attaching bolt. Position crankshaft on TDC. **CAUTION** — Rotate engine in clockwise direction only. Install suitable tool (T71P-8620-A) on engine with large pin inserted in camshaft sprocket bolt hole. Tool should be to left of thermostat housing. Rotate tool in clockwise direction until small pin can be inserted into large keyway near bottom of gear. **NOTE** — It may be necessary to turn crankshaft one full turn to bring keyway to bottom edge of sprocket. Bottom edge of tool should lie across belt (see illustration). Timing is incorrect if tool position is not as indicated.

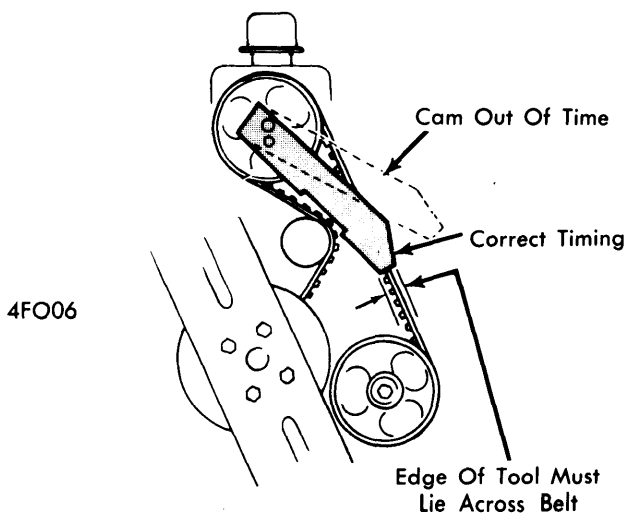

CHECKING CAMSHAFT TIMING — 2000 cc

Checking Timing (2300 cc) — Remove access plug from belt cover and position crankshaft to TDC by aligning pointer on cover with "O" mark on crankshaft damper. **NOTE** — Turn engine in direction of normal rotation only. Look through access hole and check that timing mark on cam drive sprocket is lined up with pointer on inner belt cover. Remove distributor cap and check that rotor is facing No. 1 position on cap.

Adjusting Timing (2000 cc) — 1) If timing is incorrect or it is necessary to remove belt, remove drive belt tensioner using a suitable tool (T71P-6603-A) and lift belt from sprockets. Ensure that crankshaft is at TDC and camshaft sprocket and dis-

Ford 4 Engines

2000 CC & 2300 CC (Cont.)

tributor are in correct positions as shown in illustration. Install belt tensioner, ensuring that one end of spring engages groove in anchor stud, which is behind pin of back plate.

2) Position drive belt on sprockets and with tensioner loose, rotate crankshaft two complete turns to remove slack from belt

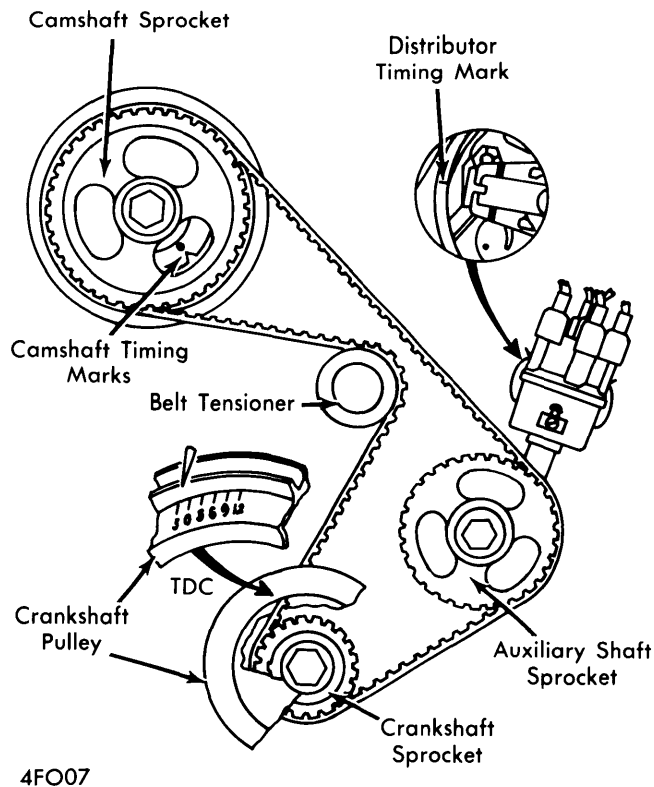

TIMING MARKS - 2000 cc & 2300 cc

and allow tensioner to move tight against belt. Tighten tensioner adjustment and pivot bolts. Recheck timing marks as previously described.

Adjusting Timing (2300 cc) - 1) If timing is incorrect or it is necessary to remove belt, remove timing belt outer cover and loosen belt tensioner adjustment screw. Position tension adjusting tool on tension spring roll pin and release belt tensioner. Tighten adjustment screw to hold tensioner in released position. Remove crankshaft damper, belt guide and drive belt.

2) Position crankshaft sprocket and camshaft sprocket as shown in illustration. Remove distributor cap and set rotor to No. 1 firing position by turning auxiliary shaft. Install drive belt over crankshaft sprocket and then counterclockwise over auxiliary and camshaft sprockets. Align belt fore and aft on sprockets.

3) Loosen tensioner adjustment screw and allow tensioner to move against drive belt. Remove spark plugs and rotate crankshaft two complete turns in direction of normal rotation to remove slack from belt. Tighten tensioner adjustment and pivot bolts. Recheck timing mark alignment.

AUXILIARY SHAFT

Removal - Remove drive belt cover, drive belt and auxiliary sprocket retaining bolt and washer. Slide sprocket from auxiliary shaft. Remove distributor, fuel pump and auxiliary shaft cover. Remove thrust plate and carefully remove shaft from cylinder block. Remove bearing from block, if worn or damaged, using suitable tool.

Installation - Align oil holes in bearing with those in block and drive bearing into place using a suitable tool. Oil shaft with engine oil and slide into cylinder block. **CAUTION** - Do not allow gear and fuel pump eccentric to touch bearing surfaces during installation. Install thrust plate, gasket and shaft cover, fuel pump, distributor and sprocket. Install and adjust drive belt. Install drive belt cover.

ENGINE OILING

Crankcase Capacity - 4 quarts. Add 1 quart with filter change.

Oil Filter - Replace at first oil change and every second oil change after that.

Normal Oil Pressure (Hot) - 45-65 psi @ 2000 RPM (2000 cc engine). 40-60 psi @ 2000 RPM (2300 cc engine).

Pressure Regulator Valve - In pump body. Not adjustable.

ENGINE OILING SYSTEM

Oiling system is force feed type using a full flow oil filter. Oil enters main oil gallery from the oil filter and flows to main bearings and camshaft bearings. Connecting rod bearings are supplied from front and rear main bearings via inclined passages. A squirt hole in each rod bearing end supplies oil to piston thrust side of a cylinder. The auxiliary shaft is connected with the main oil gallery.

The distributor shaft receives oil from a passage drilled in the auxiliary shaft. Cam and cam follower arms are supplied from

camshaft bearings and valve lash adjusters are oiled from drilled oil passages in cylinder head.

OIL PUMP

NOTE - On 2300 cc engines, remove oil pump and cover. Check clearances and if not within specifications, replace oil pump. Do not disassemble oil pump.

Removal & Disassembly - Remove oil pan and separate pick-up tube and screen from body of oil pump. Remove oil pump attaching bolts. Remove three cover attaching screws and remove cover. Lift rotor assembly from housing.

Inspection & Assembly - Clean, inspect and oil all parts thoroughly (see specifications for clearances). Install outer race and inner rotor and shaft assembly. **NOTE** - Identification mark on rotor and on outer race both face to bottom of pump. Inner rotor and shaft, and outer race are serviced as an assembly. Install cover and bolts. Position a new gasket and oil inlet tube on oil pump and install attaching bolts.

2000 CC & 2300 CC (Cont.)

ENGINE OILING (Cont.)

Oil Pump Specifications

| | |
|---|------------------------|
| Relief Valve Spring Tension | |
| 2000 cc..... | 13.6-14.7 Lbs. @ 1.39" |
| 2300 cc..... | 7.54-8.34 Lbs. @ 1.53" |
| Drive Shaft to Bearing Clearance | |
| 2000 cc..... | .001-.002" |
| 2300 cc..... | .0015-.0029" |
| Relief Valve Clearance | |
| 2000 cc..... | .001-.002" |
| 2300 cc..... | .0015-.0029" |
| Rotor Assembly End Clearance | |
| 2000 cc & 2300 cc..... | .001-.004" |
| Outer Race to Housing (Radial) | |
| 2000 cc..... | .005-.011" |
| 2300 cc..... | .001-.007" |

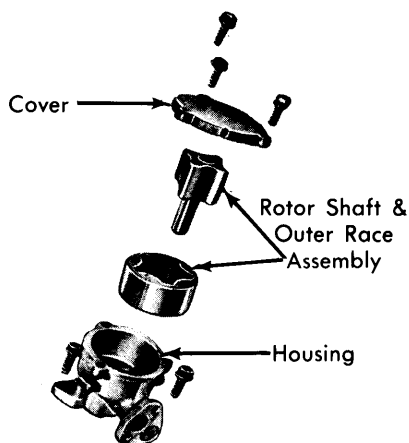

4FO08

OIL PUMP - DISASSEMBLED

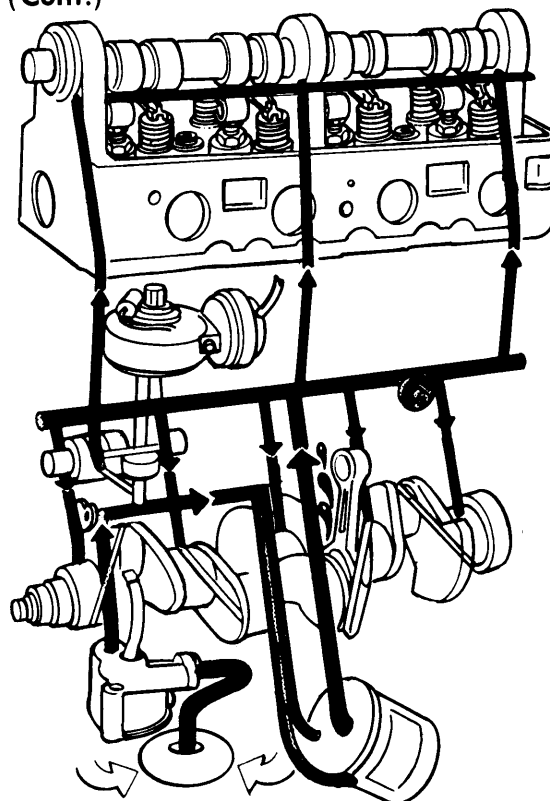

3AM3009

ENGINE OILING SYSTEM

TIGHTENING SPECIFICATIONS

| Application | 2000 cc Ft. Lbs. | 2300 cc Ft. Lbs. |
|---|---------------------|---------------------|
| Auxiliary Shaft Sprocket | 32-36 | 28-40 |
| Auxiliary Shaft Thrust Plate | 5-8 | 6-9 |
| Belt Tensioner Bolt | 32-36 | ① 28-40 |
| Camshaft Sprocket | 32-36 | 50-71 |
| Camshaft Thrust Plate | 5-8 | 6-9 |
| Connecting Rod | 29-34 | 30-36 |
| Crankshaft Damper Or Pulley..... | 39-43 | 80-114 |
| Cylinder Head | ② 65-80 | ③ 80-90 |
| Exhaust Manifold-to-Cylinder Head | 15-18 | ④ 16-23 |
| Flywheel-to-Crankshaft..... | 47-51 | 54-64 |
| Front Cover..... | 6-9 | |
| Fuel Pump | 12-15 | 14-21 |
| Intake Manifold | 12-15 | ④ 14-21 |
| Main Bearing Caps | 65-75 | ③ 80-90 |
| Oil Pan | 4-6 | 6-8 |
| Rocker Arm Ball Stud Nut..... | 32-36 | |
| Timing Belt Cover | 5-7 | 6-9 |

- ① - Specification is for pivot bolt. Adjustment bolt torque is 14-21 ft. lbs.
- ② - Tighten in three steps as follows: Step 1 - 14-29 ft. lbs. Step 2 - 36-50 ft. lbs. Step 3 - 65-80 ft. lbs.
- ③ - Tighten in two steps as follows: Step 1 - 60 ft. lbs. Step 2 - 80-90 ft. lbs.
- ④ - Tighten in two steps as follows: Step 1 - 8 ft. lbs. Step 2 - 16-23 ft. lbs.