

Chrysler Corp. V8 Engines

GENERAL SPECIFICATIONS						
Engine	Net HP At RPM	Torque (Ft. Lbs. at RPM)	Compr. Ratio	Bore	Stroke	Displ. Cu. Ins.
318" 2-Bbl.	150 @ 4000	225 @ 2200	8.6-1	3.91"	3.31"	318"
318" 2-Bbl.	170 @ 4000	265 @ 2200	8.6-1	3.91"	3.31"	318"
318" 2-Bbl.	150 @ 4000	255 @ 2200	8.6-1	3.91"	3.31"	318"
360" 2-Bbl.	180 @ 4000	290 @ 2400	8.4-1	4.00"	3.58"	360"
360" 4-Bbl.	200 @ 4000	290 @ 3200	8.4-1	4.00"	3.58"	360"
360" 4-Bbl.	245 @ 4800	320 @ 3600	8.4-1	4.00"	3.58"	360"
400" 2-Bbl.	185 @ 4000	315 @ 2400	8.2-1	4.32"	3.375"	400"
400" 4-Bbl.	205 @ 4400	310 @ 2400	8.2-1	4.32"	3.375"	400"
400" 4-Bbl.	240 @ 4800	320 @ 3200	8.2-1	4.32"	3.375"	400"
400" 4-Bbl.	250 @ 4800	330 @ 3400	8.2-1	4.32"	3.375"	400"
440" 4-Bbl.	230 @ 4000	350 @ 3200	8.2-1	4.32"	3.75"	440"
440" 4-Bbl.	250 @ 4000	350 @ 3200	8.2-1	4.32"	3.75"	440"
440" 4-Bbl.	275 @ 4400	375 @ 3200	8.2-1	4.32"	3.75"	440"

NOTE — Horsepower and Torque figures given above are NET. Net Horsepower and Torque represents power at the flywheel when the engine is installed in a vehicle, with wide open throttle and all systems operating such as; air cleaner, exhaust system, water pump, generator, oil pump and air conditioning.

ENGINE IDENTIFICATION

Engine identification number locations are as follows: 318" and 360" on left front of block below cylinder head; 400" and 440" on cylinder block just forward of number two cylinder bore and adjacent to distributor. Number is decoded as follows on 318" and 360":

JM318R51362579

First Digit — Model Year.

Second Digit — Manufacturing Plant Code.

Third, Fourth & Fifth Digits — Engine Displacement.

Sixth Digit (And Seventh When Used) — Engine Model.

R — Regular Fuel

LC — Low Compression

S — Special Engine

HP — High Performance

Following Four Digits — Build Date Code.

Remaining Digits — Sequence Built Number.

Number is decoded as follows for 400" and 440" engines:

J440R83222

First Digit — Model Year.

Second, Third & Fourth Digits — Engine Displacement.

Fifth Digits (And Sixth When Used) — Engine Model.

R — Regular Fuel

LC — Low Compression

S — Special Engine

HP — High Performance

Following Four Digits — Build Date Code.

Remaining Digit — Shift Built

SPECIAL ENGINE MARKS		
Code	Location	Identification
"Maltese Cross"	Engine No. Pad	.001" undersize crankshaft journals.
"R" or "M"	Crankshaft Ⓢ	
"Maltese Cross and X"	Engine No. Pad	.010" undersize crankshaft journals.
"RX" or "MX"	Crankshaft Ⓢ	
"A"	Engine No. Pad	.020" oversize cylinder bores.
"Ⓢ"	Engine No. Pad	.008" oversize tappet bodies.
"X" or "O/S"	End of Cylinder Head	.005" oversize valve stems.
"LC"	Model Pad	Low Compression
"HP"	Model Pad	High Performance
"SP"	Model Pad	Special Police
"E"	Engine No. Pad	Cast crankshaft.

Ⓢ — Milled flat on crankshaft counterweight.

NOTE — Number following code "R" or "M" indicates specific journal undersized.

ENGINE REMOVAL

All Models — After scribing outline of hinge brackets on hood to assure proper alignment when reinstalling, remove hood, drain cooling system, remove battery and air cleaner. Then proceed as follows:

1) Remove all hoses, fan shroud, oil cooler lines and radiator. Disconnect fuel lines, all linkage, electrical wires and controls attached to engine.

2) Discharge air conditioning if equipped. Remove air conditioning hoses and power steering hoses, if equipped. Remove starter, alternator, charcoal canister and horns.

3) Raise vehicle on hoist and remove exhaust pipe at manifold. Remove bell housing bolts and inspection plate. Remove torque converter drive plate bolts, mark converter and drive plate to aid in reassembly. Support transmission with suitable stand (C-3201A) to ensure that converter will remain in proper position in transmission housing.

4) Lower vehicle and attach engine lifting fixture to cylinder head and support engine with chain hoist. Remove engine front mount bolts and lift engine from vehicle.

INTAKE MANIFOLD

Removal - 1) Drain cooling system and disconnect upper radiator hose, by-pass hose and heater hoses. Disconnect battery ground and remove alternator, air cleaner and fuel line to carburetor.

2) Disconnect accelerator linkage, coil wires and temperature sending unit wire. Remove distributor cap, wires and vacuum hose.

3) On 400" and 440" engines, disconnect diverter valve vacuum line from intake manifold, air pump line at exhaust manifolds and diverter valve on the high mounted air pump (if equipped). Do not remove the low mounted air pump.

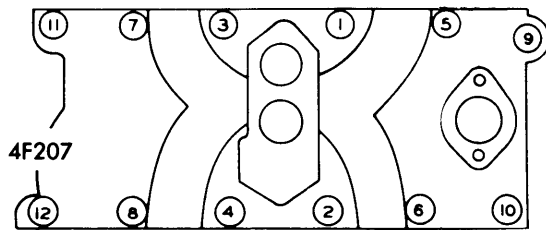

318" & 360" ENGINE INTAKE MANIFOLD TIGHTENING SEQUENCE

4) Remove closed ventilation system, evaporation control system and rocker covers.

5) Remove intake manifold bolts and remove intake manifold, coil and carburetor as an assembly.

Installation (318" & 360") - Coat intake manifold side gaskets with gasket sealer on 318" engines. On 360" engines, do not use sealer on side composition gaskets. Position side

and end gaskets in place on cylinder block and carefully lower intake manifold into position. Install cap screws finger tight. Tighten screws in sequence (see illustration) in two steps.

Installation (400" & 440") - Install intake manifold, carburetor and coil as an assembly. Tighten manifold bolts in two steps.

CYLINDER HEAD

Removal - Remove intake manifold and exhaust manifold. Remove rocker arm and shaft assemblies. Remove push rods and identify them to insure installation in original location. Remove spark plugs and tappet chamber cover on 400" and 440" engines. Remove cylinder head bolts. Remove cylinder heads and gaskets.

Installation - Coat new gasket lightly with suitable sealer and install gaskets and cylinder heads. Install cylinder head bolts and tighten head bolts, in two steps, to specifications. See illustrations for tightening sequence.

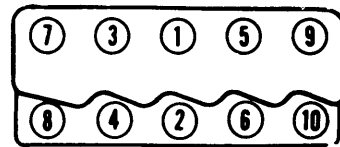

318" & 360" CYLINDER HEAD TIGHTENING SEQUENCE

2F253

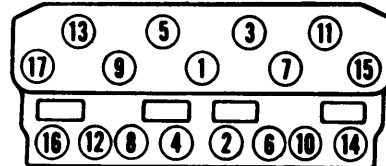

400" & 440" CYLINDER HEAD TIGHTENING SEQUENCE

2F254

VALVES							
Engine & Valve	Head Diam.	Face Angle	Seat Angle	Seat Width	Stem Diameter	Stem Clearance	Valve Lift
318" Int.	1.78"	45°	45°	.065-.085"	.372-.373"	.001-.003"	.373"
318" Exh.	1.50"	43°	45°	.040-.060"	.371-.372"	.002-.004"	.399"
360" Int.	1.88"	45°	45°	.065-.085"	.372-.373"	.001-.003"	.410"⑤
360" Exh.	1.60"	43°	45°	.040-.060"	.371-.372"	.002-.004"	.412"⑥
400" 2-Bbl.							
400" 4-Bbl. Std. Int.	2.08"	45°	45°	.060-.085"	.3723-.3730"	.001-.0027"	.434"
440" 4-Bbl. Std. Exh.	1.75"	45°	45°	.040-.060"	①	③	.430"
400" 4-Bbl. Int.	2.08"	45°	45°	.060-.085"	.3718-.3725"	.0015-.0032"	.450"
440" (High Perf.) Exh.	1.75"	45°	45°	.040-.060"	②	④	.464"

① - Hot End .3713-.3720". Cold End .3723-.3730".

② - Hot End .3708-.3715". Cold End .3718-.3725".

③ - Hot End .002-.0037". Cold End .001-.0027".

④ - Hot End .0025-.0042". Cold End .0015-.0032".

⑤ - .429" on 360" 4-Bbl. Int.

⑥ - .444" on 360" 4-Bbl. Exh.

VALVE ARRANGEMENT

All - E-I-I-E-E-I-I-E

VALVE GUIDE SERVICING

Wear Check - Remove valve springs and install suitable sleeve over valve stem and install valve in guide. Attach dial indicator to cylinder head and set it at right angle to valve stem being measured. Total sideplay should not exceed .017". If dial reading is excessive or stems are scuffed or scored, ream guides for installation of valves with oversize stems.

Servicing - Ream guides to next oversize valve stem. Oversize valve stems are available in .005", .015" and .030" sizes. **NOTE** - Do not attempt to ream guides from standard diameter to .030" oversize in one step. Use step procedure to obtain the .030".

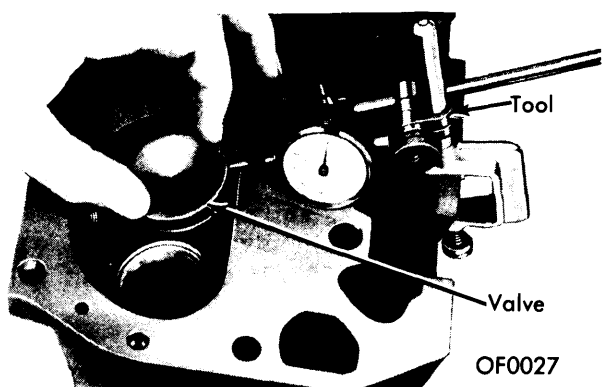

MEASURING VALVE GUIDE WEAR

VALVE STEM OIL SEALS

Cup type seals used on all valves. Coat valve stems with oil and insert in cylinder head. Press new seals squarely over valve guide using valve stem as a guide. Do not force seal against top of guide as the sealing lip pressure of the seal will be greatly reduced.

VALVE SPRINGS			
Engine	Free Length	PRESSURE (LBS.)	
		Valve Closed	Valve Open
318" & 360"	2.00"	78-88 @ 1 ¹ / ₁₆ "	170-184 @ 1 ¹ / ₁₆ "
400" 2-Bbl. 400" 4-Bbl. Std. 440" 4-Bbl.	2.58"	121-129 @ 1 ⁵ / ₆₄ "	192-208 @ 1 ¹ / ₁₆ "
400" 4-Bbl. 440" Hi. Perf.	2.23"	100-110 @ 1 ⁵ / ₆₄ "	236-256 @ 1 ³ / ₆₄ "

VALVE SPRINGS

Removal - With cylinder head removed, compress valve springs using a suitable tool (C-3422A). Remove valve retaining locks, retainers, cup seals and valve springs.

Installation - Reverse removal procedure and only compress spring enough to install the locks. Check valve spring height.

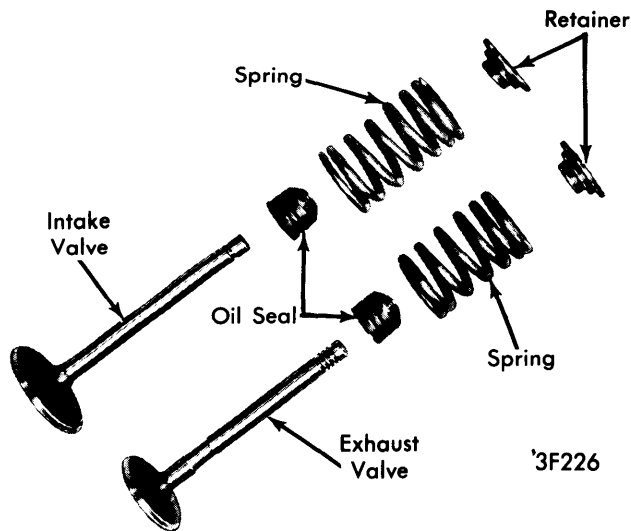

VALVE ASSEMBLIES

VALVE SPRING INSTALLED HEIGHT

Valve springs must be square within 1/16". Installed height of springs (measured from spring contact area on head to underside of spring retainer) should not exceed specifications. If height is greater than maximum allowable, install a 1/16" spacer(s) to bring spring height back to normal.

Valve Springs Installed Height

Engine	Minimum	Maximum
318" & 360"	1 ⁵ / ₈ "	1 ¹¹ / ₁₆ "
400" & 440"	1 ⁵³ / ₆₄ "	1 ⁵⁷ / ₆₄ "

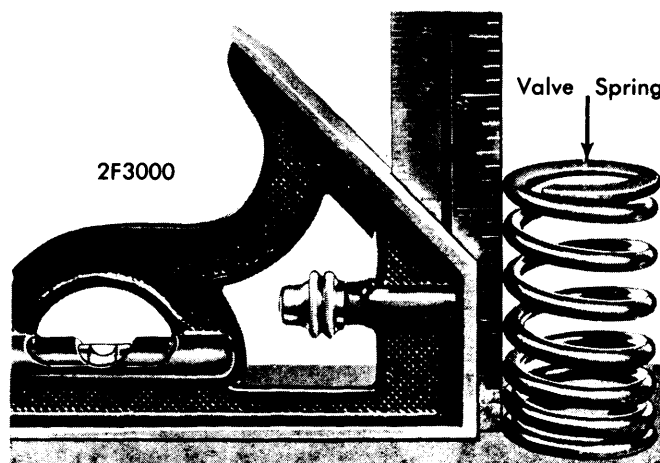

CHECKING VALVE SPRING SQUARENESS

ROCKER ARM ASSEMBLY

NOTE - Whenever rocker arm shaft assemblies are being installed, tighten support bracket bolts slowly and evenly in order that lifters have time to bleed down to operating length.

318" & 360" Engines - Notch on end of rocker shaft must face inward toward center of engine, and must point toward rear of engine on right bank and front of engine on left bank. Long stamped steel retainers go in number two and four positions.

400" & 440" Engines — Install rocker shafts with $\frac{3}{16}$ " lubrication holes pointing downward into the rocker arms and 15° angle of holes pointing outward toward valve end of rocker arm. **NOTE** — 15° angle of holes is determined from centerline of the bolt holes through the shaft which attaches shaft and bracket assembly to cylinder head. Long stamped steel retainers go in number two and four positions.

HYDRAULIC VALVE LIFTER ASSEMBLY

NOTE — Lifters are serviced as complete assemblies only. Parts are not interchangeable between lifters. If any component of lifter is worn or damaged, complete lifter must be replaced.

To test, remove cap from plunger (see illustration) and plunger from tappet body. Fill tappet body with clean kerosene and install plunger and cap. Place lifter upright in Lifter Testing Pliers and check leak down. If lifter collapses immediately, disassemble, clean and retest. If rapid leak down still occurs, replace lifter.

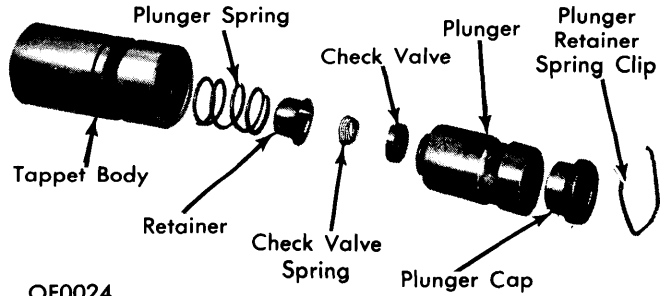

OF0024
HYDRAULIC VALVE LIFTER

HYDRAULIC VALVE LIFTER ADJUSTMENT

Lifters are set at zero lash. Clearance between valve stem tip and rocker arm pad with lifter fully collapsed is .060-.210" on all engines.

PISTONS, PINS, RINGS						
Engine	PISTONS		PINS		RINGS	
	① Clearance	Piston Fit	Rod Fit	Rings	End Gap	Side Clearance
318" & 360"	.0005-.0015"	.00025-.00075"	.0007-.0014"②	1&2 3	.010-.020" .015-.055"	.0015-.003" .0002-.005"
400" & 440"	.0003-.0013"	.00045-.00075"	.0007-.0012"②	1&2 3	.013-.023" .015-.055"	.0015-.003" .0000-.005"

① — Measured at Top of Piston Skirt.

② — Interference fit.

OIL PAN

Removal (318" & 360") — Disconnect negative battery cable, remove oil dipstick, raise car on hoist and proceed as follows:

1) Drain oil. Remove engine to torque converter left housing strut. Remove steering and idler arm ball joints from steering linkage center link.

2) Remove exhaust pipes from exhaust manifolds. Leave pipes hanging on single exhaust system. Remove oil pan bolts and oil pan. **NOTE** — On 360 H.P. 4-Bbl. raise front of engine 1 1/2 - 2" to remove oil pan in Satellite, Coronet and Charger models.

Removal (400" & 440") — Disconnect negative battery cable, remove oil dipstick, raise car on hoist and proceed as follows:

1) Disconnect steering linkage from idler arm and steering arm. Disconnect exhaust pipe branches from manifolds. Remove clamp attaching exhaust pipe to extension and remove exhaust pipe.

2) Drain crankcase oil and remove converter dust shield. Remove oil pan bolts. Turn flywheel until counterweight and connecting rods at front of crankshaft are at their highest position. Turn pan counterclockwise as it is lowered to clear oil screen and suction pipe. **NOTE** — On Satellite, Coronet and Charger models, raise front of engine 1 1/2 - 2" to remove oil pan.

Installation (All Engines) — Inspect alignment of oil strainer. Bottom of strainer must be parallel with the machined surface of cylinder block. The bottom of strainer must touch bottom of oil pan. Install oil pan bolts and tighten.

PISTON & ROD ASSEMBLY

NOTE — When removing or installing piston and connecting rod assemblies, rotate the crankshaft so connecting rod journal is on the center of cylinder bore.

Removal (All Engines) — Remove ridge at top of cylinder bores using suitable tool (C-3012) before removing pistons from block. **NOTE** — Keep tops of pistons covered during this procedure. Rotate crankshaft and inspect connecting rods and rod caps for cylinder identification. Identify them if necessary. Remove rod cap and push each piston and rod assembly out top of cylinder bore being careful not to nick crankshaft journals. Install rod caps on mating rods.

Installation — 1) Before installing piston and connecting rod assemblies into cylinder block, compression ring gaps must be staggered so neither is in line with oil ring rail gaps. The oil ring expander ends should be positioned under the notch on piston. Oil ring rail gaps should be facing middle of engine upon installation and spread 3" apart.

2) Immerse piston head and rings in clean engine oil and slide suitable ring compressor over piston and tighten. **NOTE** — Do not allow position of rings to change during ring compressor installation and tightening.

3) Rotate crankshaft so connecting rod journal is on center of cylinder bore. Insert rod and piston assembly into cylinder bore and guide rod over the crankshaft journal, taking care not to nick the journal **NOTE** — Notch on top of piston must face front of engine and larger chamfer of connecting rod bore must be installed toward crankshaft journal fillet.

4) Tap piston into cylinder bore using wooden handle of a hammer and guide connecting rod into place on crankshaft journal. Install rod cap and tighten. Repeat procedure for each piston assembly.

Chrysler Corp. V8 Engines

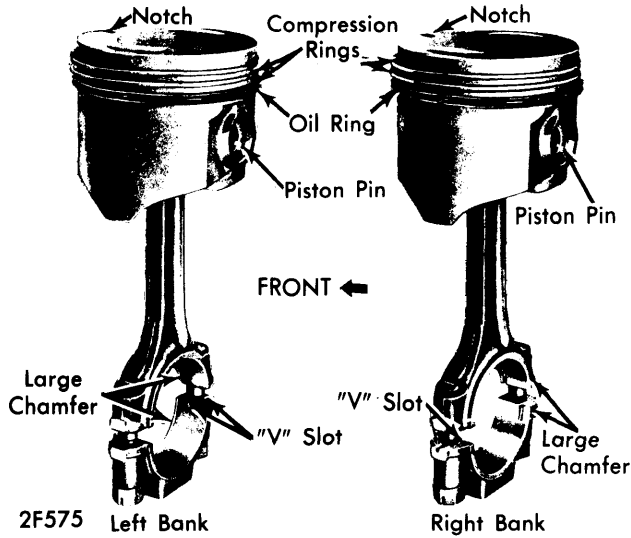

PISTON & ROD ASSEMBLY

FITTING PISTONS

Pistons should be measured 90° to piston pin axis at top of skirt. Measure cylinder bore halfway down the bore 90° to crankshaft center line. Pistons and cylinder bores should be measured at normal room temperature, 70°F.

PISTON PINS

Removal — Use suitable tool (C-4158 on 318" & 360" and C-3684 on 400" & 440") for piston pin removal. Install pilot on main screw (see illustration) and install screw through piston pin. Install anvil (with spring removed) over threaded end of main screw with small end of anvil against piston boss. Install nut loosely on main screw and place assembly on a press. Press piston pin out of connecting rod. Remove tool from piston.

Installation — 1) Lubricate piston pin holes in piston and connecting rod and use suitable tool to install pin. Install spring inside pilot and install spring and pilot in the anvil. Install piston pin over main screw.

2) Place piston (with front up) and connecting rod over pilot so pilot extends through piston pin holes. Assemble rods to pistons of the right cylinder bank (2,4,6 and 8) with indent on piston head opposite to larger chamfer on large bore end of connecting rod. Assemble rods to pistons of the left cylinder bank (1,3,5 & 7) with indent on piston head on the same side as the large chamfer on the large bore end of connecting rod.

3) Install main screw and piston pin in piston and install nut on main screw to hold assembly together. Place assembly in a vise. Press piston pin in until piston pin bottoms on the pilot.

Checking Pin Fit — Assemble suitable tool in the same manner as for piston pin removal and place assembly in a vise. Attach a torque wrench to nut and test torque to 15 ft. lbs. If connecting rod moves downward on the piston pin, reject connecting rod and piston pin combination. Install a new connecting rod and recheck. If connecting rod does not move under 15 ft. lbs. torque, piston pin fit is satisfactory.

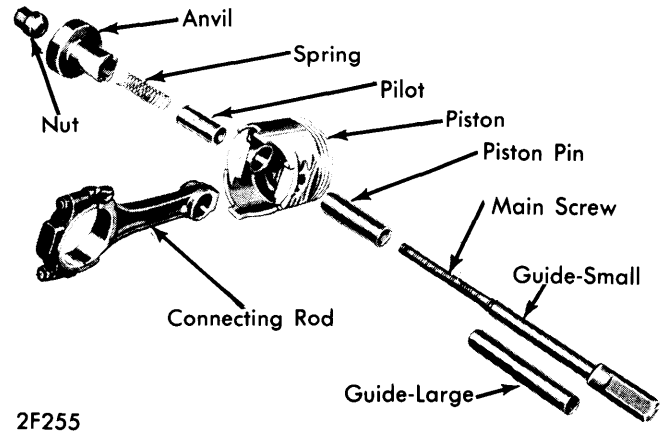

PISTON PIN INSTALLATION

CRANKSHAFT MAIN & CONNECTING ROD BEARINGS							
Engine	MAIN BEARINGS				CONNECTING ROD BEARINGS		
	Journal Diam.	Clearance	Thrust Bearing	Crankshaft Endplay	Journal Diam.	Clearance	Ⓢ Sideplay
318"	2.4995-2.5005"	.0005-.0020"	No. 3	.002-.007"	2.124-2.125"	.0005-.0020"	.006-.014"
360"	2.8095-2.8105"	.0005-.0020"	No. 3	.002-.007"	2.124-2.125"	.0005-.0020"	.006-.014"
400"	2.6245-2.6255"	.0005-.0020"	No. 3	.002-.007"	2.374-2.375"	Ⓣ .0005-.0020"	.009-.017"
440"	2.7495-2.7505"	.0005-.0020"	No. 3	.002-.007"	2.374-2.375"	.001-.0025"	.009-.017"

Ⓢ — Total, 2 rods. Ⓣ — Clearance shown is for 2-Bbl., 4-Bbl. is .001-.0025"

MAIN & CONNECTING ROD BEARINGS

NOTE — Following procedures are with oil pan and oil pump removed.

Connecting Rod Bearings — 1) After ensuring rod caps are marked for cylinder identification, remove rod caps. Smooth edges of a 1/2" by 3/4" piece of brass shim stock .002" thick (except for 318" and 400" 2-Bbl., thickness is .001"). Oil and

place between bearing and connecting rod journal. Install bearing cap and tighten. Rotate crankshaft 1/4 turn in each direction (Shim Stock Method for checking clearances). If a slight drag is felt, clearance is within limits. If no drag is felt, clearance is excessive. If crankshaft cannot be rotated, clearance is not enough.

2) New bearings are available in standard, .001", .002", .003", .010" and .012" undersize. Always install bearings in pairs. Do not use a new bearing with an old bearing. Install

connecting rod bearings so formed tang fits into machined groove in connecting rod. Install rod caps, with "V" groove of bearing matching "V" groove of cap, and tighten nuts.

Main Bearings - 1) Use Shim Stock Method (thickness of shim .001" on all engines) and check main bearing clearances, one at a time while all other main bearing caps are tight. New bearings are available in standard, .001", .002", .003", .010" and .012" undersize. A new .001" bearing half may be used in combination with a new standard bearing half or a .002" with a .001". **NOTE** - Always use smaller diameter bearing half as upper.

2) If bearing clearances are not within limits, remove bearing cap, insert suitable tool (C-3509) in oil hole journal and rotate crankshaft clockwise to remove upper bearing half. To install new upper bearing, slightly chamfer sharp edges from plain side and start bearing in place. Insert tool and slowly rotate crankshaft counterclockwise, sliding bearing in place. Install main bearing cap with new bearing installed and tighten. **NOTE** - Upper main bearings are grooved and lower main bearings are plain. Upper and lower are not interchangeable.

3) Check crankshaft end play and if not within specifications, change number three main bearing. This bearing carries thrust load.

REAR MAIN BEARING OIL SEAL

Removal - With oil pan removed, remove rear seal retainer and rear main bearing cap. Remove upper seal by turning suitable tool (C-4148) into end of seal and pulling seal out with tool, (do not mar crankshaft). Remove lower seal by carefully prying from the side with small screwdriver.

Installation - Split type rubber seals may be replaced without removing the crankshaft and must be installed as a pair. Oil upper seal lip lightly with engine oil. Hold seal (with paint stripe to rear) tightly against crankshaft with a thumb and rotate crankshaft while sliding seal into groove. **CAUTION** - Sharp edge of groove in block may shave or nick back of seal. Care must be exercised not to damage sealing lip. Install lower half of seal into lower seal retainer with paint stripe to rear. Install main bearing cap and tighten. Install lower seal retainer and tighten.

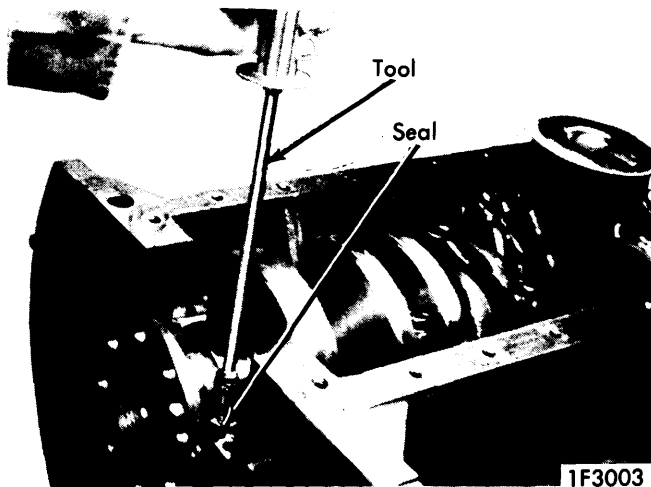

USING TOOL ON UPPER REAR MAIN OIL SEAL

ENGINE FRONT COVER

Removal - 1) Drain cooling system and remove radiator and water pump assembly. On 318" and 360" engines, also remove power steering pump, if equipped. Remove vibration damper bolt and using suitable tool (C-3688) pull damper assembly from end of crankshaft.

2) On 318" and 360" engines, remove fuel lines, fuel pump, loosen oil pan bolts and remove front bolt at each side. Then on all engines, remove cover bolts and cover. **NOTE** - Use extreme caution to avoid damaging oil pan gasket on 318" and 360" engines.

Installation - Check that mating surfaces of chain case cover and cylinder block are clean and free from burrs. Install cover with new gasket and tighten bolts. Tighten oil pan bolts and install fuel pump, lines and power steering pump on 318" and 360" engines. On all engines, install vibration damper, water pump assembly and radiator. Fill cooling system.

FRONT COVER OIL SEAL

Removal - With front cover removed, use a drift and hammer to tap lightly around seal case to form oil seal case inward. Grasp seal case with vise grips; twist and pull at several positions on seal case to remove seal.

Installation - Using suitable tool (C-3506) insert installing screw through the installing plate. Insert screw with plate through seal opening (with inside of cover facing up) and place seal in position with seal lips down. Place seal installing plate into seal with protective recess toward lip of seal retainer. Install flat washer and nut on installing screw. Hold screw and tighten nut. Seal is properly installed when seal case is tight against face of cover. If a .0015" feeler gauge cannot be inserted between neoprene and cover, seal is properly installed.

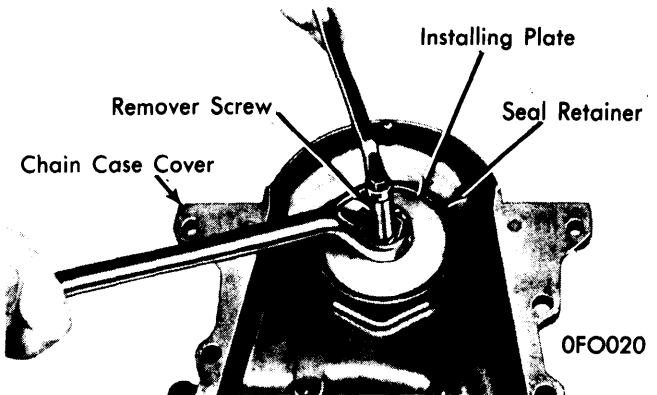

INSTALLING FRONT COVER OIL SEAL

CAMSHAFT			
Engine	Journal Diam.	Clearance ①	Lobe Lift
All Engines		.001-.003"
No. 1	1.998-1.999"		
2	1.982-1.983"		
3	1.967-1.968"		
4	1.951-1.952"		
② - 5	1.5605-1.5615"		

① - Wear limit - .005"

② - 400", 440" Engines 1.748-1.749".

TIMING CHAIN

Removal — With front cover removed, remove camshaft sprocket attaching bolt, washer and fuel pump eccentric (318" and 360" engines only). Remove timing chain with crankshaft and camshaft sprockets.

Installation — When installing timing chain, use a suitable tool (C-3509) to prevent camshaft from contacting welch plug in rear of engine block. Remove distributor and oil pump-distributor drive gear. Locate tool against rear side of cam gear and attach tool with distributor retainer plate bolt. Then proceed as follows:

1) Place camshaft and crankshaft sprockets on bench with timing marks on imaginary centerline through bore of both sprockets. Place timing chain around both sprockets. Turn crankshaft and camshaft to line up with keyway location in crankshaft sprocket and camshaft sprocket (dowel hole in camshaft sprocket on 400" and 440" engines).

2) Slide both sprockets evenly over their respective shafts (with new chain installed on sprockets). Use a straight edge to measure alignment of timing marks. Install washer and camshaft sprocket both and tighten. Check that rear face of aluminum camshaft sprocket is flush with end of camshaft.

CAMSHAFT

NOTE — Whenever a new camshaft is installed, inspect and check, with a straight edge, all tappet faces for "dishing". Replace any tappet with a negative crown.

Removal — With engine removed from vehicle, remove rocker arm and shaft assemblies: push rods and tappets; timing chain and sprockets; distributor with drive shaft. On 318" and 360" engines, remove camshaft thrust plate noting location of oil tab. On 400" and 440" engines, remove fuel pump and allow fuel pump push rod to drop away from cam. Install a long bolt in front of camshaft to facilitate removal and carefully remove camshaft.

Installation — Lubricate camshaft lobes and bearing journals. Insert camshaft to within 2" of its final position in cylinder block. Install suitable tool (C-3509) in distributor drive hole and hold in position using distributor lock plate screw. **NOTE** — Tool will prevent camshaft from being pushed in too far and knocking out camshaft rear plug. Install camshaft to proper position.

CAMSHAFT BEARINGS

Removal — Drive out welch plug at rear of block. With suitable driver-installer tool, use proper adapter on tool and drive out old bearings.

Installation — Using correct size adapter on tool, slide new rear bearing over adapter and carefully drive bearing into place. Install remaining bearings in same manner. Oil holes in new bearings must be aligned with oil passages from main bearings. Bearing oil hole index may be checked by inserting a pencil flashlight in the bearing. If oil holes are not in exact alignment, remove bearing and reinstall correctly. Install new welch plug at rear of cylinder block. **NOTE** — On 400" and 440" engines, install No. 1 bearing $\frac{1}{32}$ " inward from front face of cylinder block.

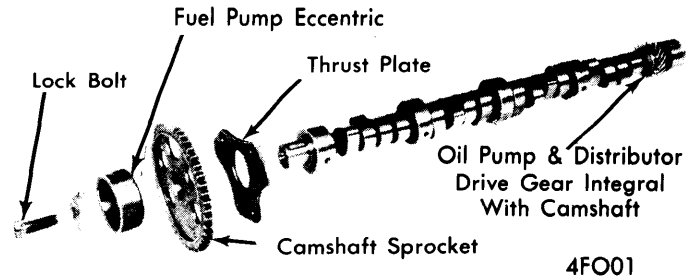
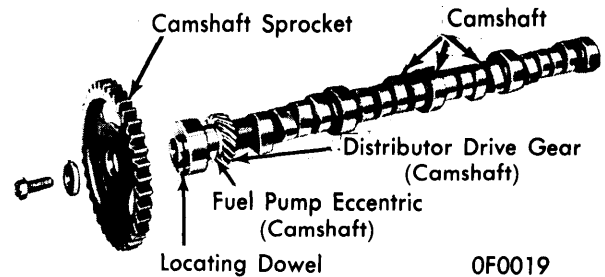
**318" & 360" ENGINE CAMSHAFT****400" & 440" ENGINE CAMSHAFT****CAMSHAFT END THRUST**

318" & 360" Engines — Taken by thrust plate behind camshaft sprocket. End play is .002-.006" (wear limit .010").

400" & 440" Engines — Taken by rear face of aluminum camshaft sprocket hub, bearing directly on front of cylinder block.

VALVE TIMING

Engine	INTAKE		EXHAUST	
	Open (BTDC)	Close (ABDC)	Open (BBDC)	Close (ATDC)
318"	10°	50°	52°	16°
360" 2-Bbl.	16°	56°	60°	16°
360 4-Bbl.	22°	66°	74°	22°
400" 2-Bbl. & 440" 4-Bbl. Std.	18°	62°	68°	20°
400" 4-Bbl. & 440" Hi. Perf.	21°	67°	79°	25°

VALVE TIMING**318" & 360"**

1) Turn crankshaft clockwise until No. 6 exhaust valve is closing and No. 6 intake valve is opening. Insert $\frac{1}{4}$ " spacer between rocker arm and valve stem of No. 1 intake valve. Spring load will bleed tappet down to effect solid tappet lash.

2) Install dial indicator so plunger contacts valve spring retainer in a perpendicular position. Zero indicator. Turn crankshaft clockwise until valve has lifted .010" for 318" engine, .020" for 360" engine with standard cam or .030" for

360" engine with 4-Bbl. and H.P. cam. **CAUTION** — Do not turn crankshaft any further. Valve spring may bottom and result in damage to rocker arm or push rod.

3) Timing mark on crankshaft pulley should read from 10° BTDC to 2° ATDC. If reading is not correct, check sprocket index marks, inspect timing chain for wear and check accuracy of DC mark on timing indicator.

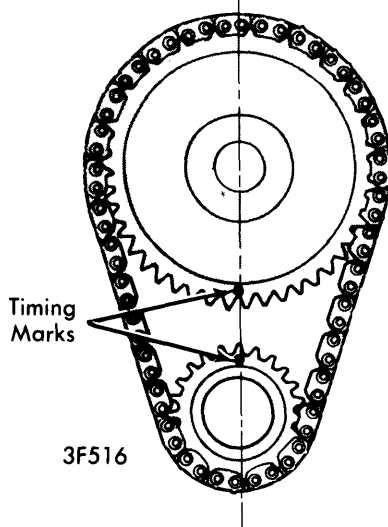

TIMING CHAIN SPROCKET ALIGNMENT

400" & 440"

1) Turn crankshaft clockwise until No. 6 exhaust valve is closing and No. 6 intake valve is opening. Insert 1/4" spacer between rocker arm and valve stem of No. 1 intake valve. Spring load will bleed tappet down to effect solid tappet lash.

2) Install dial indicator so plunger contacts valve spring retainer in a perpendicular position. Zero indicator. Turn crankshaft clockwise until valve has lifted .025" (400" 2-Bbl. and 440" Std.) or .033" (400" 4-Bbl. and 440" H.P.). **CAUTION** — Do not turn crankshaft any further. Valve spring may bottom and result in damage to rocker arm or push rod.

3) Timing mark on crankshaft pulley should read from 10° BTDC to 2° ATDC. If reading is not correct, check DC mark on timing indicator, sprocket index marks, timing chain for wear.

ENGINE OILING

Crankcase Capacity — 4 quarts. Add 1 quart with filter change.

Normal Oil Pressure — 30-80 psi at 2000 RPM.

Oil Filter — Change at first oil change and every second oil change after that.

Pressure Regulator Valve — In oil pump. Not adjustable.

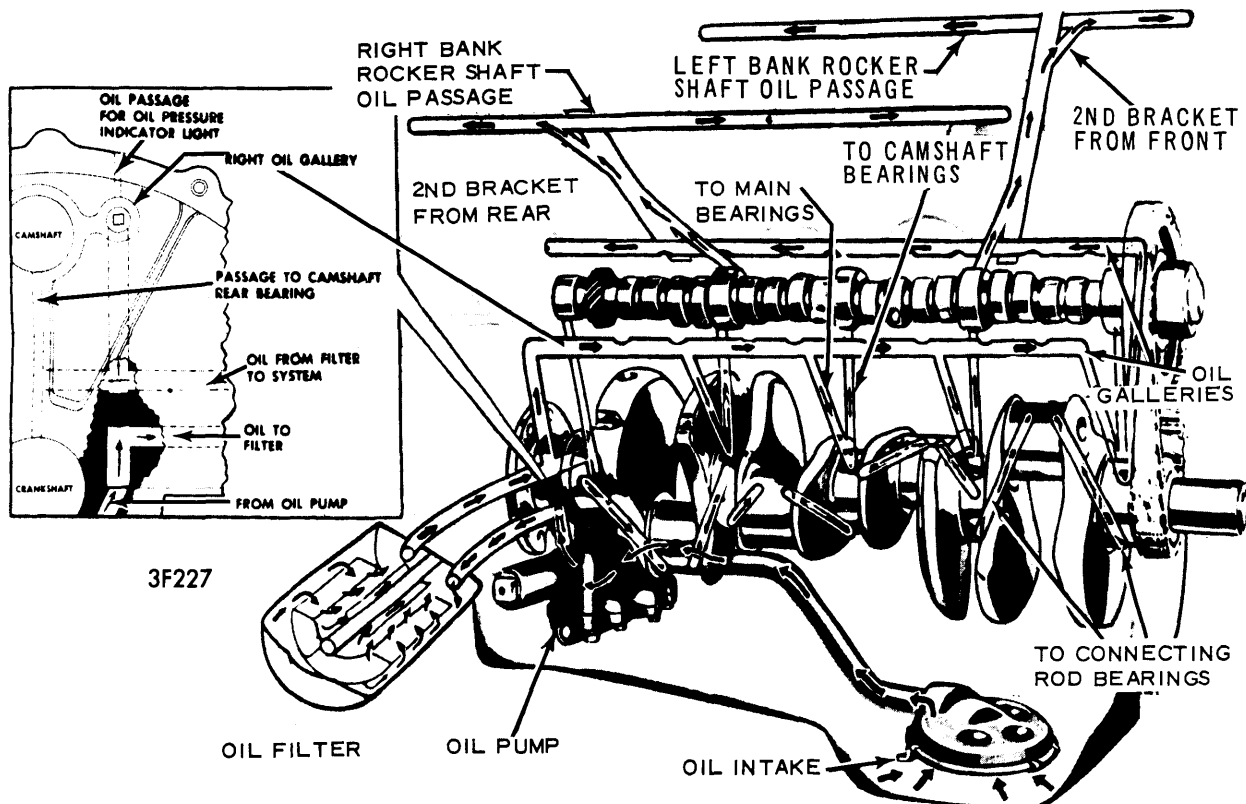

318" & 360" ENGINE OILING SYSTEM

Chrysler Corp. V8 Engines

ENGINE OILING (Cont.)

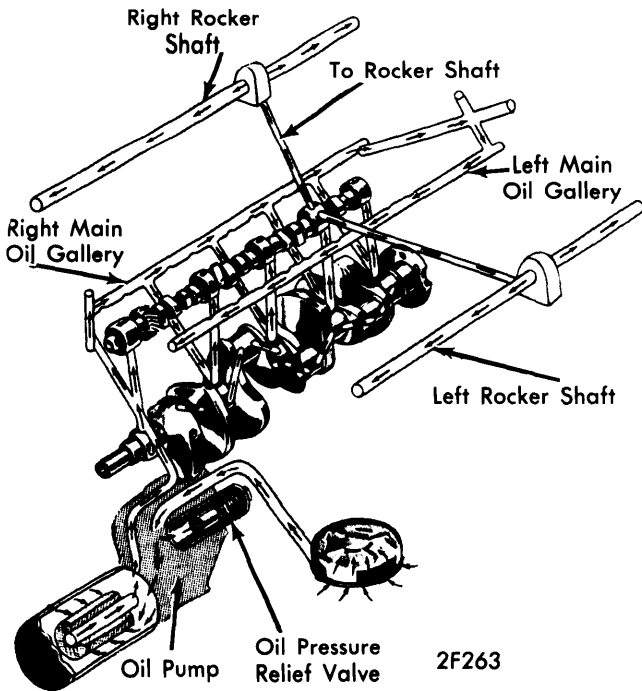

400" & 440" ENGINE OILING SYSTEM

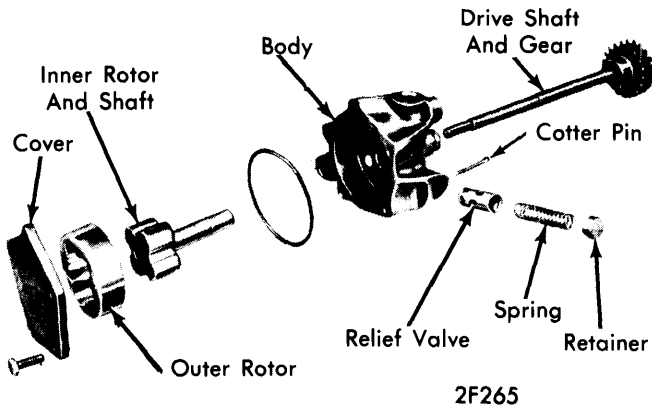

318" & 360" ENGINE OIL PUMP

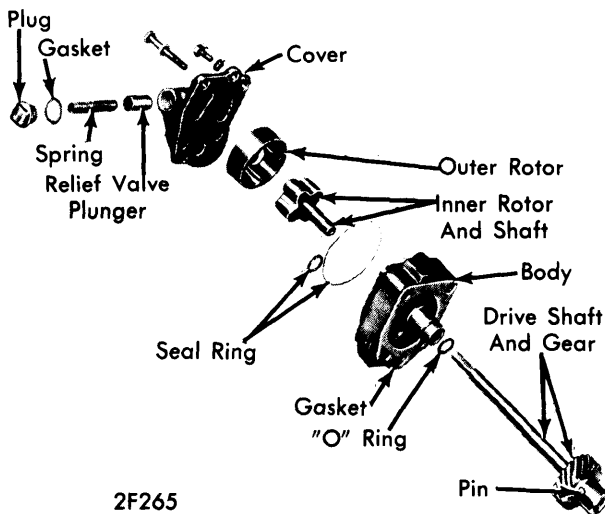

400" & 440" ENGINE OIL PUMP

OIL PUMP

Disassemble (see illustrations), clean and inspect all parts for proper clearances (see specifications). **NOTE** - Inner rotor and shaft assembly can only be replaced if outer rotor is replaced as units are a matched assembly.

Oil Pump Specifications

Application	318",360"	400",440"
Oil Pump Cover	.0015" Max.	.0015" Max.
Outer Rotor Length	.825" Min.	.943" Min.
Outer Rotor Dia.	2.469" Min.	2.469" Min.
Inner Rotor Length	.825" Min.	.942" Min.
Clear. Over Rotors (Outer)	.004" Max.	.004" Max.
Clear. Over Rotors (Inner)	.004" Max.	.004" Max.
Outer Rotor Clear	.014" Max.	.014" Max.
Tip Clear. Between Rotors	.010" Max.	.010" Max.

Pressure Relief Valve Springs

318" & 360" Engines - Spring has free length of $2\frac{1}{32}$ - $2\frac{3}{64}$ ". Spring should test 16.2-17.2 lbs. when compressed to $1\frac{11}{32}$ ".

400" & 440" Engines - Spring has free length of $2\frac{1}{4}$ ". Spring should test 22.3 to 23.3 lbs. when compressed to $1\frac{11}{32}$ ".

TIGHTENING SPECIFICATIONS

Application	318",360" Ft. Lbs.	400",440" Ft. Lbs.
Connecting Rod Cap	45	45
Cylinder Head	95	70
Main Bearing Cap	85	85
Camshaft Lock Bolt	35	50
Camshaft Thrust Plate	18	
Engine Front Cover	35	17
Crankshaft Bolt		
(Vibration Damper)	100	135
Rocker Arm Cover	(Inch Lbs.)40	(Inch Lbs.)40
Flywheel-to-Crankshaft	55	55
Flex Plate-to-Converter		
	(Inch Lbs.)270	(Inch Lbs.)270
Flywheel Housing-to-		
Cylinder Block 3/8"	30	30
7/16"	50	50
Intake Manifold	35	40
Oil Pan Screw	(Inch Lbs.)200	(Inch. Lbs.)200
Oil Pump Cover	8	10
Oil Pump-to-Mount	30	30
Rocker Arm Bracket Bolt	17	25
Water Pump-to-Housing	30	30
Water Pump or Housing-to-		
Cylinder Block	30	30
Exhaust Manifold Nut	15	30