

Chrysler Corp. 6 Engines

GENERAL SPECIFICATIONS						
Engine	Net HP At RPM	Torque (Ft. Lbs. at RPM)	Compr. Ratio	Bore	Stroke	Displ. Cu. Ins.
198" 1-Bbl.	95 @ 4000	145 @ 2000	8.4-1	3.40"	3.64"	198
225" 1-Bbl.	105 @ 3600	180 @ 1600	8.4-1	3.40"	4.125"	225

NOTE — Horsepower and Torque figures given above are NET. Net Horsepower and Torque represents power at the flywheel when the engine is installed in a vehicle, with wide open throttle and all systems operating such as; air cleaner, exhaust system, water pump, generator, oil pump and air conditioning.

ENGINE IDENTIFICATION

Engine number stamped on right side of block below No. 1 spark plug, contains following information:

H225R8222

First Digit (Letter) — Model Year

Second, Third & Fourth Digits (Numbers) — Engine Displacement

Fifth Digit (Letter) — Engine Model

Sixth, Seventh, Eighth & Ninth Digits (Numbers) — Build Date

Last Digit (Number) — Shift Built

SPECIAL ENGINE MARKS

Information identifying undersized crankshaft, oversized tappets, low compression and oversized cylinder bores is stamped on the cylinder block after the serial number.

L or LC — Low compression.

Maltese Cross — .001" undersize crankshaft journals. ("M" or "R", representing "main" or "rod" followed by the cylinder number of the journals concerned, will be found stamped on a crankshaft counterweight).

"A" — Indicates all cylinder bores .020" oversize.

"♦" — Indicates .008" oversize tappets.

"O/S" — Indicates .005" oversize valve stems.

ENGINE REMOVAL

All Models — After scribing outline of hinge brackets on hood to assure proper alignment when reinstalling, remove hood, drain cooling system, remove battery and air cleaner. Then proceed as follows:

1) Remove all hoses, fan shroud, oil cooler lines and radiator. Disconnect fuel lines, all linkage, wires and controls attached to engine.

2) Discharge air conditioning and remove hoses (if equipped). Remove starter, carburetor, alternator, charcoal canister, horns and power steering hoses (if equipped).

3) Raise vehicle on hoist and remove exhaust pipe at manifold. Remove bell housing bolts and inspection plate. Remove torque converter drive plate bolts and mark converter and drive plate to aid in reassembly. Support transmission with suitable stand (C-3201A) to ensure that converter will remain in proper position in transmission housing.

4) Lower vehicle and attach engine lifting fixture to cylinder head and support engine with chain hoist. Remove engine front mount bolts and lift engine from vehicle.

MANIFOLD ASSEMBLY

Removal — Disconnect all hoses and lines from air cleaner and remove air cleaner. Remove carburetor air heater and disconnect all lines and linkage to carburetor and remove carburetor. Disconnect exhaust pipe at manifold. Remove nuts and washers securing manifold assembly to cylinder head and remove manifold. Remove three screws securing intake manifold to exhaust manifold and separate manifolds.

Installation — Install new gasket between intake and exhaust manifold and install three screws securing manifolds together. Do not tighten screws at this time. Position manifold assembly on cylinder head using a new gasket. Install washers with cup side against manifold and snug all nuts. Tighten three intake to exhaust screws starting with inner screw. Start at center of manifold assembly and work outward, tightening manifold nuts. Reinstall carburetor, linkage, hoses and air cleaner.

CYLINDER HEAD

Removal — Drain cooling system and disconnect necessary wires, hoses and linkage. Remove manifold and carburetor as an assembly. Remove rocker arm and shaft assembly. Remove push rods and identify to insure installation in original location. Remove cylinder head bolts, cylinder head and gasket.

Installation — Coat gasket with suitable sealer. Install gasket and head on cylinder block. Install bolts and tighten in two steps to specifications. Use tightening sequence shown in illustration.

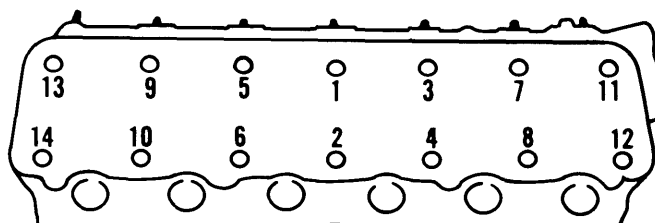

3CR01

CYLINDER HEAD TIGHTENING SEQUENCE

VALVES								
Engine & Valve	Head Diam.	Face Angle	Seat Angle	Seat Width	Stem Diameter	Stem Clearance	Valve Lift	
All	Intake	1.615" - 1.625"	45°	45°	.070-.090"	.372-.373"	.001-.003"	.406"
	Exhaust	1.355" - 1.365"	43°	45°	.040-.060"	.371-.372"	.002-.004"	.414"

VALVE ARRANGEMENT

E-I-E-I-E-I-I-E-I-E-I-E

VALVE GUIDE SERVICING

Wear Check — Remove valve springs and install suitable sleeve (C-3973) over valve stem and install valve. Attach suitable dial indicator to cylinder head and set it at right angle to valve stem being measured. Total sideplay should not exceed .017". If dial reading is excessive or stems are scuffed or scored, ream guides for installation of valves with oversize stems.

Servicing — Ream guides to next oversize valve stem. Oversize valve stems are available in .005", .015" and .030" sizes. **NOTE** — Do not attempt to ream guides from standard diameter to .030" oversize in one step. Use step procedure to obtain the .030".

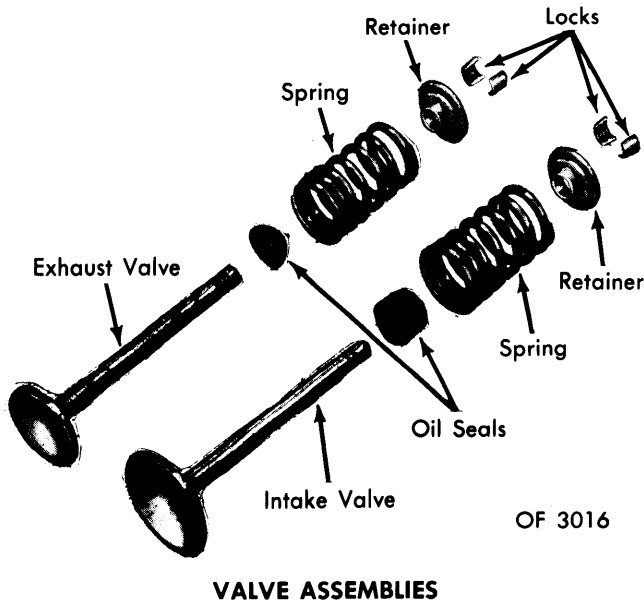

VALVE ASSEMBLIES

VALVE STEM OIL SEALS

Cup type used on all valves. Long seal used on intake valve and short seal used on exhaust valve.

VALVE SPRINGS			
Engine	Free Length	PRESSURE (LBS.)	
		Valve Closed	Valve Open
All	1.92"	49-57 @ 1-11/16"	137-150 @ 1-5/16"

VALVE SPRINGS

Removal — With cylinder head removed, compress valve springs using suitable tool (C-3422A). Remove valve retaining locks, retainers and valve springs.

Installation — Reverse removal procedure and only compress spring enough to install the locks. Check valve spring height.

VALVE SPRING INSTALLED HEIGHT

Valve springs must be square within 1/16". Installed height of spring (measured from spring contact area on head to underside of spring retainer) should not exceed 1 3/4". If height is greater than maximum allowable, install 1/16" spacer(s) to bring height back to normal (1 3/8" to 1 1/2").

ROCKER ARM ASSEMBLY

See illustration for assembly of parts, noting the following: The assembly must be installed with oil hole upward and toward front of engine. Be sure that shaft retainers are seated on rocker shaft and not on extended bushing of rocker arm. Install long retainer at center position and long shaft bolt at rear of engine. Tighten bolts.

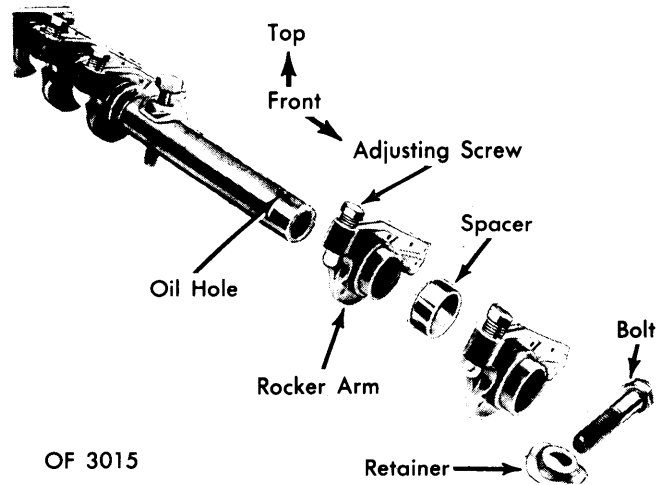

ROCKER ARM SHAFT ASSEMBLY

MECHANICAL VALVE LIFTER ADJUSTMENT

Temporarily set intake to .011" and exhaust to .023" with engine cold. Operate engine until normal operating temperature is reached (approximately 195°F water temperature). Allow engine to idle at 550 RPM at operating temperature for five minutes. Adjust intake to .010" and exhaust to .020" with engine at operating temperature.

PISTONS, PINS, RINGS						
Engine	PISTONS		PINS		RINGS	
	① Clearance	② Piston Fit	Rod Fit	Ring	③ End Gap	Side Clearance
All	.0005-.0015"	.00045-.00075" Clearance	.0007-.0012" Interference	Comp. Oil	.010-.020" .015-.055"	.0015-.003" .0002-.005"

① At top of skirt. ② Tight thumb press at 70° F. ③ Ring 2" from bottom of bore.

OIL PAN

Removal – 1) Drain radiator, disconnect battery, upper and lower hoses and remove oil dipstick. Remove radiator shroud bolts and lay shroud back on top of engine.

2) Raise car on hoist and drain oil pan. Remove center link from steering arm and idler arm ball joints. Support front of engine with jack stand. **CAUTION** – Do not support engine at crankshaft pulley or vibration damper.

3) Remove front engine mount bolts and raise engine 1 1/2" to 2". Remove oil pan bolts. Rotate crankshaft so pan will clear counterweights and remove oil pan.

Installation – Use a new oil pan gasket set and reverse removal procedure.

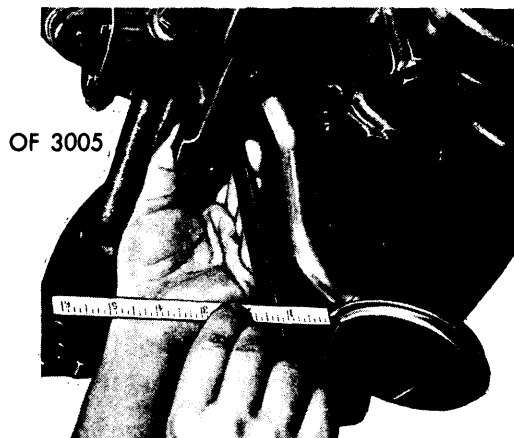

POSITIONING OIL PUMP SCREEN

NOTE – If oil screen and intake pipe are removed for inspection and cleaning, installation requires that pipe be threaded tightly into block so that oil screen is positioned 1 1/8" inside the inside wall of crankcase. Screen must rest against bottom of pan when pan is installed.

PISTON & ROD ASSEMBLY

Removal – With cylinder head and oil pan removed, use a suitable ridge cutter (C-3012) to remove any ridge or deposits on upper end of cylinder bore. **NOTE** – Piston must be at bottom of stroke and covered with cloth to collect cutting. Inspect connecting rods and caps for cylinder identification and mark as necessary. Remove rod cap and push piston and rod assembly out top of cylinder block, taking care not to nick crankshaft journal or cylinder wall. Install rod caps on mating rods.

Installation – 1) Compression ring gaps must be located on piston so they will be on left side of engine and staggered about 60° apart. **NOTE** – Neither gap should line up with oil ring rail gaps. Rotate oil ring expander so gaps are at right side of engine and rotate steel rails so gaps are opposite (positioned above piston pin holes).

2) Lightly coat cylinder bores, pistons and rings with engine oil, slide suitable ring compressor (C-385) over piston and tighten. Install each piston and rod assembly (notch on piston head facing front of engine and oil hole in connecting rod toward right side of engine) in its respective bore and guide connecting rod onto crankshaft journal. Tap piston head with hammer handle to seat connecting rod against crankshaft. Install rod caps, nuts and tighten.

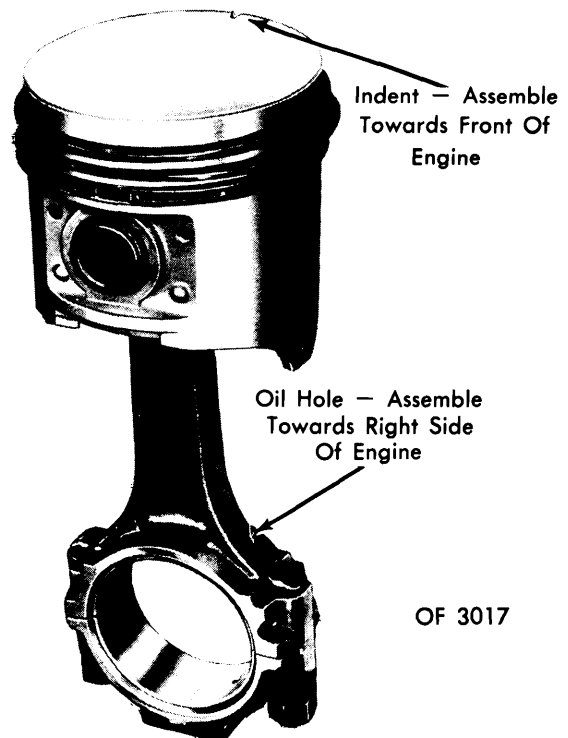

CORRECT ASSEMBLY – ROD TO PISTON

FITTING PISTONS

With pistons and cylinder bores dry and clean, measure for piston-to-cylinder wall clearance (.005-.0015"). Measurements should be taken at room temperature (70°F). Measure piston diameter at top of skirt 90° to piston pin axis. Measure cylinder bore halfway down cylinder and 90° to crankshaft center line.

PISTON PINS

Removal – Use suitable tool (C-3724) to press piston pin from its bore (see illustration).

Installation – Lubricate pin bore and use suitable tool (C-3724) and arbor press to install piston pin while noting following: Position piston head with notch up and connecting rod so oil hole will face right side of engine upon installation. Press pin into position until pin bottoms on pilot of tool.

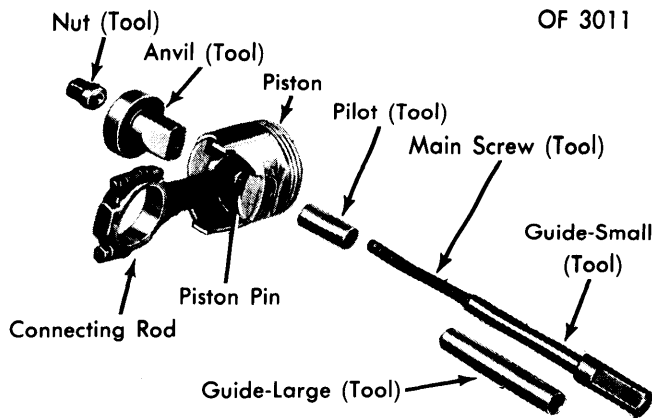

TOOL ARRANGEMENT - PISTON PIN REMOVAL

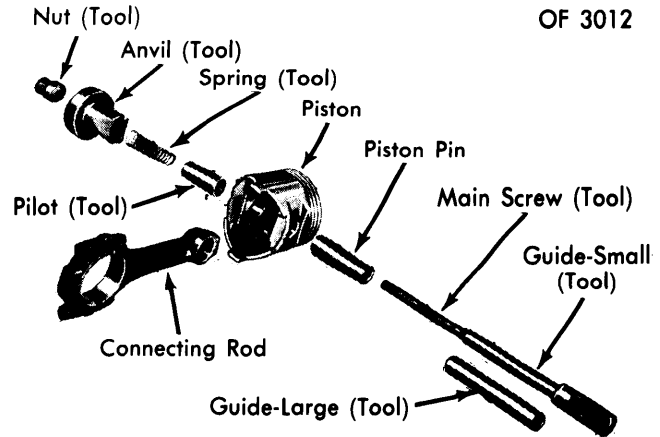

TOOL ARRANGEMENT - INSTALLING PISTON PIN

CRANKSHAFT MAIN & CONNECTING ROD BEARINGS							
Engine	MAIN BEARINGS				CONNECTING ROD BEARINGS		
	Journal Diam.	Clearance	Thrust Bearing	Crankshaft Endplay	Journal Diam.	Clearance	Sideplay
All Engines	2.7495-2.7505"	.0005-.002"	No. 3	.002-.007"	2.1870"	.0005-.002"	.006-.012"

MAIN & CONNECTING ROD BEARINGS

NOTE - Following procedures are with oil pan and oil pump removed.

Connecting Rod Bearings - 1) After ensuring rod caps are marked for cylinder identification, remove rod caps. Smooth edges of a 1/2" by 3/4" piece of brass shim stock .001" thick. Oil and place between bearing and connecting rod journal. Install bearing cap and tighten. Rotate crankshaft 1/4 turn in each direction (Shim Stock Method for checking clearances). If a slight drag is felt, clearance is within limits. If no drag is felt, clearance is excessive. If crankshaft cannot be rotated, clearance is not enough.

2) New bearings are available in standard, .001", .002", .003", .010" and .012" undersize. Always install bearings in pairs. Do not use a new bearing with an old bearing. Install connecting rod bearings so formed tang fits into machined groove in connecting rod. Install rod caps and tighten nuts.

Main Bearings - 1) Use Shim Stock Method and check main bearing clearances, one at a time while all other main bearing caps are tight. New bearings are available in standard, .001", .002", .003", .010" and .012" undersize. A new .001" bearing half may be used in combination with a new standard bearing half or a .002" with a .001". **NOTE** - Always use smaller diameter bearing half as upper.

2) If bearing clearances are not within limits, remove bearing cap, insert suitable tool (C-3509) in oil hole journal and rotate crankshaft clockwise to remove upper bearing half. To install new upper bearing, slightly chamfer sharp edges from plain side and start bearing in place. Insert tool and slowly rotate crankshaft counterclockwise, sliding bearing in place. Install

main bearing cap with new bearing installed and tighten. **NOTE** - Upper main bearings are grooved and lower main bearings are plain. Upper and lower are not interchangeable.

3) Check crankshaft end play and if not within specifications, change number three main bearing. This bearing carries thrust load.

REAR MAIN BEARING OIL SEAL

New split type rubber seals may be replaced without removing the crankshaft. New type seals must be installed as a pair and cannot be used or combined with old type rope seals.

Removal - Remove upper rope seal by turning suitable tool (C-4148) into end of seal and pulling seal out with tool, being careful not to mar crankshaft. Remove lower seal by carefully prying from the side with small screwdriver.

Installation - Oil upper seal lip lightly with engine oil. Hold seal (with paint stripe to rear) tightly against crankshaft with a thumb and rotate crankshaft while sliding seal into groove. **CAUTION** - Sharp edge of groove in block may shave or nick the back of the seal. Care must be exercised not to damage the sealing lip. Install lower half of seal into lower seal retainer with paint stripe to the rear. Install main bearing cap and tighten. Install lower seal retainer and tighten. **NOTE** - Do not use sealer or cement on seal ends or lip.

ENGINE FRONT COVER

Removal - Drain cooling system and remove radiator and fan. Use suitable puller (C-3732A) and remove vibration damper. Loosen oil pan bolts to provide clearance between pan and lower flange of cover. Remove cover bolts and cover.

Installation — Check that mating surfaces of chain case cover and cylinder block are clean and free from burrs. Install cover with new gasket and tighten bolts. Tighten oil pan bolts with gaskets in place. Install vibration damper, radiator and fan. Fill cooling system.

FRONT COVER OIL SEAL

Removal — With front cover removed, use drift and hammer to lightly tap at several positions around seal case. Using vise grips, twist and pull at several positions on seal to remove.

Installation — Use suitable tool (C-3506) to install seal in front cover. Seal is properly installed when seal case is tight against face of cover. A .0015" feeler gauge should not be able to enter between neoprene face and cover.

CAMSHAFT			
Engine	Journal Diam.	Clearance ①	Lobe Lift
All	② No. 1 - 1.998" No. 2 - 1.982" No. 3 - 1.967" No. 4 - 1.951"	.001 - .003"	-----

① Wear limit .005"

② .001" larger diameter permissible

TIMING CHAIN

Checking For Stretch — Place scale next to timing chain to measure any movement of the chain. Place torque wrench with socket over camshaft sprocket lock bolt and apply torque in direction of crankshaft rotation to take up slack. Torque should be 30 ft. lbs. with heads installed or 15 ft. lbs. with heads removed. Apply torque in reverse direction and measure amount of chain movement. If movement exceeds $\frac{1}{8}$ ", replace chain.

Removal & Installation — Remove camshaft sprocket attaching bolt and remove timing chain with camshaft sprocket. Turn crankshaft to line up centerline of camshaft and crankshaft with the timing mark on crankshaft sprocket. Install camshaft sprocket and timing chain. Line up timing marks on the sprockets with centerline of crankshaft and camshaft. Tighten camshaft sprocket bolt.

CAMSHAFT

Removal — Remove tappets using suitable tool (C-4129). Remove timing chain sprockets, distributor, oil pump and fuel pump. Install a long bolt in front end of camshaft to facilitate careful removal. Remove camshaft, being careful not to damage cam bearings with the cam lobes.

Crankcase Capacity — 4 quarts. Add 1 quart with filter change.

Oil Filter — Replace every second oil change. Follow installation directions printed on case of new filter.

Normal Oil Pressure — 30-70 psi at 2000 RPM.

Pressure Regulator Valve — In oil pump body. Not adjustable.

ENGINE OILING SYSTEM

Refer to illustration and note the following:

Installation — Lubricate camshaft lobes and bearing journals. Carefully install camshaft in cylinder block. Install all components removed prior to camshaft removal.

CAMSHAFT BEARINGS

Removal — With camshaft removed, drive out rear cam bearing welch plug. Install proper size adaptors and horseshoe washers (C-3132A) at the back of each bearing and drive out all bearings.

Installation — Install new bearings using suitable tool by sliding new bearing over the proper adaptor. Position bearing on tool. Install horseshoe lock and drive the bearing into place. **NOTE** — Camshaft bearing oil hole or holes must be in exact alignment with drilled oil passages from main bearings. Install number one camshaft bearing $\frac{3}{32}$ " inward from front face of cylinder block. Apply sealer to new welch plug and install at rear of camshaft. Be sure this plug does not leak.

VALVE TIMING

1) Turn crankshaft until No. 6 exhaust valve is closing and No. 6 intake is opening.

2) Turn No. 1 intake valve adjusting screw in one turn to remove lash. Install dial indicator so plunger contacts valve spring retainer at a 90° angle. Zero indicator.

3) Turn crankshaft clockwise until intake valve has lifted .029". Timing indicator on front pulley should read between 12° BTDC and TDC.

4) If front pulley marks are not within limits, inspect sprocket index marks, timing chain for wear or check accuracy of TDC mark on front pulley.

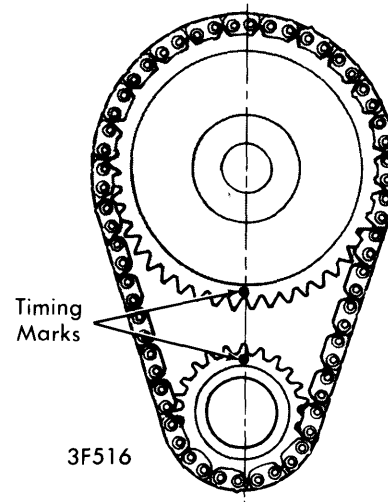

TIMING CHAIN SPROCKET ALIGNMENT

ENGINE OILING

Rocker Arms & Valves — Transverse channel in rear camshaft journal feeds oil from rear camshaft bearing up through channel in block and cylinder head to rear rocker arm shaft bracket (oil flows around rear bracket bolt into rocker shaft). Trough on upper surface of rocker arm lubricates pushrod seats and valve stems.

Crankshaft Bearings — All main bearings are lubricated as shown in illustration. Connecting rod bearings are lubricated by holes drilled in the crankshaft between the main and pin-journals.

ENGINE OILING (Cont.)

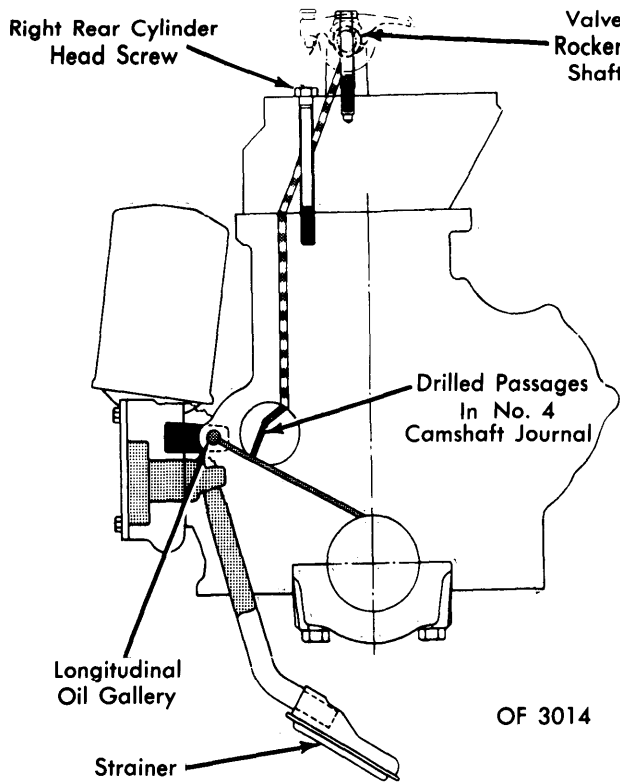

ENGINE OILING SYSTEM

OIL PUMP

Disassembly - Remove pump cover and seal ring. Press off drive gear while supporting gear to eliminate load on aluminum body of pump. Remove outer rotor and inner rotor with shaft. Remove oil pressure relief valve plug, spring and valve.

Inspection - Clean and inspect all parts for damage. Measure all clearances indicated in Oil Pump Specifications table and replace as follows:

- 1) Replace entire pump assembly if pump cover wear, clearance over rotors or outer rotor-to-pump body clearance are not within specifications.
- 2) Replace both rotor assemblies if tip clearance between rotors, rotor thickness or rotor diameter are not within specifications.
- 3) Oil pressure relief valve must be free from scoring and operate freely in bore of pump body. Spring should have a free length of 2 1/4" and test between 22.3 and 23.3 lbs. when compressed to 1 1/32". Replace spring which does not meet specifications.

Assembly & Installation - Assemble pump in reverse order of disassembly using new parts as necessary. Prime oil pump before installation by filling rotor cavity with engine oil. Install pump on engine.

Oil Pump Specifications

Pump Cover Wear.....	.0015" Max.
Inner & Outer Rotor Thickness.....	.649" Min.
Outer Rotor Diameter.....	2.469" Min.
Clearance Over Rotors.....	.004" Max.
Outer Rotor-to-Pump Body Clearance.....	.014" Max.
Tip Clearance Between Rotors.....	.010" Max.

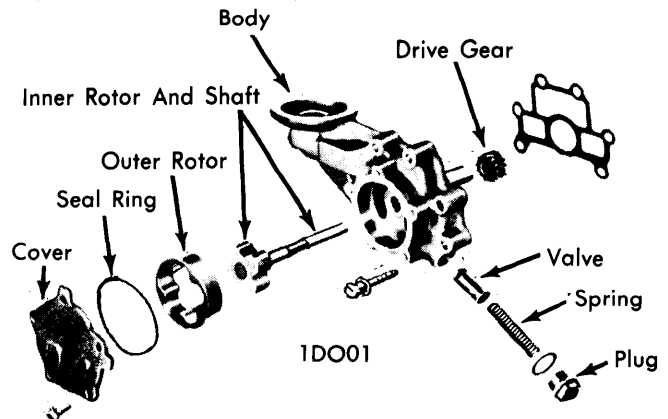

OIL PUMP ASSEMBLY

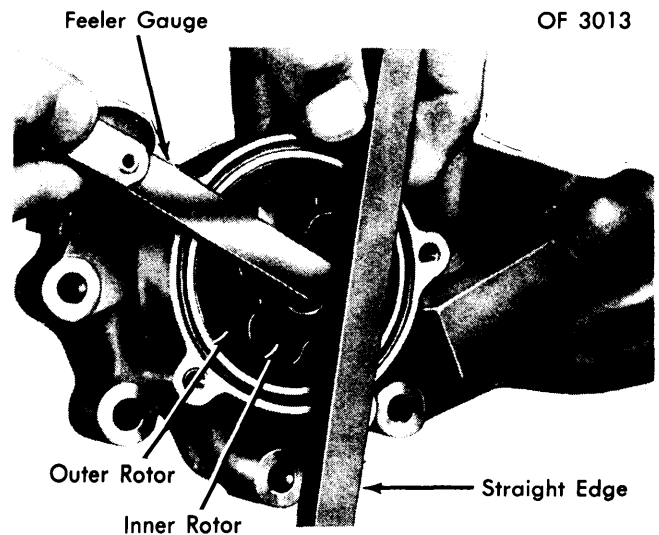

ROTOR CLEARANCE MEASUREMENT

TIGHTENING SPECIFICATIONS

Application	Ft. Lbs.
Cylinder Head.....	70
Manifold-to-Cylinder Head.....	120 INCH Lbs.
Intake-to-Exhaust Manifold.....	240 INCH Lbs.
Oil Pan.....	200 INCH Lbs.
Main Bearing Cap.....	85
Rear Main Bearing Seal Retainer.....	30
Connecting Rod Cap.....	45
Camshaft Sprocket.....	35
Rocker Shaft Support Bracket.....	25
Rocker Arm Cover.....	40 INCH Lbs.
Oil Pump Cover.....	95 INCH Lbs.
Engine Front Cover.....	200 INCH Lbs.
Oil Pump Attaching Bolt.....	200 INCH Lbs.
Water Pump.....	30
Oil Filter Stud.....	10
Front Mount-to-Frame.....	75
Front Mount-to-Engine.....	50