

CHRYSLER CORP. CONCEALED SYSTEM

All Models

(Except Cordoba, Diplomat, Horizon, Mirada & Omni)

DESCRIPTION & OPERATION

Windshield wipers are concealed below hood line when parked. A two speed system is standard, with an intermittent delay system optional. Both systems use the same motor, which reverses at the bottom of its travel to move the blades to the concealed parking position. The intermittent system uses a delay control and variable resistor to vary the sweep interval from 2 to 30 seconds. The intermittent system also has a delay switch on the motor which is not used on the standard system.

TESTING

MOTOR AND LINKAGE

1) Place wiper switch in "LOW" position. If motor can be heard running, check output shaft. If shaft is not turning, replace gearbox. If shaft is turning, check wiper linkage.

2) Connect a voltmeter to terminal "L" at motor with switch in "LOW". If voltage present and motor not running, connect jumper from "P2" to ground. If motor runs, switch or wiring is faulty. If not, check motor brushes and armature.

3) If voltage is present intermittently, check for short circuits in motor, wiring, and switch. Disconnect wiring at motor and remove wiper arms. Connect an ammeter between battery and terminal "L", and a jumper between "P2" and ground. If motor runs and current draw is less than 6 amps, problem is in switch and wiring.

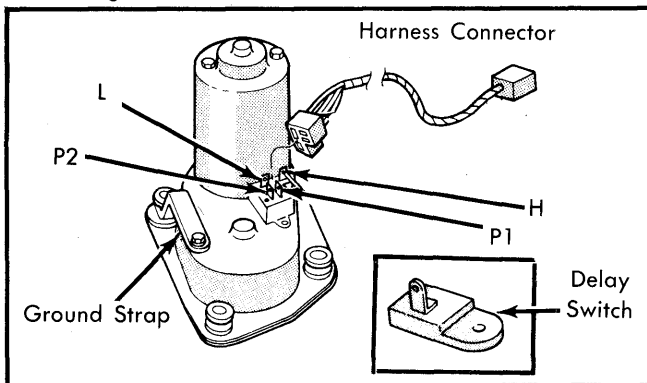

Fig. 1 Chrysler 2-Speed Concealed Motor Terminal Identification

4) If motor does not run or current draw is more than 6 amps, disconnect motor from linkage. If motor now runs and current draw is less than 3 amps, fix linkage. If motor does not run or draws more than 3 amps, repair or replace gearbox and motor.

WIRING AND SWITCH

1) Leave wiring harness connected for the following tests. Connect a test lamp between terminal "L" and ground with switch in "LOW", then connect lamp between "H" and ground with switch in "HIGH". Test lamp should light and motor operate in both positions. If motor does not operate, but lamp lights, check brushes. If lamp does not light, check wiring and switch.

2) To check brushes, connect a jumper from battery to terminal "L", and from "P2" to ground. Motor should run at low speed. Leave battery jumper connected and move ground jumper from "P2" to "H". Motor should run at high speed. If motor

runs, problem is in switch and wiring. If motor does not run, brushes are the problem.

3) If motor does not stop, disconnect wiring and connect a jumper from "P1" to battery, then a second jumper from "L" to ground. Motor should stop and park. If so, control switch is faulty. If not, replace gearbox assembly.

4) If motor will not park properly, disconnect wiring and clean terminals. If problem still exists, turn switch "OFF" and connect voltmeter between "P1" and "L". If voltage is present, check between "P2" and "L". If no voltage is present, between "P2" and "L", replace gearbox. If no voltage is present at all, check switch and wiring.

5) Disconnect wiring at switch. Check switch terminal continuity using the following chart.

Switch	Continuity Position
Off	B to P1 A to Ground
Low	B to A P2 to Ground
High	B to A H to Ground ⓪ P2 to Ground

⓪ — With ohmmeter positive to Ground and negative to P2. With leads reversed, high resistance should be present. If resistance is the same in both directions, replace switch.

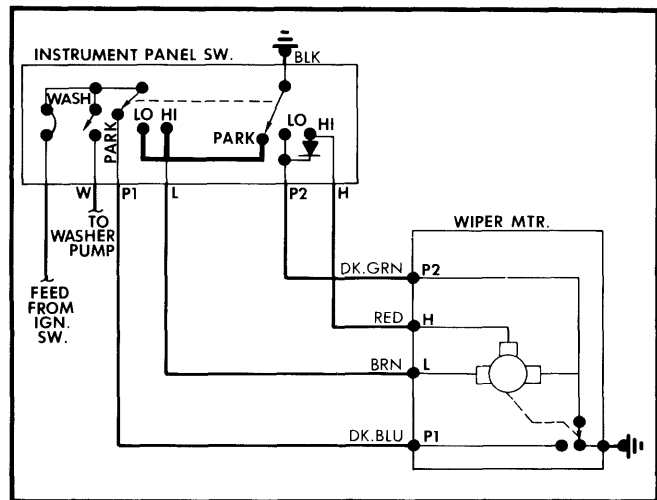

Fig. 2 Chrysler 2-Speed Concealed Wipers Wiring Diagram

INTERMITTENT SYSTEM

1) If wipers do not delay, place switch in "LOW" and disconnect connector from delay control unit. Connect test lamp between cavities 1 and 3 of connector. The lamp should flash once each wipe cycle. If lamp flashes periodically, replace delay control. If no flash, check between motor terminals "P1" and "P2". If lamp flashes, check wiring.

2) If wipers do not operate with switch in intermittent position, place control at maximum delay and disconnect wiring at

Wiper/Washer Systems

CHRYSLER CORP. CONCEALED SYSTEM (Cont.)

delay unit. Connect voltmeter between cavities 4 and 6. If no voltage, check switch and wiring. If 10 to 15 volts, place switch in "LOW" position and check between cavities 3 and 4. If voltage is present, replace delay control unit. If not, check switch and wiring.

3) If wipers only operate once when switch is in intermittent position, place switch in maximum delay position and disconnect wiring at delay unit. Connect voltmeter between cavities 4 and 8. If no voltage, check switch and wiring. If voltage is present, replace control unit.

4) If delay does not vary with control setting, or exceeds 30 seconds, replace switch. If wipers do not operate continuously when in delay mode with washers operating, disconnect wiring at delay control. Connect voltmeter between cavities 4 and 7 and depress "WASH" button. If voltage is 0, check wiring; if voltage is 10-15 volts, replace control unit.

5) Disconnect wiring harness at wiper switch. Test terminals of switch for continuity, using the following chart.

2-Speed Intermittent Switch Continuity	
Switch Position	Continuity
Off	B to P1 A to P2
Delay	B to P1 B to L1 Ⓞ R to L1 L2 to Ground
Low	B to P1 B to A
High	B to P1 B to H

Ⓞ — Resistance at maximum delay: 270K to 330K ohms. Resistance at minimum delay: Zero with ohmmeter at high ohm scale.

REMOVAL & INSTALLATION

WIPER MOTOR

Removal (All Exc. Aries & Reliant) — Disconnect battery ground cable and remove cowl screen. Hold drive crank with wrench while removing crank nut. Remove drive crank and wiring connector. Remove mounting bolts and remove motor.

Removal (Aries & Reliant) — Remove wiper arms and blades. Disconnect hoses from "T" connector. Remove pivot screws, wiper motor cover and disconnect wiring. Remove cowl screen and 3 motor mounting nuts. Push pivots down, pull motor out until it clears mounting studs, then push motor toward driver side of vehicle. Pull right pivot links out, move motor to passenger side and remove left links, pivot and motor.

Installation (All Models) — To install, reverse removal procedures.

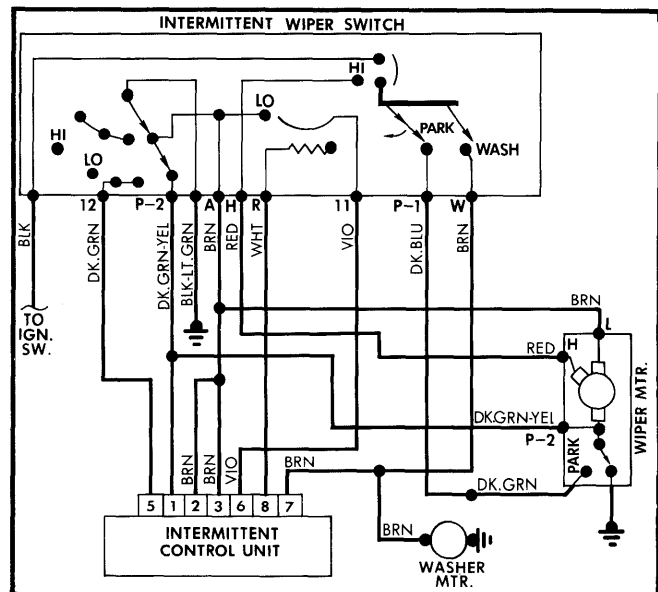

Fig. 3 Chrysler Corp. 2-Speed Concealed Intermittent Wiper Wiring Diagram (Aries, Reliant, LeBaron & 400)

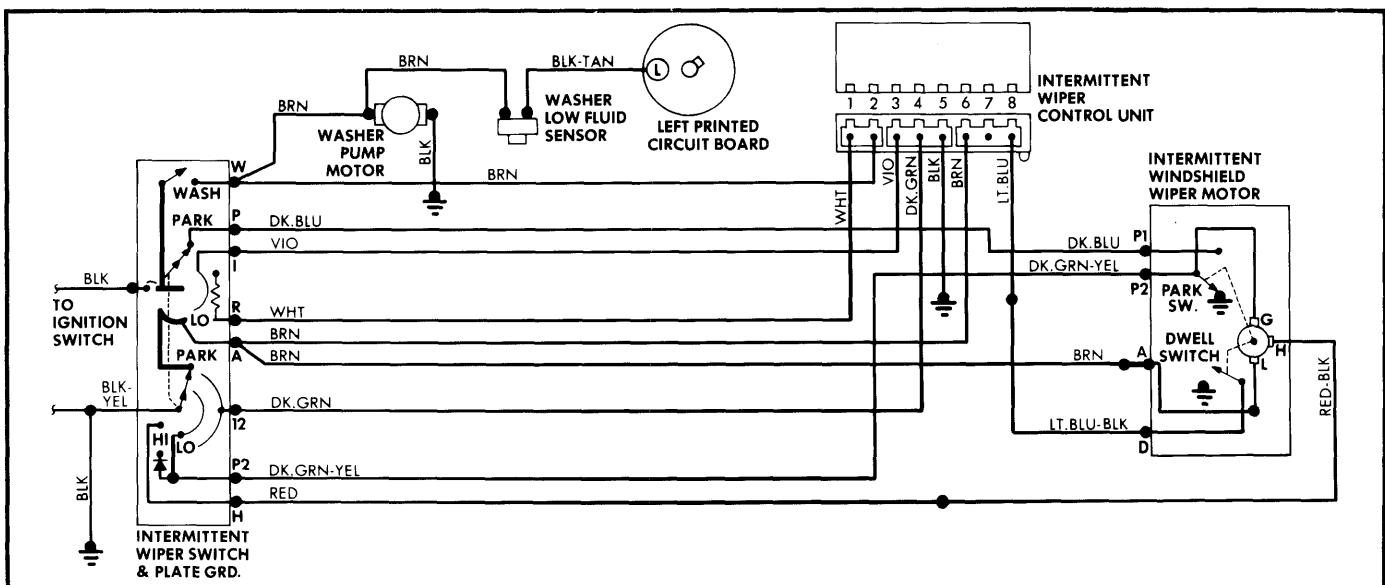

Fig. 4 Chrysler Corp. 2-Speed Concealed Intermittent Wiper Wiring Diagram (All Models Except Aries, Reliant, LeBaron & 400)