

## OLDSMOBILE

### All Models

#### DESCRIPTION & OPERATION

**Fuel Gauge** — Circuit consists of an electrical indicator in instrument panel and a float controlled rheostat in fuel tank. The raising and lowering of fuel in tank varies the circuit resistance through the rheostat, changing the indicator reading.

**Temperature Indicator** — The temperature indicator is actuated by a sending unit which grounds the indicator circuit as engine coolant reaches approximately 260°F. It is also lit when the ignition is "ON" and the engine not running.

**Oil Pressure Indicator** — If engine oil pressure is not satisfactory, sending unit on engine will close completing the indicator lamp ground circuit. Oil pressure light should come on when ignition is on and engine is not running.

**Alternator Indicator** — Indicator light should be on when engine is not running and ignition is turn to "ON". Light should go off and remain off once engine has been started and accelerated above 900 RPM.

**Water in Fuel Indicator (Diesel)** — Diesel vehicles are equipped with an indicator to warn of water contamination in fuel tank. When water in tank nears fuel pick-up level, warning lamp will light.

**Oil Pressure & Temperature Gauges** — Both gauges are optional on all models. Coolant temperature and oil pressure senders are located on the engine and send current to the gauges through 2 magnetic coils and a sender. The sender controls the gauge pointer operation by monitoring the current flowing through the magnetic coils.

#### TESTING

##### FUEL GAUGE

1) If gauge shows empty at all times, disconnect tank unit wire in trunk (Cutlass and Toronado use a pink wire, all others are tan). If gauge moves to full, check sending unit and ground connection. If gauge does not move, disconnect body connector at fuse block. If still at empty, replace gauge.

2) If gauge shows full at all times, check tank ground wire. Disconnect sender and ground sender wire. If gauge moves, check tank sender connections or replace sender. If gauge still shows full, check continuity from gauge to tank. If sender wire has continuity, check printed circuit. If circuit connections are good, replace gauge.

3) If gauge operates, but is inaccurate, disconnect sending unit wire at tank. Connect a known good unit and ground body to frame. Gauge should move as float is moved. If not, replace gauge. If gauge moves, replace sending unit in tank.

##### TEMPERATURE GAUGE

1) With ignition on, disconnect wire at sending unit. Gauge should read 100° F. Ground sending unit wire. Gauge should read 280° F. If gauge reads both temperatures correctly, replace sending unit.

2) If gauge did not read temperatures correctly, remove gauge from panel and check wiring from gauge to sending unit. Repair if necessary. If wiring okay, connect 12 volts to 12 volt terminal on gauge and ground other terminal.

3) If gauge does not read 100° F, replace gauge. If gauge reads 100° F, connect a jumper wire from sending unit terminal on gauge to ground terminal. If gauge does not read 280° F, replace gauge. If gauge reads 280° F, check circuit board and connectors for open circuit.

##### OIL PRESSURE GAUGE

1) With ignition on, disconnect wire at sending unit. Gauge should read 60 psi. Ground sending unit wire. Gauge should read 0 psi. If gauge read correct psi, replace sending unit. If gauge did not read correct psi, remove gauge and check wiring from gauge connector to sending unit. Repair as necessary.

2) If wiring is okay, connect 12 volts to 12 volt terminal on gauge. Ground other terminal. If gauge does not read 60 psi, replace gauge. If gauge reads 60 psi, connect a jumper wire from sending unit terminal on gauge to ground terminal.

3) If gauge does not read 0 psi, replace gauge. If gauge reads 0 psi, check circuit board and gauge connectors for open circuit.

##### INDICATOR WARNING LIGHTS

**Temperature Indicator** — If indicator light remains on with engine running, check for excessive coolant temperature, a grounded wire between bulb and sending unit, or a defective sending unit or ignition switch. If light fails to come on when cranking engine, check for burned out bulb, open light circuit or defective ignition switch.

**Alternator Indicator** — If light comes on with engine running above idle RPM, check alternator output, check for a shorted alternator negative diode or loose or broken alternator belt. If light remains on when ignition is off, check for shorted alternator positive diode. If light remains off when ignition is on but the engine is not running, check for burned out indicator bulb, an open light circuit or an open in alternator field.

**Oil Pressure Indicator** — If light remains on when engine is running above idle speed, check for low oil pressure, a grounded wire between bulb and sending unit or a defective sending unit. If light fails to come on with ignition on and engine stopped, check for burned out bulb, open light circuit or a defective sending unit.

**Water in Fuel Indicator** — 1) If light is on at all times, disconnect fuel tank connector in trunk. If light is still on, repair short to ground in yellow/black wire. If light goes out, drain water from tank. Connect siphon or pump to smaller (1/4") fuel line above rear axle or near fuel pump. Siphon until all water is removed.

2) If light does not come on with water in tank, disconnect connector at tank and ground yellow/black wire. If light comes on, check connections at sensor in fuel tank. If light does not come on, check bulb and continuity from tank to indicator. If still inoperative, replace sensor in tank.

## OLDSMOBILE (Cont.)

### ADJUSTMENT

#### STOP LIGHT SWITCH

**All Models** — Insert switch into clip until switch body seats. Pull pedal up against stop to adjust switch position.

### REMOVAL & INSTALLATION

#### LEFT TRIM COVER

**Removal (88 & 98)** — Remove steering column trim cover and gauge cluster. Remove headlight switch knob. Remove 2 screws under speedometer. Pull cover out of mounting clips.

**Installation** — To install, reverse removal procedure.

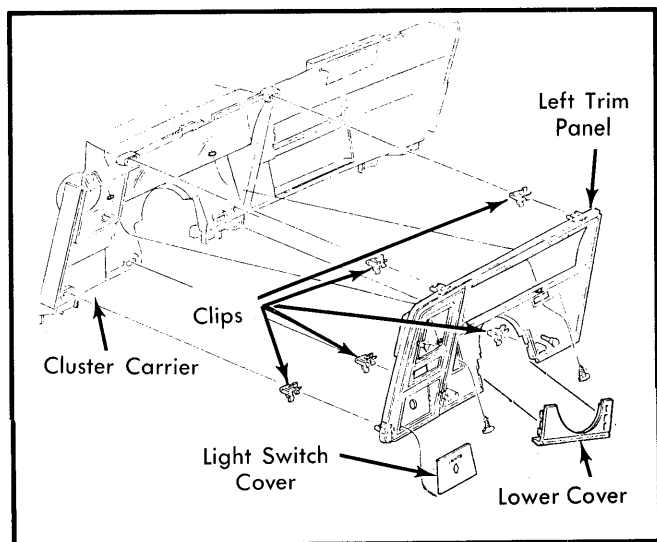

**Fig. 1 Left Trim Panel Removal (88 and 98 Models)**

**Removal (Cutlass Ciera)** — Gently pry left and center trim plates from trim cover. Remove 3 steering column trim collar screws and remove collar. Remove ash tray. Remove 6 trim cover retaining screws and remove cover.

**Installation** — To install, reverse removal procedure.

**Removal (Firenza)** — Remove steering column trim cover retaining screws (6) and lower trim cover. Remove retaining screw from right end of left trim cover. Pull cover out of mounting clips.

**Installation** — To install, reverse removal procedure.

**Removal (Toronado)** — Disconnect battery. Remove headlight switch knob and radio knobs. Remove steering column trim cover, then 4 screws from below left trim cover. Remove sound absorber panel below instrument panel, then pull left trim panel out of spring clips. It may be necessary to lower steering column slightly for clearance.

**Installation** — To install, reverse removal procedure.

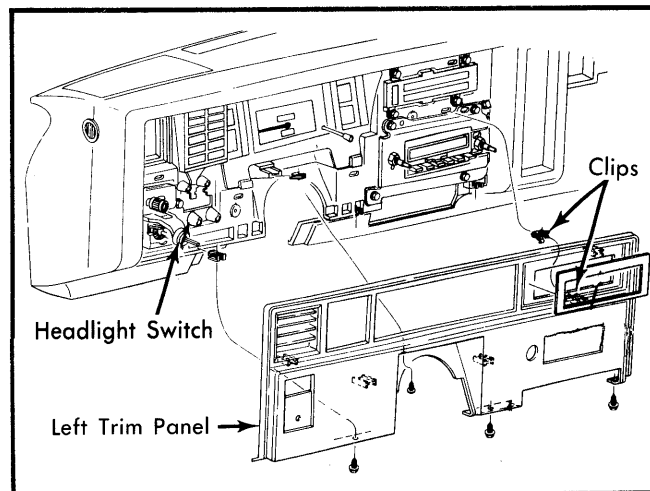

**Fig. 2 Cutlass Instrument Panel Trim Removal**

**Removal (Omega & Cutlass)** — On Omega, pull off headlight switch knob and defogger switch knob. Remove 2 trim cover retaining screws. On both models, pull panel loose from retaining clips.

**Installation** — To install, reverse removal procedure.

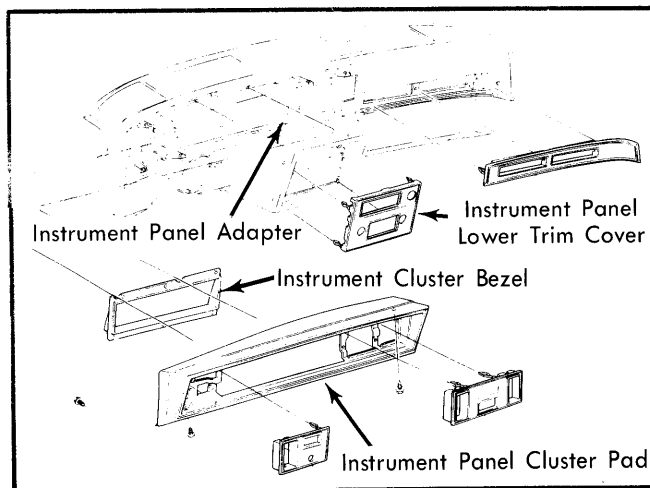

**Fig. 3 Toronado Left Trim Panel Removal**

#### RIGHT TRIM COVER

**Removal (88, 98, Omega)** — Remove cigar lighter and knobs. Remove 2 screws and pull trim panel free from dashboard.

**Installation** — To install, reverse removal procedure.

**Removal (Cutlass)** — Trim panel is mounted with spring clips. Pull out around edges to remove.

**Installation** — To install, reverse removal procedure.

## OLDSMOBILE (Cont.)

**Removal (Cutlass Ciera)** — Pry trim plate from trim cover. Remove 6 trim cover retaining screws and remove cover.

**Installation** — To install, reverse removal procedure.

**Removal (Firenza)** — Disconnect battery. Remove steering column trim cover-to-instrument panel retaining screws (6) and lower trim cover. Remove retaining screw from left end of right trim cover. Remove 2 screws from under center trim cover and 4 screws from front of glove box compartment. Pull cover out of mounting clips and disconnect electrical connectors.

**Installation** — To install, reverse removal procedure.

### SPEEDOMETER, GAUGES & PRINTED CIRCUITS

**Removal (88 & 98)** — 1) Remove steering column trim cover, left trim cover and odometer knob. Remove 4 screws and speedometer lens. Remove 2 screws attaching face plate and adapter plate to cluster carrier. Remove plates. Remove 4 cluster-to-speedometer screws.

2) Disconnect speedometer cable at transmission, or at transducer on cruise control equipped vehicles. Pull speedometer out far enough to release cable clip. Remove screw attaching speed sensor pick-up to speedometer head, if equipped. Remove speedometer, then 2 screws and fuel gauge.

**Installation** — To install, reverse removal procedure.

**Removal (Toronado)** — 1) Remove left trim cover, telltale lens and housing and odometer knob. Remove 2 screws, cluster lens and faceplate. Disconnect shift indicator cable end at pointer. Remove 3 screws attaching speedometer to cluster housing.

2) Remove 2 screws attaching upper gauge assemblies to cluster housing. Pull assemblies rearward to remove. Remove 2 screws attaching lower cluster housing to cluster carrier. Disconnect speedometer cable at transmission, or at transducer on cruise control equipped vehicles.

3) Pull cluster housing out far enough to reach behind and disconnect speedometer cable from clip. Remove speed sensor attaching screw and remove speed sensor, if equipped. Remove cluster housing and speedometer assembly. Remove 2 screws attaching cluster to speedometer and separate assemblies.

4) Remove indicator lamp sockets from cluster housing by twisting them out. Remove gauge terminal clips from cluster housing. Remove printed circuit.

**Installation** — To install, reverse removal procedure.

**Removal (Cutlass)** — 1) On models with cruise control, disconnect speedometer cable at transducer. Remove left and right trim covers. Remove 7 screws attaching cluster pad to instrument panel and remove cluster pad. Remove steering column trim cover and shift indicator clip from column.

2) Remove 4 instrument cluster-to-panel adapter retaining screws. Pull speedometer and gauge cluster back and disconnect speedometer cable. Disconnect speed sensor (if equipped) and remove cluster.

**Installation** — To install, reverse removal procedure.

**Removal (Cutlass Ciera)** — 1) Remove left trim cover. Remove 8 screws attaching cluster trim plate to instrument cluster and remove plate. Disconnect speedometer cable at transmission, or at transducer on cruise control equipped vehicles.

2) Remove steering column trim collar screws (3), steering column trim collar, steering column trim plate retaining screws (4) and trim plate. Disconnect shift indicator clip from steering column shift bowl. Remove 4 instrument cluster attaching screws, pull out cluster and disconnect speedometer cable. Remove cluster assembly.

3) Remove VSS retaining screw from speedometer. Remove 4 cluster lens retaining screws, then remove lens and bezel. Remove screw attaching speedometer head to rear of instrument cluster. Remove retaining screws from front of speedometer and pull speedometer out gently.

**Installation** — To install, reverse removal procedure.

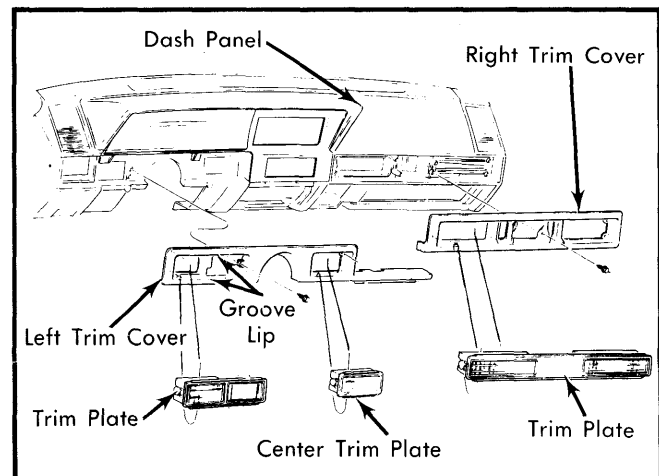

**Fig. 4 Cutlass Ciera Instrument Panel Trim Removal**

**Removal (Firenza)** — 1) Remove right, left and steering column trim covers. Remove 7 screws attaching cluster trim cover to instrument panel and remove trim cover. Remove lens and bezel-to-cluster carrier retaining screws (5).

2) Loosen steering column upper retaining bolts and lower column. Remove cluster housing-to-carrier retaining screws (4), pull cluster out and disconnect speedometer cable. Remove cluster housing.

3) Remove LED/photo cell retaining screw from back of speedometer. Remove speedometer head-to-cluster housing retaining screws (2) from rear of cluster. Remove speedometer.

4) Remove snap-in bulbs from rear of cluster. Disconnect VSS connector. Remove any nuts retaining printed circuit to cluster housing and remove printed circuit.

## OLDSMOBILE (Cont.)

**Installation** – To install, reverse removal procedure.

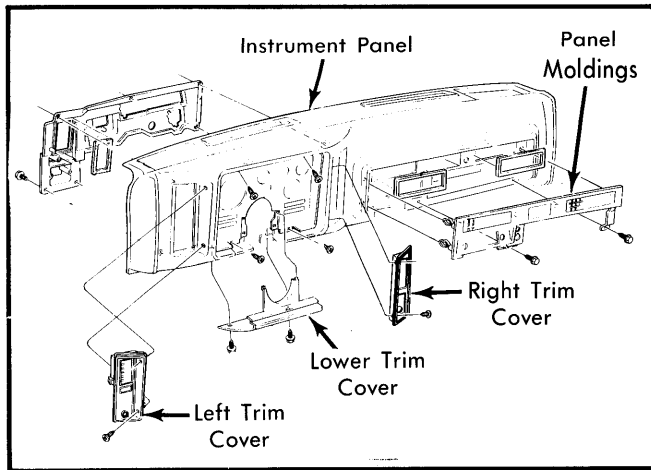

**Fig. 5** Omega Instrument Panel Trim Removal

**Removal (Omega) – 1)** Remove center instrument panel trim cover. Remove 4 screws attaching cluster assembly to instrument panel pad. Disconnect speedometer cable at transmission, or at transducer on cruise control equipped vehicles. Pull cluster assembly out far enough to reach behind and disconnect speedometer cable. Remove cluster assembly.

**2)** Remove 2 screws attaching cluster lens to cluster assembly and remove lens. Remove 2 screws on back side of cluster, and remove speedometer from cluster.

**Installation** – To install, reverse removal procedure.

### HEADLIGHT SWITCH

**Removal (All Models)** – Remove left trim cover. Remove steering column trim cover on 88 and 98. On Cutlass, remove instrument panel pad. On all models, unscrew mounting screw(s), remove wiring connector and pull switch away from panel.

**Installation** – To install, reverse removal procedure.