

FORD MOTOR CO.

Ford Motor Co.

All Except Electronic Instrument Panel

NOTE — Lincoln Continental, Lincoln Town Car, Mark VI, Thunderbird and XR7 models are available with an electronic dashboard assembly. Procedures for servicing vehicles with this assembly are located in the Ford Electronic Instrument Panel article in this Section.

DESCRIPTION & OPERATION

Ammeter Gauge — Gauge is a shunt-type which senses direction and rate of electrical current (amperage) to or from the battery, indicating whether battery is being charged or discharged.

Alternator Indicator — Indicator light will come on when field relay contacts are open. With ignition on and engine not running, battery current flows through the indicator light and 500 ohm resistor, and through the regulator voltage limiter contacts to the field. The light will remain on until the engine is started and the alternator builds up enough voltage to close the field relay contacts, at which time the light will go out.

Fuel Gauge — Gauge pointer is operated by current flow heating a wire wound bi-metal strip in gauge. Current flow is controlled by a variable resistor float type sending unit in the fuel tank. As the amount of fuel decreases, more resistance is placed in the circuit, allowing less current flow and heat at the bi-metal strip, causing pointer to move a shorter distance.

Graphic Display Warning Indicator — Available on Escort and Lynx models only, this system consists of a module which visually displays information on the following items: Tail light failure, headlight failure, brake light failure, low fuel reminder, low washer fluid reminder and a test switch to check if indicators are working. Module is located in shift console beneath instrument panel.

Auxiliary Cluster — Available on EXP and LN7 models only, this system consists of a module which contains ammeter and oil pressure gauges, and door ajar and low washer fluid reminders. Module is located in shift console beneath instrument panel.

Low Fuel Indicator — This warning system consists of an electronic sensor/switch device, located on relay above glove box, and an indicator light in instrument panel. Switch is controlled by the difference in voltage potential between the two terminals of fuel gauge. When tank is less than one-quarter full of fuel, switch is closed by the difference in voltage potential, turning on the indicator light. The indicator should also come on, but for less than one minute, when the ignition is turned to the "ON" position.

Instrument Voltage Regulator — IVR is used in conjunction with all gauges (exc. ammeter). It controls and maintains an average pulsating value of five volts at gauge. A suppression choke is connected in series between printed circuit and IVR to prevent radio interference.

Oil Pressure Gauge — Oil pressure gauge circuit consists of an IVR, oil pressure gauge and a pressure operated sending unit. As oil pressure increases, resistance in sending unit decreases causing an increase in current flow and gauge pointer movement.

Oil Pressure Indicator — The light is connected between the oil pressure sending unit and the coil terminal of the ignition switch. Light should come on when ignition switch is turned to the "ON" position or when oil pressure is not above the prescribed pressure.

Oil Temperature Indicator — Used on turbocharged models, system consists of an oil temperature switch in cylinder head and flasher mounted under instrument panel. When engine oil reaches an excessive temperature, switch turns on "ENGINE" light on instrument panel and flasher, indicating hot engine oil.

Temperature Gauge — System consists of a variable resistance type sending unit and a gauge. As coolant temperature increases, resistance in sending unit decreases allowing an increase of current flow and gauge pointer movement. It is possible, under certain driving conditions, for pointer to read at the top of the normal band and still have coolant temperature within limits.

Temperature Indicator — System consists of a "TEMP" or "ENGINE" light and a normally open-to-ground temperature sensing switch. When coolant temperature reaches approximately 249° F, switch closes circuit to ground, turning on the indicator light. As a test of proper bulb operation, the light will also turn on with the ignition in the "START" position.

NOTE — On models with Automatic Temperature Control type air conditioning systems, the temperature sending unit has two terminals. The terminal marked "R" (gauge equipped) or "C" (indicator light equipped) provides a ground circuit for cold engine override (below 115°F engine temperature) of heater blower motor.

TESTING

CAUTION — When testing gauges and indicators, do not ground or spark either terminal of instrument voltage regulator (IVR). This could burn out IVR and dash wiring harness.

GAUGES

Oil Pressure Gauge Calibration Test — 1) Test equipment consists of 22 and 73 ohm resistors. Perform following test in vehicle with ignition on.

2) Disconnect lead of sending unit and connect 22 ohm resistor between lead and ground. Gauge should read midscale. Connect 73 ohm resistor between lead and ground, gauge should read low.

3) If gauge does not function properly, replace IVR and retest. If gauge now reads correctly, IVR was the problem. If gauge is still incorrect, remove and bench test.

FORD MOTOR CO. (Cont.)

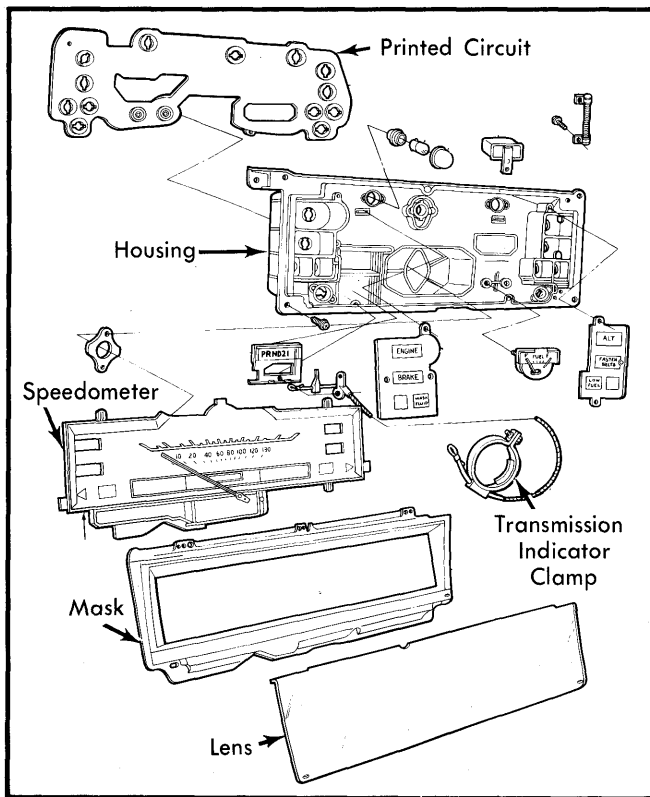

Fig. 1 Ford Instrument Cluster

Ammeter — Turn headlights to "ON" position and ignition to "OFF" position. Meter pointer should move toward the "D" or discharge side of the gauge. If no pointer movement is noted, check the following: Rear of meter housing for loose connections, printed circuit connections, multiple connector at printed circuit. If connections are good replace ammeter.

Oil Pressure Gauge Bench Test — To test gauge for open windings, remove gauge from cluster. Connect gauge to ohmmeter and read resistance. An upward movement of needle from 10 to 14 ohms is normal because current increases the temperature of gauge coil windings. If ohmmeter reads below 10 ohms or above 14 ohms, replace gauge.

Fuel Level Indicator — Disconnect wiring connector from terminals at sender unit. Check terminals for possible corrosion or undercoating, and clean as necessary. Connect the lead of a 12 volt test light, or positive lead of a voltmeter to gauge lead that was disconnected from sender. Connect other test lead to a good ground. With ignition on, a flashing light or fluctuating voltmeter will indicate instrument voltage regulator is operating and that gauge indicator circuit is not interrupted. If light stays on, or voltage reading is steady, replace IVR. If no voltage is indicated by meter or test light, check IVR for proper ground, or open circuit across IVR.

Fuel Level Indicator Calibration Test — 1) When instrument voltage regulator or gauge is suspected of being out of calibration, having a fluctuating movement or a high or low reading, both the gauge and IVR must be tested simultaneously. This test is done on the vehicle.

2) If test is performed with resistors: Disconnect wiring connector at sender unit, connect the resistor between the gauge lead

and a suitable ground. Turn ignition to "ON" position. With the 10 ohm resistor, the gauge should read on or above "FULL". With the 73 ohm resistor, the gauge should read on or below "EMPTY".

3) If test is performed with a good fuel sender: Disconnect wiring connector from sender and connect it to substitute sender, be sure sender is grounded. Turn ignition to "ON" position, move float rod against full stop position (away from fuel filter). The gauge should read on or above "FULL" mark. With float against empty stop, gauge should read on or below "EMPTY" mark.

4) If gauge performs as indicated, replace sender unit. If gauge does not perform as indicated, replace IVR and retest to determine if gauge is causing trouble. If gauge now (with new IVR) reads correctly, problem is solved. If gauge is still out of calibration, gauge is defective and must be replaced.

Fuel Sending Unit — Connect ohmmeter lead to ground terminal or housing, and the other lead to resistance terminal. With float at empty position, ohmmeter should read 60 to 86 ohms. With float at full position, resistance should be 8 to 12 ohms. Resistance change should be smooth as float is moved. If specifications are incorrect or resistance change readings jumped erratically, replace sending unit.

Temperature Gauge — 1) During tests, DO NOT apply 12 volts directly to temperature sender terminal or sender unit will be damaged. Idle engine, with all accessories off, until thermostat opens and coolant temperature stabilizes. Gauge pointer should register in lower half of normal band.

2) To test gauge, proceed as follows: Disconnect gauge lead from terminal at sender unit. Connect lead of a 12 volt test light or positive lead of voltmeter (20 volt scale) to gauge lead that was disconnected from sender unit. Connect other lead to a good ground, turn ignition to "ON" position. A flashing light or fluctuating voltmeter indicates instrument voltage regulator is good and gauge circuit is not interrupted.

3) If a pulsating voltage is shown but gauge is not accurate, perform a calibration test. If light stays on, or voltage reading is steady, replace IVR. If no voltage is indicated by voltmeter or test light, check for an open circuit in IVR, gauge windings, or printed circuit.

Temperature Gauge Calibration Test — 1) When gauge is suspected of being out of calibration, having a fluctuating movement or high or low readings, both gauge and IVR must be tested simultaneously. This test is done on vehicle.

2) Disconnect lead from gauge at sender unit, connect resistor between gauge lead and ground. Turn ignition to on position. With 10 ohm resistor, gauge should read within 1 pointer width on either side on "H" graduation. With 73 ohm resistor, gauge should read within 1 pointer width on either side of "C" graduation.

3) If gauge does not perform as prescribed, replace IVR and retest. If gauge now (with new IVR) reads correctly, problem is solved. If gauge is still out of calibration it is defective and must be replaced.

FORD MOTOR CO. (Cont.)

Temperature Sender (Automatic Temperature Control Models) — Terminal marked "R" (vehicles with temperature gauge) or terminal marked "C" (vehicles with temperature light), should provide a closed circuit at coolant temperatures below 100°F. Circuit should be open at temperatures above 120°F. If sender fails to open or close as specified, replace sender.

INDICATOR WARNING LIGHTS

Alternator Indicator — Disconnect voltage regulator connector in engine compartment and connect a jumper wire between terminal "1" and ground. Turn ignition on. The charge indicator should glow at full brightness. If it does, replace voltage regulator. If not, check bulb and wiring to alternator indicator.

NOTE — *On models with an "ENGINE" warning light, disconnect temperature switch lead before testing oil pressure indicator circuit.*

Oil Pressure Indicator — Turn ignition to "ON" position. If indicator light fails to come on, ground sending unit contact with engine or replace sending unit. If light fails to come on with lead grounded, check bulb and/or circuit for open condition.

NOTE — *Never apply 12 volts directly to sending unit.*

Temperature Indicator — With ignition on, light should come on. If not, check bulb, then check circuit from ignition switch to bulb. If light stays on with ignition on and coolant temperature less than 249°F, disconnect light lead from sender switch. If light goes out, replace switch. If light stays on, check ground circuit from temperature switch to indicator bulb.

"ENGINE" Temperature Indicator — 1) On models with "ENGINE" indicator, oil pressure and temperature switches control light operation. Light should come on with ignition on.

2) If not, check bulb, then disconnect lead from oil pressure switch and connect lead to ground. If light comes on, replace oil pressure switch. If light stays off, check circuit from oil pressure switch to indicator bulb.

3) If light remains on with engine running and coolant temperature less than 249°F, disconnect leads from both switches. Light should go off. Connect oil pressure lead. If light comes on, replace switch. Connect temperature lead, if light stays on, check for short circuit from either switch to indicator light bulb.

Low Fuel Indicator — 1) When ignition is turned on, if fuel level is below $\frac{1}{4}$ tank indicator will stay on, otherwise it should turn off. If operation is faulty, perform the following tests at the low fuel wiring connector, with ignition turned on.

2) Terminal 1 is blank. Connect a test lamp to terminal 2 and ground, then terminal 3 and ground. Lamp will blink on in both cases but be brighter at terminal 3. Connect test lamp between 12 volt source and terminal 4. Test lamp should be on. Connect test lamp between terminal 5 and ground — lamp will be on. Connect jumper between 12 volt source and terminal 6. Fuel indicator should light.

3) If any test fails, check for bad wiring, blown fuse or defective bulb. If all terminals test properly, check gauge and IVR. If both are good, replace low fuel indicator switch/sensor.

REMOVAL & INSTALLATION**HEADLIGHT SWITCH**

Removal (Escort, EXP, LN7 & Lynx) — 1) Disconnect negative battery cable. On models without air conditioning, remove left side air vent control cable and drop cable and bracket down.

2) On all models, remove fuse panel retaining screws and move fuse panel aside. Pull headlight knob out to on position. Depress retainer knob on switch and pull off knob and shaft assembly. Remove bezel, disconnect electrical plug and remove switch.

Installation — To install, reverse removal procedure.

Removal (Lincoln Town Car & Mark VI) — 1) Disconnect battery ground cable. Insert pointed tool into hole at base of headlight knob and pull knob off shaft. Remove bezels from shaft.

2) Remove steering column lower shroud and lower trim panel. Remove 5 screws retaining switch bracket to instrument panel. Pull switch and bracket from panel.

3) Remove wiring connectors and vacuum lines (if equipped). Remove locknut and retaining screw and remove switch from bracket.

Installation — To install, reverse removal procedure.

Removal (All Other Models) — Disconnect battery ground cable. Pull headlight switch to full "ON" position. Reach under panel and press release button, then pull out knob and shaft. Remove bezel and nut, pull switch down and remove wiring connector and vacuum lines (if equipped)

Installation — To install, reverse removal procedure.

All Models with Autolamp Headlight System — *Refer to Automatic Headlights, Ford Motor Co. Autolamp, in this section, for headlight switch and potentiometer service.*

INSTRUMENT CLUSTER

Removal (Ford, Mercury, Lincoln & Mark VI) — 1) Disconnect battery ground cable. Remove speedometer cable from rear of cluster. Remove cluster trim screws and trim cover.

2) Remove lower steering column cover. Loosen screw and remove cable, then remove transmission indicator clamp from steering column.

3) Remove four cluster screws, electrical connectors, and pull cluster from instrument panel.

Installation — 1) Lubricate speedometer drive hole with silicone lubricant. Install cluster and attach electrical plug. Route transmission indicator cable and place indicator bracket on column. Place selector lever in "P" position and align indicator so it shows lever in "P".

FORD MOTOR CO. (Cont.)

2) Connect speedometer cable, then install steering column cover and trim panels. Connect battery ground cable.

Removal (Thunderbird & XR7) — 1) Disconnect battery ground cable and speedometer cable. Remove instrument trim cover and steering column shroud.

2) Remove shift indicator cable clamp screw and remove clamp. Remove cluster retaining screws and disconnect cluster electrical connector. Remove cluster.

Installation — 1) Position cluster on dashboard and connect wiring. Install cable clamp on column and hook cable on pin. Place transmission in "D" and adjust clamp until pointer is directly behind "D". Tighten screw.

2) Replace lens and mask and install screws. Reverse removal procedure to complete installation.

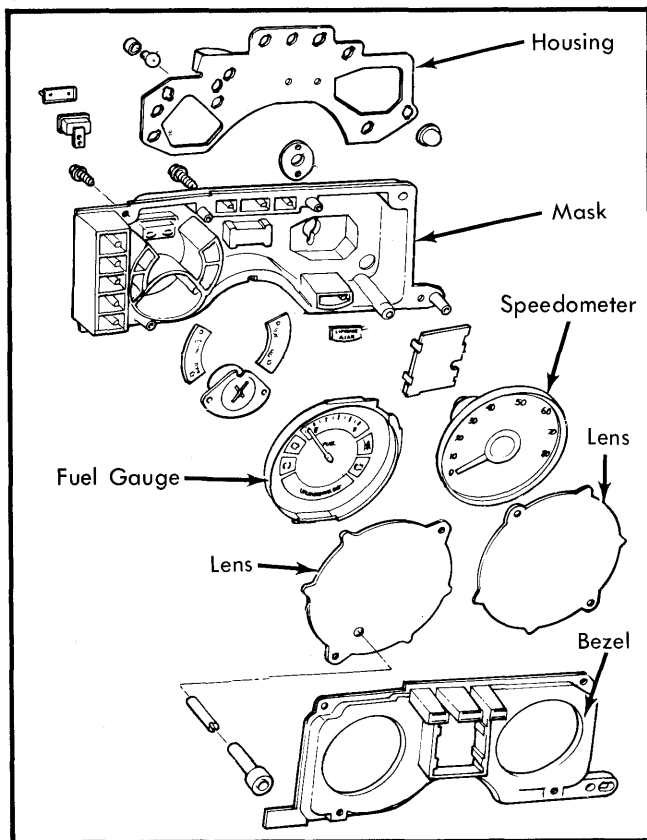

Fig. 2 Fairmont and Zephyr Instrument Cluster

Removal (Escort, EXP, LN7 & Lynx) — 1) Disconnect negative battery cable and remove steering column cover and cluster finish panel. Remove upper and lower screws retaining cluster to instrument panel.

2) Disconnect speedometer cable. Pull cluster away from instrument panel and disconnect electrical connector. Remove cluster.

Installation — To install, reverse removal procedure.

Removal (Cougar, Fairmont, Granada & Zephyr) — Disconnect negative battery cable. Remove steering column cover and cluster trim cover. Remove shift indicator cable clamp from

column. Remove cluster screws, disconnect speedometer cable and wiring, then remove cluster.

Installation — Install speedometer cable and wiring. Position cluster on dashboard and install screws. Install clamp on steering column and hook wire over pin. Place transmission in "D" and move clamp until pointer is directly behind "D" on cluster. Tighten clamp, install trim covers, and connect battery ground cable.

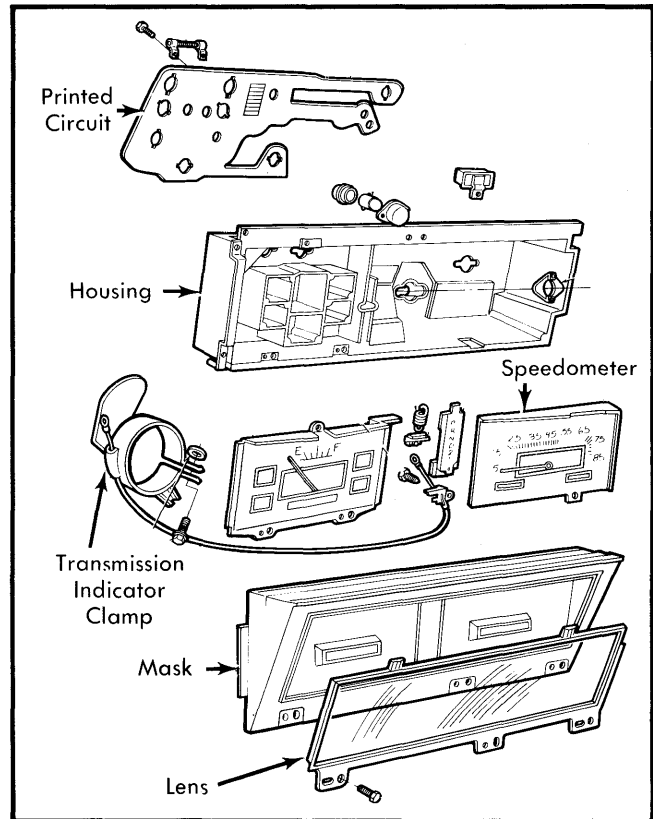

Fig. 3 Thunderbird and XR7 Instrument Cluster

Removal (Mustang & Capri) — 1) Disconnect battery ground cable. Remove 3 upper retaining screws from cluster trim cover and remove cover. Remove 4 screws retaining cluster to instrument panel, pull cluster away from panel and disconnect speedometer cable by pressing on flat surface of cable disconnect.

2) Pull cluster further away from instrument panel, disconnect 2 cluster printed circuit connectors from receptacles in cluster backplate and remove clusters from panel.

Installation — To install, reverse removal procedure.

GAUGES & SPEEDOMETER

Removal (Ford, Mercury, Lincoln & Mark VI) — With instrument cluster removed, disconnect speedometer cable. Remove screws and pull off lens and mask. Remove 2 screws and detach speedometer from cluster. Remove screw from trip meter (if equipped) and unhook reset cable. Remove trip meter.

FORD MOTOR CO. (Cont.)

Installation – To install, reverse removal procedure.

Removal (Escort, EXP, LN7 & Lynx) – With instrument cluster removed, remove screws retaining lens and/or mask assembly. Remove screw retaining fuel gauge and speedometer assembly. Remove fuel gauge first, then remove speedometer assembly from cluster.

Installation – To install, reverse removal procedure.

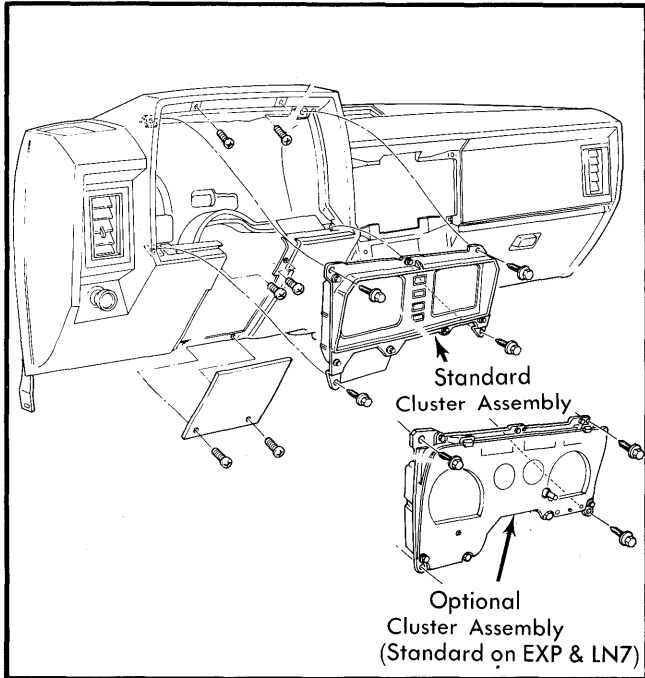

Fig. 4 Escort, EXP, LN7 and Lynx Instrument Cluster

Removal (All Other Models) – With instrument cluster removed, separate cluster mask and/or lens by removing retaining screws and clock knob (if required). Remove speedometer or appropriate gauge retaining screws (or nuts on rear of cluster) and any remaining electrical or cable connections to that particular instrument.

Installation – To install, reverse removal procedure.

STOP LIGHT SWITCH

Removal (All Models) – Disconnect wire harness from switch. Remove hairpin retainer and slide switch, pushrod, nylon washers and bushing away from pedal. Remove switch by sliding it up and down until it is free.

Installation – Position switch so "U" shaped side is nearest pedal and directly over the pin. Slide switch up and directly over the pin. Slide switch up and down and trap push rod and bushing between switch sideplates. Push switch and push rod firmly toward brake pedal arm and attach bushing and retainer to switch. Connect wire connector and check operation of switch.

PRINTED CIRCUITS

Removal (All Models) – With instrument cluster removed, remove IVR. Disconnect all wiring, illumination and indicator bulbs, and remove gauge retaining nuts. Take printed circuit off cluster rear surface.

Installation – To install, reverse removal procedure.

GRAPHIC DISPLAY WARNING INDICATOR

Removal (All Models) – Remove console trim panel by prying at bottom to disengage retainers. Remove 3 retaining screws. Pull module outward, disconnect electrical connectors and remove module.

Installation – To install, reverse removal procedures and ensure locator pegs are in their respective holes before tightening screws.

INSTRUMENT VOLTAGE REGULATOR

Removal (All Models) – With instrument cluster removed, remove IVR-to-cluster retaining screw and snap IVR off printed circuit. Separate IVR from radio noise suppressor (if equipped).

Installation – To install, reverse removal procedure.