

CHRYSLER CORP.

All Models (Exc. Imperial)

CAUTION — Disconnect fusible link in engine compartment before servicing instrument panel.

DESCRIPTION & OPERATION

Fuel, temperature and oil pressure gauges operate on the constant voltage principle through a voltage limiter. On models equipped with Gauge Alert System, the fuel, temperature and ammeter gauges have a small light emitting diode mounted in gauge dial. Light will illuminate when gauge indicates a dangerous condition. The electronic sensor is located on the gauge housing and must be replaced as a unit.

Fuel Gauge — A hinged float arm in the fuel tank moves up and down with fuel level, and contacts a variable resistor in the sending unit. The resistance reading varies voltage in the dash gauge, causing the needle to move and indicate fuel level.

Temperature & Oil Pressure — The operation of temperature and oil pressure indicating systems are identical in operation with the fuel system, with the exception of the method of varying resistance of sending unit.

In temperature, the resistance of the disc in sending unit varies with a direct relation to coolant temperature. When coolant temperatures are high resistance is low, when coolant temperatures are low, resistance is high.

In oil pressure, the sending unit resistance is controlled by a diaphragm. The diaphragm is actuated as oil pressure increases or decreases.

Oil Pressure Indicator Light — The oil pressure switch is mounted on the engine (location depends on engine). When oil pressure is high (normal) switch is held in "Off" or "Open" position, allowing no current to flow to the indicator light. When oil pressure is low, switch is in "On" or "Closed" position allowing current to flow to the indicator light.

Alternator Indicating System — Alternator gauge is an ammeter which senses the direction and rate of flow of electrical current to or from the battery, thereby indicating if battery is being charged or discharged.

Charge Indicator (Aries, LeBaron, Reliant & 400) — The charge indicator light comes on when ignition voltage at instrument cluster drops below 11.2 volts. This system monitors the complete charging system, not just the alternator output. An electronic module plugged into printed circuit senses voltage between cluster feed and ground.

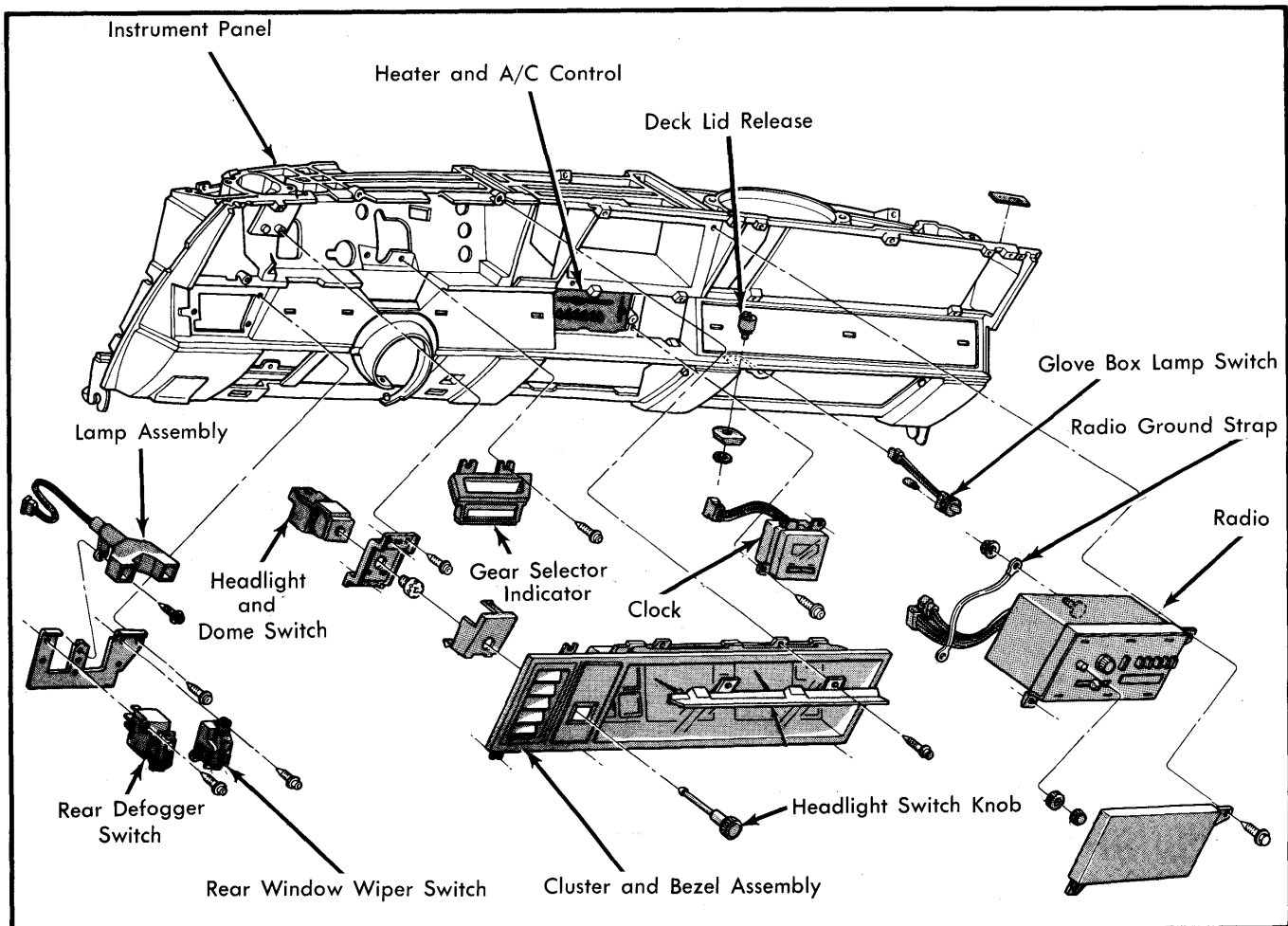

Fig. 1 Aries, LeBaron, Reliant & 400 Instrument Panel

CHRYSLER CORP. (Cont.)

TESTING

VOLTAGE LIMITER

To quickly test voltage limiter in vehicle, connect one lead of a voltmeter or test light to temperature sending unit and other lead to a good ground. Leave sending unit wire attached to sending unit. Turn ignition to "ON". A fluctuating voltmeter or a flashing light indicates voltage limiter is operating.

FUEL GAUGE

1) With sending unit removed from tank, clip float arm to empty stop and turn ignition to "ON" position. After two minutes, gauge should read "EMPTY", plus one pointer width or minus two pointer widths.

2) Move and clip float arm to full stop. Gauge should read "FULL", plus two pointer widths, minus one pointer width.

3) If gauge does not meet specifications, check wiring and connections. If all are good, replace gauge. If gauge works properly with substituted sending unit, replace tank sender.

TEMPERATURE & OIL PRESSURE GAUGES

1) Disconnect lead from sending unit. Connect one lead of a variable resistor to sending unit wire, and the other to ground. A fuel tank sender may be substituted for the resistor.

2) With 80 ohms resistance, pressure or temperature should read low. With 23 ohms, gauge should read in middle of range. With 10 ohms resistance, gauge should read high and warning indicator should light (if equipped).

3) If gauge operates properly in testing but not with sending unit, replace sender. If gauge does not operate properly with resistor, check sender wire for shorts. If wire is good, replace gauge.

AMMETER GAUGE

Turn headlights on (do not start engine). Ammeter needle should move toward the "D" or discharge scale. If no movement of the needle is observed, check terminals for loose wires. If terminals are secure, ammeter is defective. If needle moves toward the "C" or charge side, the connections are reversed.

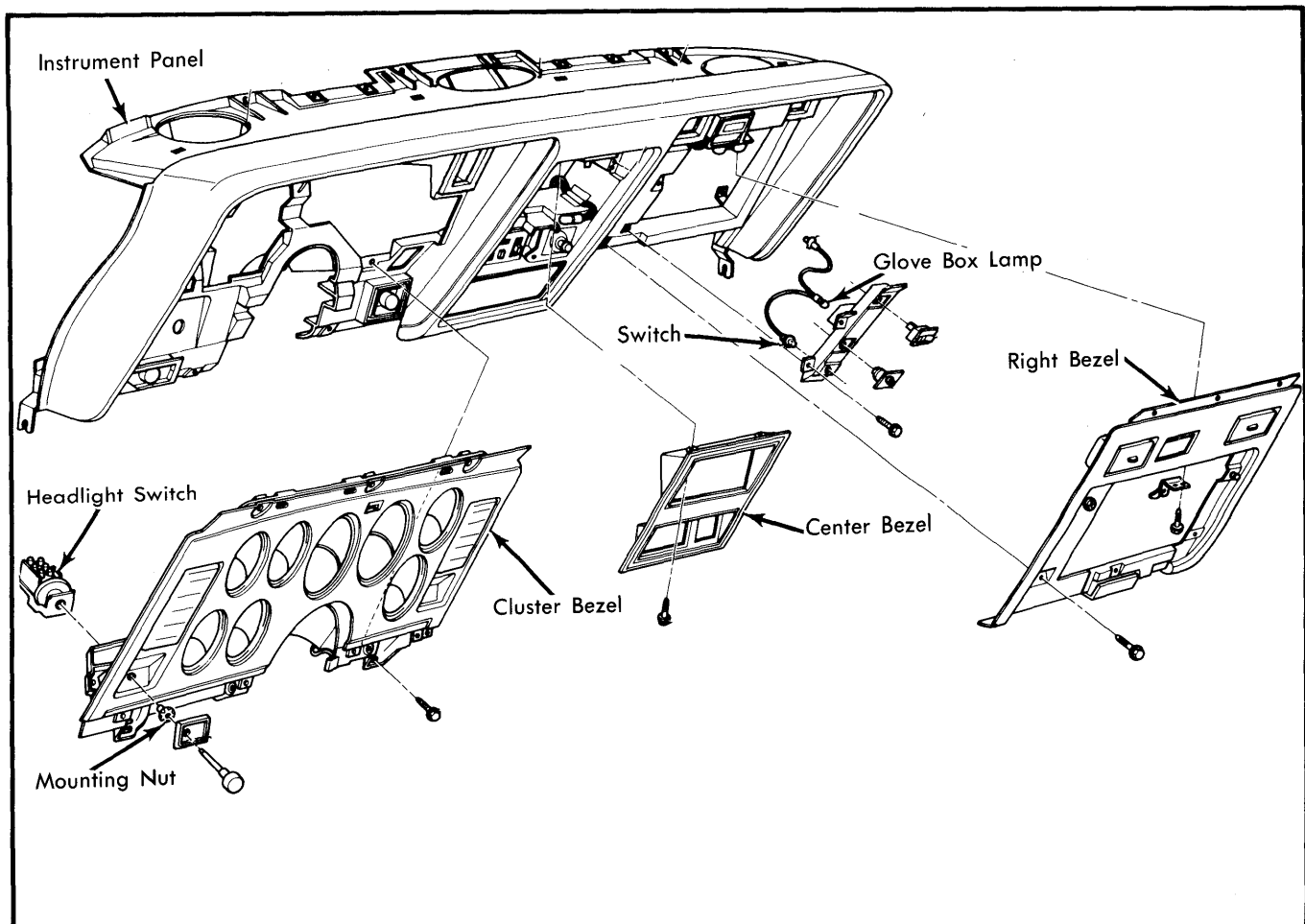

Fig. 2 Cordoba & Mirada Instrument Panel

CHRYSLER CORP. (Cont.)

TEMPERATURE & OIL PRESSURE INDICATOR

Turn ignition "ON", disconnect sender wire and touch to ground. Indicator should light. If not, check bulb and wiring. If indicator stays on and pressure and temperature are not abnormal, check for short in sender wire, or replace sender.

CHARGE INDICATOR (ARIES, LEBARON, RELIANT & 400)

1) Remove lower instrument panel steering column cover and fuse block cover. Connect negative side of a voltmeter to ground and positive side to lower small hole in fuse cavity 11. Turn ignition switch on.

2) Gradually increase electrical load by turning on accessories one at a time. The light should reach full intensity as voltage drops below 11.2 volts.

3) If no voltage, check for blown fuse or loose connections. If light fails to light, check for burned out bulb, defective socket or loose connections at voltage monitor.

ADJUSTMENT

STOP LIGHT SWITCH

All Models (Except Aries, LeBaron, Reliant & 400) - 1) Loosen switch assembly screw. Press brake pedal down and release. Place a .130" spacer gauge against pedal-to-switch surface.

NOTE - Do not pull brake pedal back at any time.

2) Press switch against spacer until plunger is fully depressed. Tighten switch mounting screw, remove spacer, and check switch operation.

Aries, LeBaron, Reliant & 400 - 1) Install switch in retaining bracket and push it forward as far as possible. Brake pedal will move slightly forward.

2) Gently pull back on pedal, bringing striker back toward switch until pedal will go no farther. This will cause switch to ratchet backward to correct position.

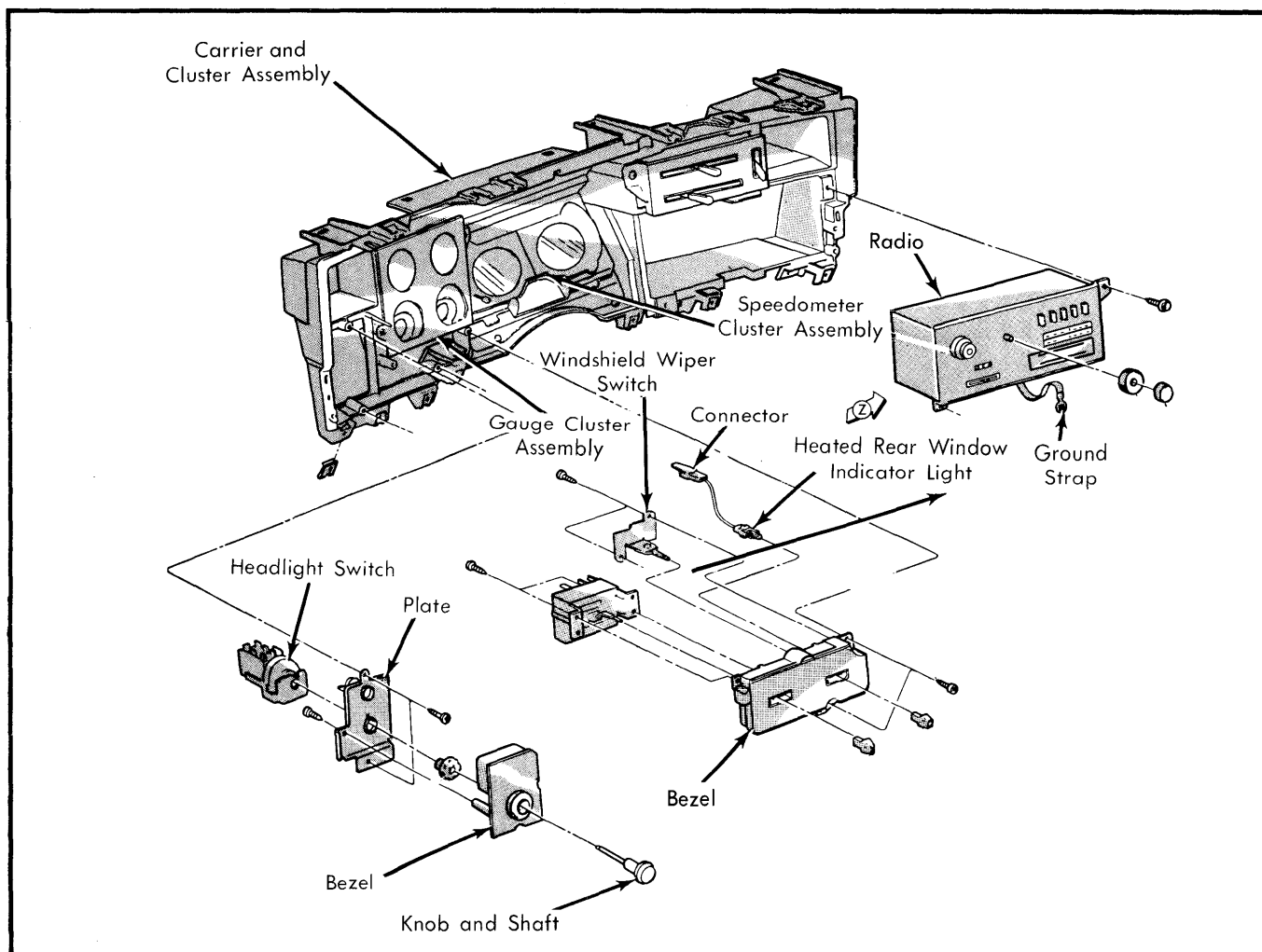

Fig. 3 Diplomat, Gran Fury & New Yorker Instrument Panel

CHRYSLER CORP. (Cont.)

REMOVAL & INSTALLATION

STEERING COLUMN LOWERING & RAISING

NOTE — This procedure is not for removal and installation of steering column and should be used only when necessary.

Removal (Cordoba & Mirada) — Lift cover by either edge to loosen clips. Raise rear edge of cover above trim pad and pull out to remove.

Lowering — 1) Disconnect fusible link. On Cordoba and Mirada models, remove lower left and right bezels, and gearshift pointer cable.

2) On Diplomat, Gran Fury and New Yorker models, remove steering column cover, lower reinforcement and gearshift pointer from steering column.

3) On all models, remove 3 toe plate bolts at firewall, 2 nuts and washers attaching steering column support bracket. Lower steering column to seat.

Raising — Reverse lowering procedure, ensuring that wiring does not get caught. Tighten column nuts to 110 INCH lbs., and toe bolts to 200 INCH lbs.

INSTRUMENT PANEL TOP COVER

Removal (Aries, LeBaron, Reliant & 400) — Remove 3 screws from defroster vent. Remove 4 (Aries and Reliant) or 6 (LeBaron and 400) screws from rear instrument panel top cover. Slide rearward to remove.

Installation — To install, reverse removal procedure.

Removal (Cordoba, Mirada, Newport, New Yorker, St. Regis) — Lift cover by either edge to loosen clips. Raise rear edge of cover above trim pad and pull out to remove.

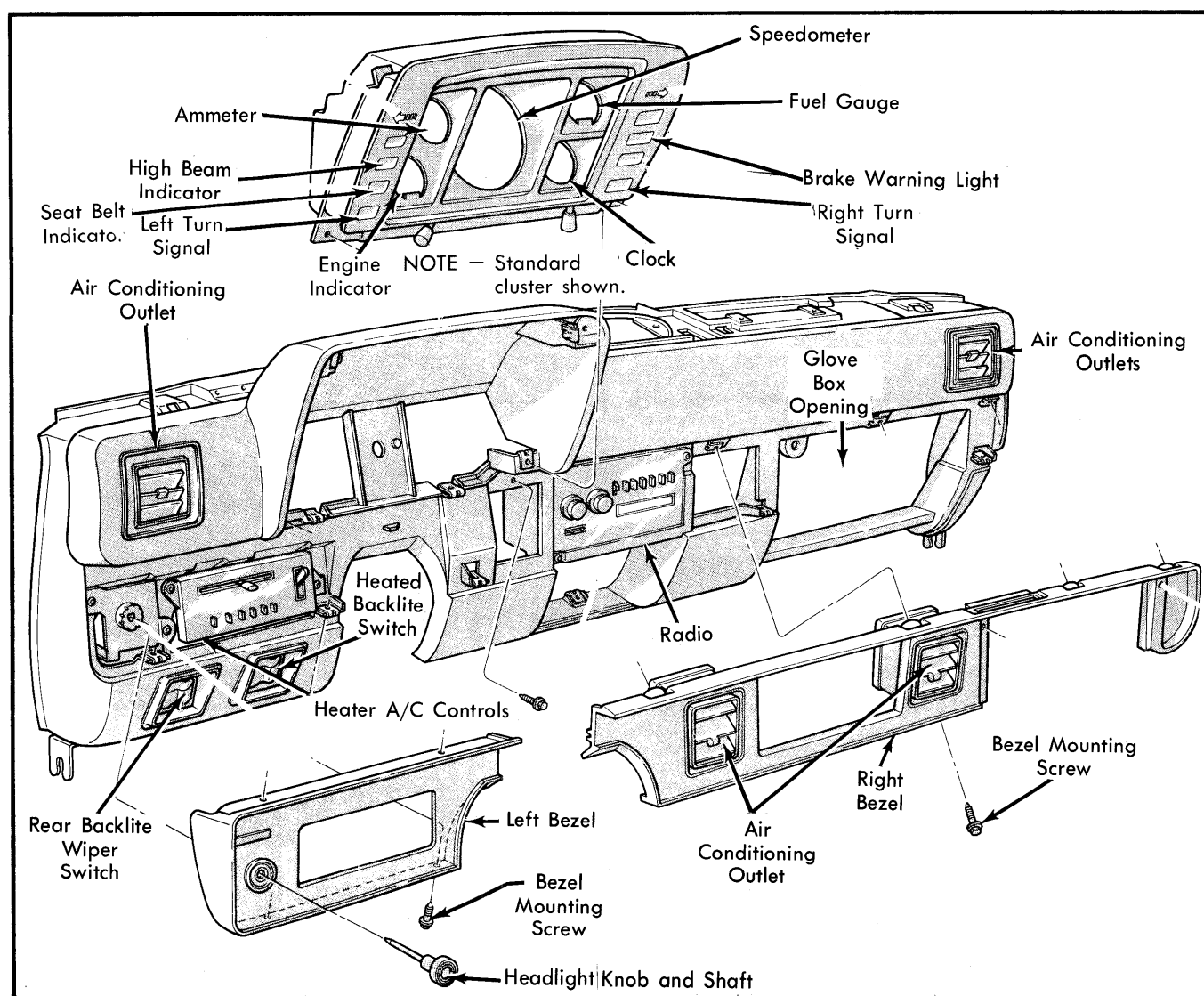

Fig. 4 Horizon & Omni Instrument Panel

CHRYSLER CORP. (Cont.)

Installation — To install, reverse removal procedure.

Removal (Diplomat, Gran Fury & New Yorker) — Remove cluster bezel. Remove 3 screws at right of pad, 1 at each lower side of cluster, 3 screws above cluster, and 4 screws in defroster vents. Disconnect any wiring and remove top cover assembly.

Installation — To install, reverse removal procedure.

SPEEDOMETER, CLUSTER, GAUGES & PRINTED CIRCUIT

Removal (Aries, LeBaron, Reliant & 400) — 1) Place gearshift lever in "1" position. Remove left upper and lower cluster bezel screws. Remove bezel and cluster mask by prying them off remaining clips.

2) Remove 8 screws attaching upper right bezel. Remove 4 (Aries and Reliant) or 6 (LeBaron and 400) screws securing instrument panel top cover.

3) Lift rear edge of top cover and remove 2 screws attaching cluster housing to base panel. Remove 2 screws attaching cluster housing to base panel from lower cluster.

4) Lift back edge of top cover and slide cluster housing rearward. Reach behind cluster and disconnect right printed circuit connector, speedometer cable and left printed circuit connector. Service gauges by removing mounting screws and wiring connectors.

Installation — To install, reverse removal procedure.

Removal (Cordoba and Mirada) — 1) Press headlight switch button and pull out knob and shaft. Place gear shift in "L" position. Remove 7 bezel screws and bezel.

2) Remove 4 plastic pins on each side and remove right and left bezel lenses carefully. Service speedometer and gauges by removing mounting screws and any wiring.

3) To service printed circuits, remove right and left lower trim panels. Remove gearshift cable and lower steering column. Disconnect speedometer cable and right remote mirror cable (if equipped).

4) Remove 5 screws (3 upper and 2 lower) attaching cluster to dash. Roll cluster down, remove wiring and pull from dash. Remove gauges, clips, limiter, bulbs and circuit board.

Installation — To install, reverse removal procedure.

Removal (Diplomat, Gran Fury & New Yorker) — 1) Remove bezel screws. Position gearshift in "1" position and pull bezel away from dash. Remove gearshift pointer by loosening set screw on side of column.

2) Disconnect speedometer cable and remove cluster screws. Disconnect wiring and remove cluster. Remove odometer knob. Remove 4 plastic pins and pull lens and mask away from cluster housing.

3) Remove 2 screws and speedometer. Disconnect odometer switch connector, if so equipped. To remove separate gauge cluster, remove 3 screws, disconnect wiring and remove cluster. To remove circuit boards, pry away from cluster assembly and remove voltage limiter.

Installation — To install, reverse removal procedures.

Removal (Horizon and Omni) — 1) Remove lens bezel assembly by pulling retaining pins (located at lower corners) out with pliers. Pull panel back and down, then remove. Remove 2 screws and speedometer. Disconnect 2 wiring harness connectors.

2) Remove cluster screws at lower corners of cluster, then disengage from spring clips and pull cluster out. Disconnect clock wires and remove cluster from vehicle. Gauges may be serviced by removing mounting screws.

Installation — To install, reverse removal procedure.

HEADLIGHT SWITCHES

Removal (Aries, LeBaron, Reliant & 400) — 1) Remove 3 screws securing headlight switch mounting plate to panel. Pull switch and plate rearward and disconnect wiring connector.

2) Remove knob and stem by depressing button on switch. Snap out excutcheon. Remove nut attaching switch to mounting plate and remove switch.

Installation — To install, reverse removal procedure.

Removal (Cordoba & Mirada) — 1) Remove power antenna and intermittent wiper assembly from under dash (if equipped). Press switch release button and pull out stem and knob.

2) Snap out trim panel with small screwdriver. Remove mounting nut attaching switch to mounting plate. Disconnect wiring and remove switch.

Installation — To install, reverse removal procedure.

Removal (Diplomat, Gran Fury & New Yorker) — 1) Remove cluster bezel and switch mounting screws. Pull module. Depress release button on switch and pull stem and knob from headlight switch.

2) Using a Phillips screwdriver through stem opening, remove switch mounting nut. Disconnect switch wiring and remove switch.

Installation — To install, reverse removal procedure.

INSTRUMENT PANEL SWITCHES

Switches can be removed from front of instrument panel or from cluster bezel after removing bezel from cluster housing.

NOTE — Procedures for windshield wiper switch removal can be found in the appropriate Windshield Wipers/Washers article in this Section.