

## CHRYSLER CORP.

### DESCRIPTION

Electric window lift motors for front, rear and quarter panel windows are permanent magnet type. Motors are grounded through the master switch by a black lead attached to the left cowl panel.

### TESTING

**NOTE** — Check inoperative glass for a binding condition between glass and run channels. Correct binding before making electrical tests.

### SWITCH VOLTAGE

Remove switch from trim panel and carefully disconnect multiple terminal block on wire harness from switch body. Using a suitable test lamp, connect one lead of test lamp to black wire terminal and other test lamp lead to tan wire terminal. If light comes on, power circuit from battery is good. If light does not come on, check 30 amp. power fuse (circuit breaker), or for broken or shorted wire in circuit.

### SWITCH "UP" TEST

1) Using two jumper wires, connect one jumper wire end to tan wire terminal and other end of jumper wire to "UP" terminal (see Fig. 1). Connect other jumper wire to "DOWN" terminal and ground (see Fig. 1).

2) If motor runs, power circuit to motor or switch is good. Reinstall switch to multiple connector and actuate switch. If motor does not run, replace switch body. If motor still does not run with switch replaced, perform Motor Lift Test. Test each window switch using same procedure.

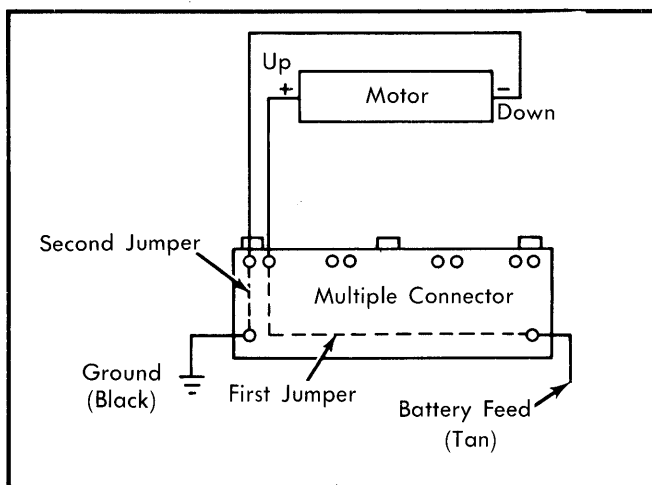

Fig. 1 Switch "UP" Test Circuit

### SWITCH "DOWN" TEST

1) Using two jumper wires, connect one jumper wire end to tan wire terminal and other end of jumper wire to "DOWN" terminal (see Fig. 2). Connect other jumper wire to "UP" terminal and ground (see Fig. 2).

2) If motor runs, power circuit to motor or switch is good. Reinstall switch to multiple connector and actuate switch. If motor does not run with switch replaced, perform Motor Lift Test. Test each window switch using same procedure.

run with switch replaced, perform Motor Lift Test. Test each window switch using same procedure.

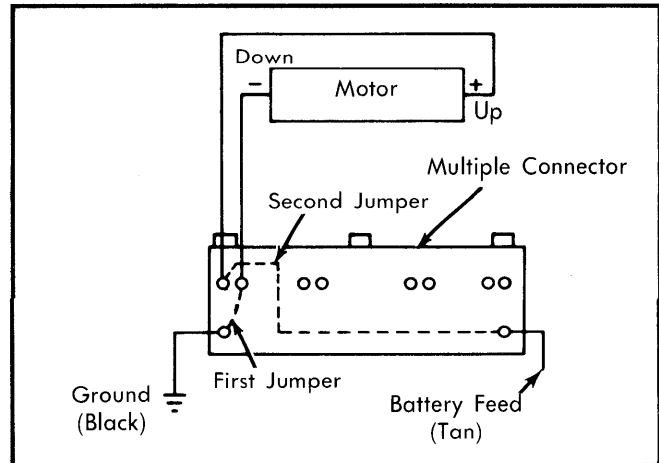

Fig. 2 Switch "DOWN" Test Circuit

### MOTOR LIFT TEST

1) Check motor by connecting a test battery positive lead to either of the motor terminals. Connect the negative lead of test battery to the opposite motor lead. Motor should operate to move window up or down unless window is already at the end of its travel.

2) Reverse the test battery leads. The motor should operate in opposite direction. If not, replace motor.

## REMOVAL & INSTALLATION

### WINDOW REGULATOR & MOTOR

**Removal** — Remove inner door panel and wiring connector for motor. Remove 3 rivets holding regulator to inner door frame. Remove screw holding motor bracket to door frame (if equipped). Disengage drive slider from glass channel and remove regulator and motor.

**Installation** — To install, reverse removal procedure and test motor after installation.

### FRONT & REAR DOOR WINDOW MOTOR

**NOTE** — Following procedure is not recommended if any system parts are loosened or removed from door. If window system parts other than motor are to be removed, use procedure for removing Window Regulator and Motor.

**Removal** — 1) With door trim panel removed, raise window to full up position and support with a block while removing motor. Disconnect wiring and remove screws holding motor to regulator and bracket support.

2) To remove motor, grip motor housing and pull towards outer panel, rocking action may be necessary to disengage motor from regulator.

**CAUTION** — Keep fingers away from sector gear area to avoid pinching by regulator linkage movement.

**Installation** — To install, reverse removal procedure and note the following: Position motor gearbox to engage regulator sector teeth. Center post on gearbox must fit into pilot hole on plate.

# Power Windows

## CHRYSLER CORP. (Cont.)

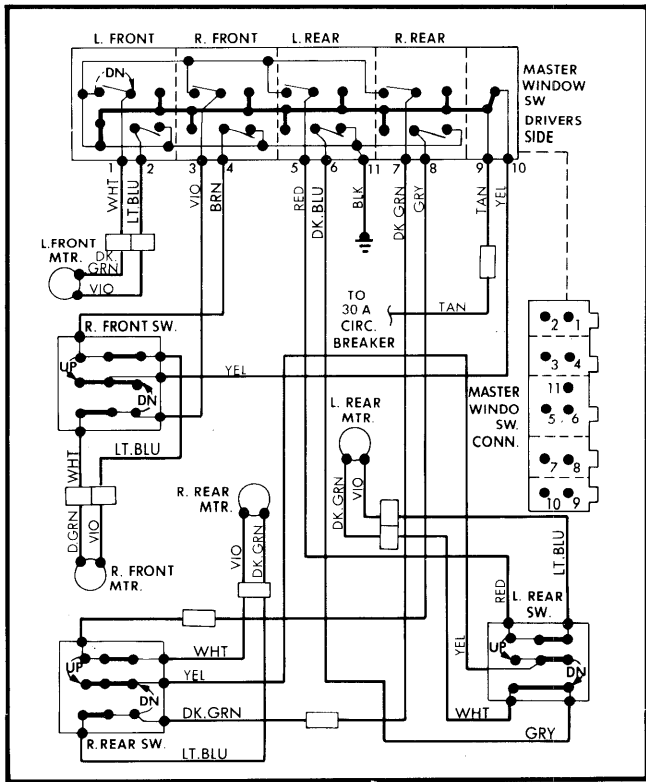

**Fig. 3 Chrysler Corp. Power Window Wiring Diagram (Gran Fury, Newport & Diplomat)**

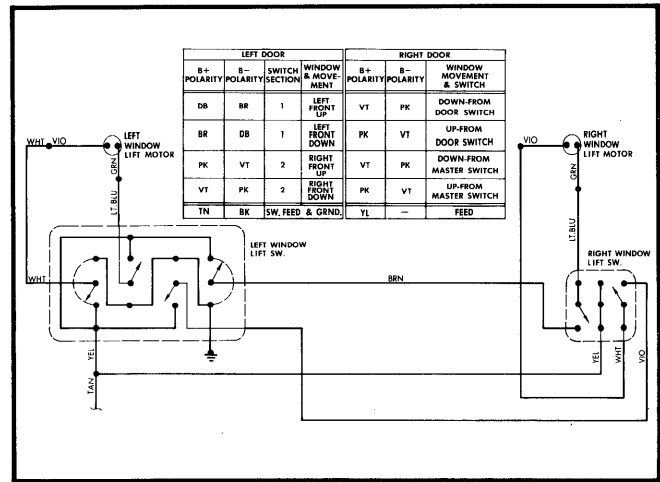

**Fig. 5 Chrysler Corp. Power Window Wiring Diagram (Imperial)**

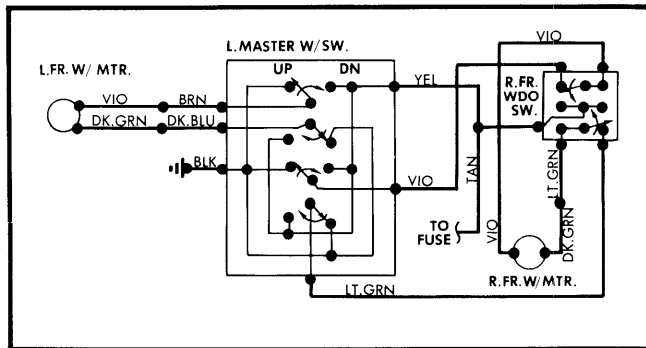

**Fig. 4 Chrysler Corp. Power Window Wiring Diagram (Cordoba & Mirada)**

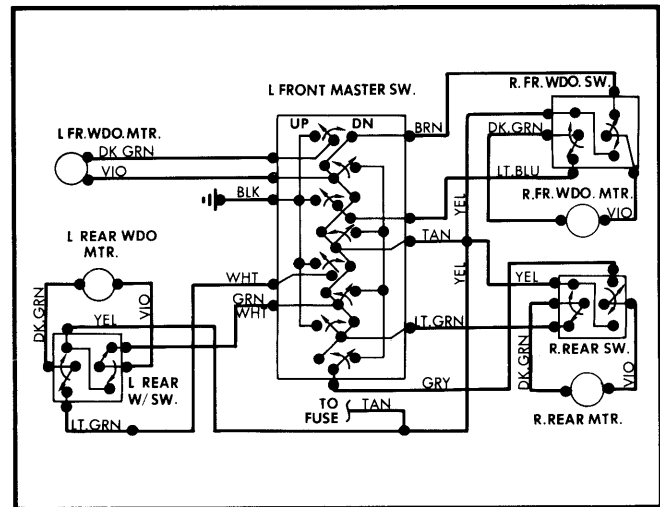

**Fig. 6 Chrysler Corp. Power Window Wiring Diagram (Aries, Reliant, LeBaron & 400)**