

Power Seats

FORD MOTOR CO. 6-WAY

Cougar, Granada,
Ford, Mercury
Lincoln Continental,
Town Car & Mark VI
Thunderbird, XR7

TESTING

DESCRIPTION & OPERATION

The 6-way power seat provides horizontal, vertical and vertical tilt adjustments. It consists of a reversible 3 armature motor, a switch and housing, vertical drive gears and horizontal rack and pinion drives. Electrical circuit is protected by a 20 amp. circuit breaker located in fuse block. Horizontal and vertical drive units are serviced separately, but the 3 armature motor is serviced as an assembly. Flexible shafts are serviced individually and can be removed by removing securing hose clamps.

NO SEAT MOVEMENT

The following checks can help isolate a defective component. Make checks in the sequence indicated.

- 1) Check circuit breaker feed and "out" side, then check circuit continuity from breaker to seat control switch.
- 2) Check connector and harness from control switch to motor. Check motor for a good ground connection.
- 3) Check for dirty or binding seat tracks and mechanical components.

SOME SEAT MOVEMENT

If the seat will adjust in one or more directions but not in all, current is available at control switch. Test for problems as indicated.

- 1) Test control switch for current "out" in each of the switch positions, using test charts provided. Wiggle the switch in each position to check for intermittent contact. Check wiring for continuity from control switch to motor.
- 2) Check for proper ground circuit at motor and seat assembly. Check each motor for rotation in both directions as current is applied to motor terminals. If any motor does not function, the entire motor assembly must be replaced.

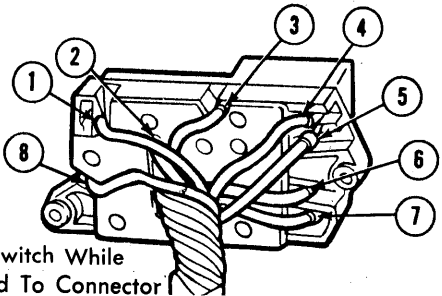

Test Switch While Attached To Connector

Switch Positions				
4-WAY KNOB	REAR TILT	FRONT TILT	POWER ①	GROUND ①
NEUT.	NEUT.	NEUT.	3 ONLY	1-2-4-5-6-7
FOREWARD	NEUT.	NEUT.	2-3	1-4-5-6-7-8
REARWARD	NEUT.	NEUT.	3-8	1-2-4-5-6-7
UP	NEUT.	NEUT.	3-4-6	1-2-5-7-8
DOWN	NEUT.	NEUT.	3-5-7	1-2-4-6-8
NEUT.	UP	NEUT.	3-6	1-2-4-5-7-8
NEUT.	DOWN	NEUT.	3-7	1-2-4-5-6-8
NEUT.	NEUT.	UP	3-4	1-2-5-6-7-8
NEUT.	NEUT.	DOWN	3-5	1-2-4-6-7-8

Use Self-Powered Test Light Or Ohmmeter

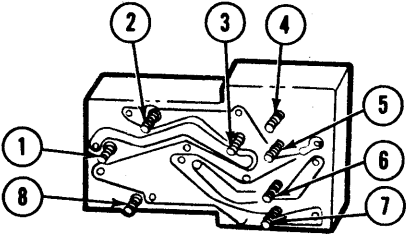

Switch Positions			
4-WAY KNOB	REAR TILT	FRONT TILT	CONTINUITY
NEUT.	NEUT.	NEUT.	1-2-4-5-6-7-8, 3 ISOLATED
FOREWARD	NEUT.	NEUT.	2-3, 1-4-5-6-7-8
REARWARD	NEUT.	NEUT.	3-8, 1-2-4-5-6-7
UP	NEUT.	NEUT.	3-4-6, 1-2-5-7-8
DOWN	NEUT.	NEUT.	3-5-7, 1-2-4-6-8
NEUT.	UP	NEUT.	3-6, 1-2-4-5-7-8
NEUT.	DOWN	NEUT.	3-7, 1-2-4-5-6-8
NEUT.	NEUT.	UP	3-4, 1-2-5-6-7-8
NEUT.	NEUT.	DOWN	3-5, 1-2-4-6-7-8

① — Terminal No. 1 is always grounded and terminal No. 3 is always power feed.

Fig. 1 Terminal Identification and Switch Test for Arm Rest Mounted Switches

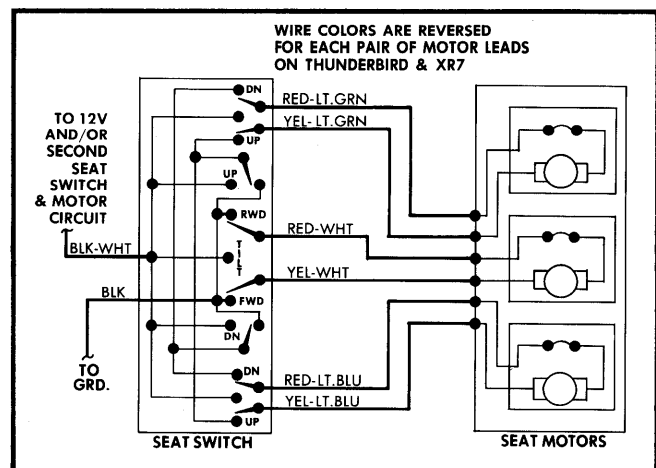

Fig. 2 6-Way Power Seat Wiring Diagram. Two Switches and Motors Used With Split Seats.

REMOVAL & INSTALLATION

SEAT TRACK & MOTOR

Removal — 1) Remove nuts or bolts retaining seat track to floor pan. Lift seat and detach motor wires. Remove 2 bolts attaching seat belts to floor and disconnect wiring connector.

2) Remove seat assembly from vehicle. Remove shields from end of cushion (if equipped) and remove bolts attaching track to seat frame.

FORD MOTOR CO. 6-WAY (Cont.)

3) Remove 3 motor-to-bracket bolts. Remove clamps retaining drive cables to seat tracks. Open wire restraining straps, and remove motor and cables from seat track assembly. Remove cable retaining brackets and drive cables from motor.

Installation — To install, reverse removal procedure, and check operation of seat in all directions.

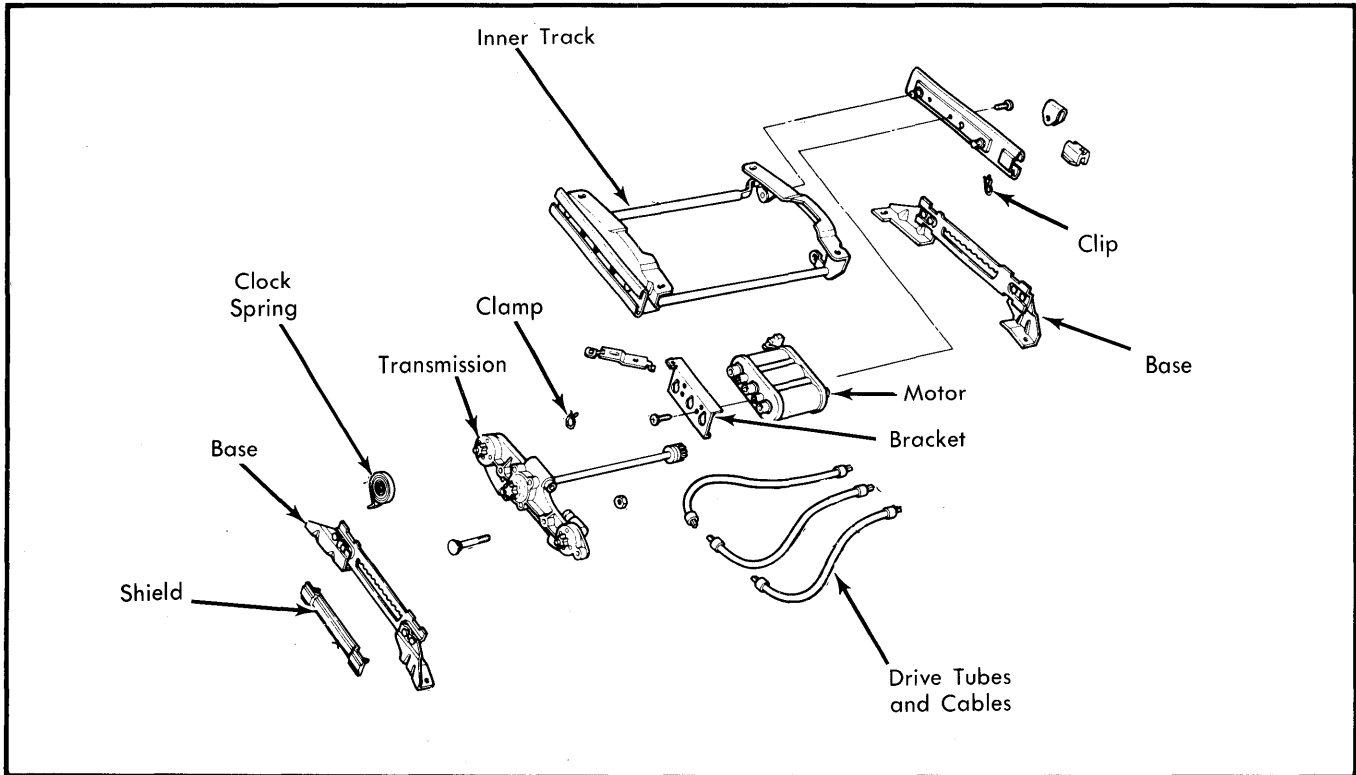

Fig. 3 Exploded View of 6-Way Power Seat Assembly