

Door & Tailgate Locks

FORD MOTOR CO. KEYLESS ENTRY

Lincoln Continental, Mark VI & Town Car
Thunderbird & XR7

DESCRIPTION & OPERATION

The keyless entry system enables the vehicle to be locked and unlocked without the use of a key. A row of buttons on the driver's door controls the system. Pressing the correct combination will unlock the driver's door and turn on the courtesy lights. Pressing other buttons opens all doors and the trunk lid, or locks all doors. The system will automatically lock all doors when the driver's seat is occupied, all doors are closed, the ignition is "ON", and the car is in gear.

System components include the door buttons, special wiring harnesses and a microcomputer/relay module. The module is located behind the right side cowl panel on Lincoln Town Car and Mark VI models, and below the rear package shelf on Lincoln Continental, Thunderbird and XR7 models. Also included in the system are power door locks and power trunk release.

NOTE — Servicing procedures for the door lock and trunk release components can be found in the appropriate article in this Section.

TROUBLE SHOOTING

Before testing the specific components of the keyless entry system, make sure the door lock motors and trunk release operate correctly when activated by manual switches. Check for binding linkages and poor wire connections. Lubricate and repair as necessary. The microcomputer/relay module cannot

be serviced and must be replaced as an assembly if inoperative.

TESTING

NOTE — Perform Quick Test to determine which component needs to be serviced, then perform Pinpoint Tests as directed. Do not make any other repairs until tests are completed and Quick Test has been repeated.

QUICK TEST

Ensure battery is fully charged, then disconnect and reconnect battery to reset system. If any of the specific complaints that follow seem to be the problem, go to the appropriate Pinpoint Test. If none of the following complaints are the problem, go to step 1).

Keyless Entry Problems & Tests

Complaint	Pinpoint Test/Step
Locks bind when man. operated	E1
No operation in freezing temp.	E7
Operates only with engine running	E8
Operates Intermittently	E6
No Illuminated Entry manually, but Operates with Keyless Entry	D1

1) Lock and unlock doors several times, using switches in each door. If all locks work normally, go to step 2). If not, go to Pinpoint Test E, Power Locks.

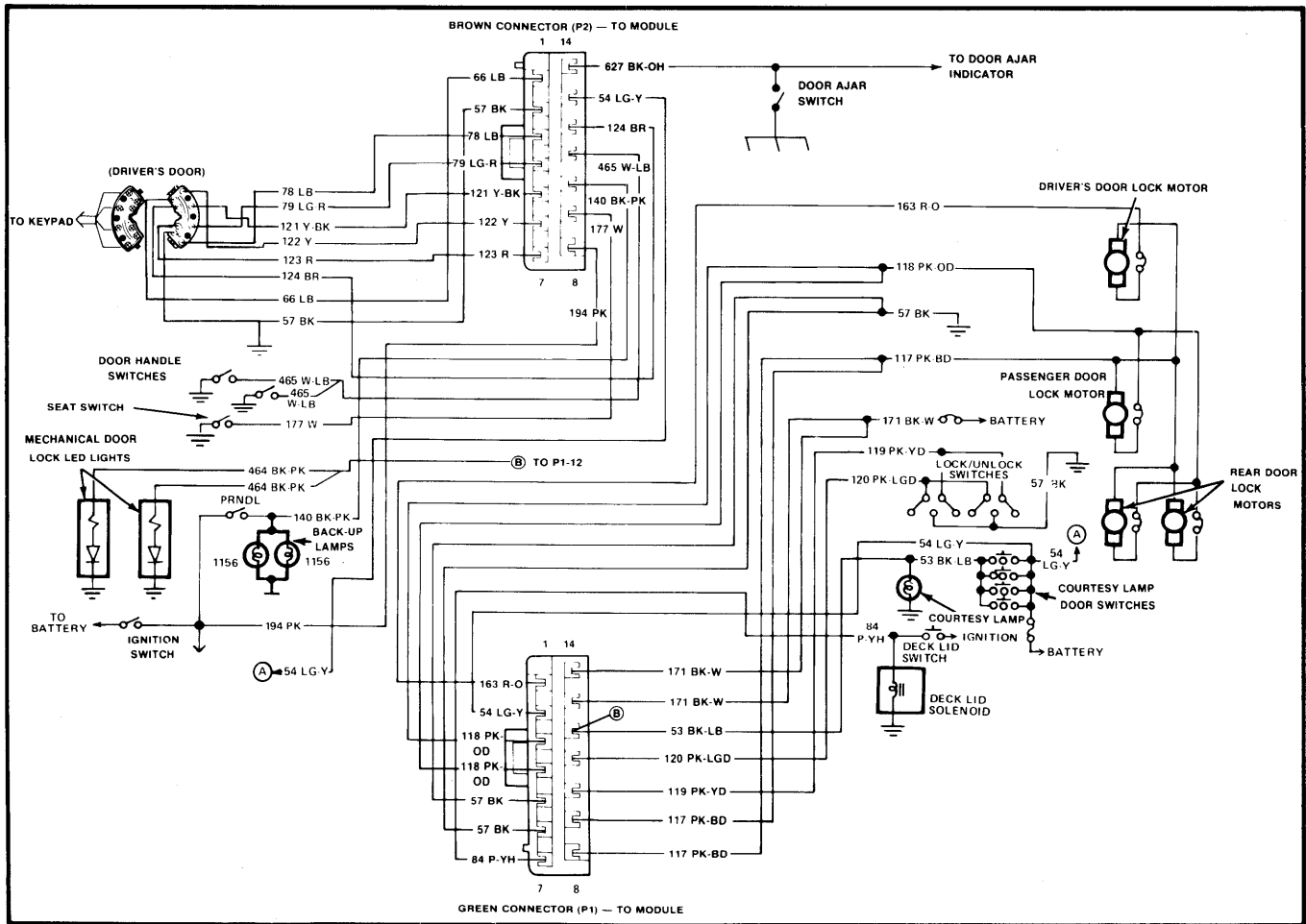

Fig. 1 Ford Motor Co. Keyless Entry System Wiring Diagram

FORD MOTOR CO. KEYLESS ENTRY (Cont.)

- 2) Press each button on Keyless Entry keypad. Wait for button to light, then go off, before pushing next button. If each button lights, go to step 3). If no buttons light, go to Pinpoint Test B, Keypad Illumination. If 1 or more buttons fail to light, go to Pinpoint Test C, Keypad Input.
- 3) With ignition off and key out of ignition lock, close all doors and trunk. Make sure all are unlocked, then press buttons 7/8 and 9/0 simultaneously. If all doors lock, go to next step. If some fail to lock, replace module and repeat Quick Test. If all doors fail to lock, go to Pinpoint test C1.
- 4) Unlock driver's door using code. If driver's door unlocks, go to next step. If driver's door fails to unlock, go to Pinpoint test C1.
- 5) Wait until light on keypad goes out, then re-enter code and press button 3/4 (within 5 seconds) to unlock other door(s). If other door(s) unlock, go to next step. If other door(s) fail to unlock, go to Pinpoint test C1, then repeat Quick Test.
- 6) Wait until light on keypad goes out, then re-enter code and press button 5/6 (within 5 seconds) to unlock trunk. If trunk unlocks, go to next step. If trunk doesn't unlock, go to Pinpoint Test F, Trunk Unlock. If trunk is always unlocked, go to step F5.
- 7) Sit in driver's seat, place transmission selector in "P", close all doors (unlocked), turn interior lights off, then turn ignition on. Move selector to "R", then "D". If all doors lock, go to next

step. If some doors fail to lock, go to Pinpoint Test A, Automatic Locking System.

8) Open driver's door, then close it. If door locks when closed, go to next step. If not, go to Pinpoint Test A, Automatic Locking System.

9) Open driver's door, then depress interior light switch on door jamb with foot. If door locks, go to A15. If door does not lock, go to next step.

10) Turn ignition off, place selector in "P" and remove key. Get out of car and close door, then press any keypad button. If interior lights and keyhole lights for both doors come on, go to next step. If not, go to Pinpoint Test D, Illuminated Entry.

11) Wait until interior lights go out, then press button to turn them on again. Within 5 seconds, press buttons 7/8 and 9/0 simultaneously to turn off lights. If lights go out, go to next step. If not, go to Pinpoint Test D.

12) With ignition off, transmission selector in "P" and driver's door closed, lift outside handle to open door. Within 25 seconds, get in and turn ignition on. If lights come on when handle is lifted and go off when ignition is turned on, go to next step. If lights come on, but do not go out, replace module and repeat Quick Test. If lights do not come on, go to Pinpoint Test D.

NOTE — In the following steps, no more than 5 seconds should elapse between successive key presses.

13) Enter code on keypad. Press button 1/2 to alert system to accept alternate code. Press the following buttons in sequence: 9/0, 7/8, 5/6, 3/4, 1/2. If keypad lights go out, go to next step. If lights stay on, replace module and repeat Quick Test.

14) Close and lock doors. Press the following buttons in sequence: 9/0, 7/8, 5/6, 3/4, 1/2. If driver's door unlocks, go to next step. If door stays locked, repeat steps 12) and 13). If no change, replace module and repeat Quick Test.

15) When all keypad lights are off, enter permanent code. Depress 1/2 button within 5 seconds, then wait until light goes out. Close and lock driver's door, then press the following buttons in sequence: 9/0, 7/8, 5/6, 3/4, 1/2. If doors remain locked, test is over. If some doors unlock, replace module and retest.

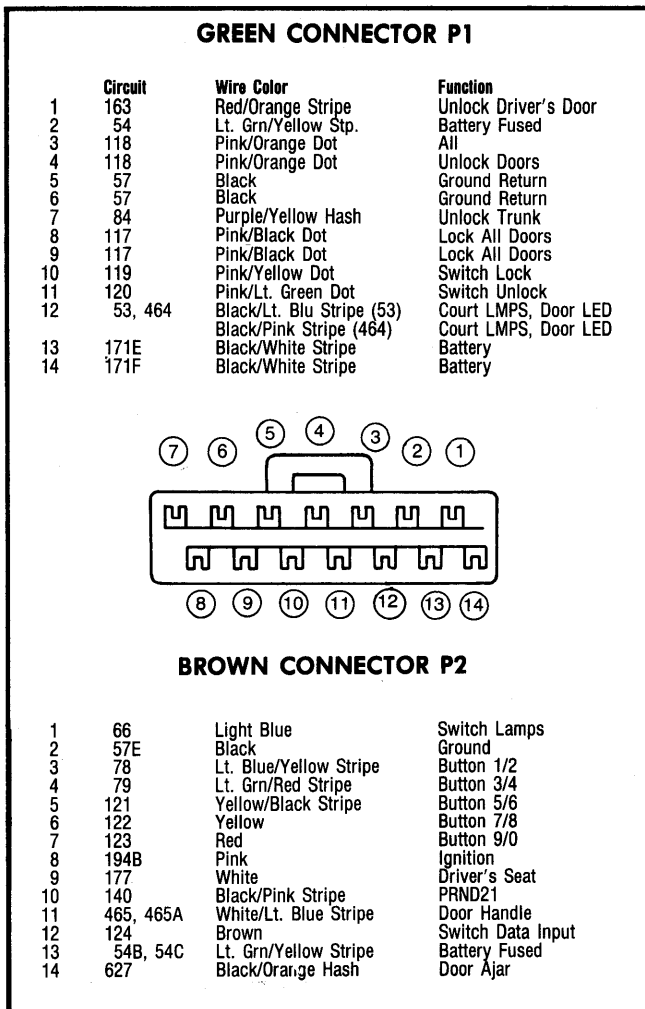

Fig. 2 Connector Terminal Identification

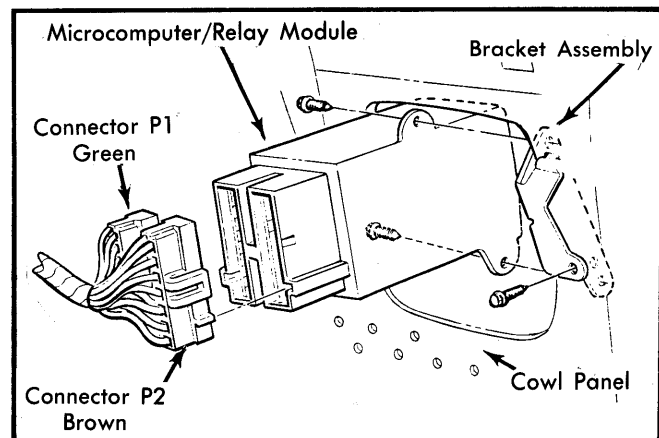

Fig. 3 Microprocessor/Relay Module Location Showing Brown and Green Connectors (Lincoln Continental, Mark VI & Town Car)

Door & Tailgate Locks

FORD MOTOR CO. KEYLESS ENTRY (Cont.)

PINPOINT TEST A AUTOMATIC LOCKING SYSTEM

This test checks driver's seat switch, courtesy lamps and switches, back-up light switch, keyless entry module and related circuits.

- 1) Check continuity between ground and pin 2 of module Brown connector. If continuity is present, go to next step. If not, repair circuit 57.
- 2) With ignition off, disconnect Brown connector. No continuity should be present between pins 9 and 2 when driver's seat is unoccupied. If no continuity, go to step 4). If continuity is found, go to next step.
- 3) Disconnect driver's seat switch and check for continuity between pin 9 of Brown connector and ground. If continuity, repair wiring and repeat Quick Test. If no continuity, replace seat switch and retest.
- 4) Have someone sit in driver's seat. Check continuity between pins 2 and 9 in Brown connector. If continuity is found, go to step 6). If not, go to next step.
- 5) With driver's seat occupied, check for continuity between Brown connector pin 9 and driver's seat switch connector. If continuity is found, replace seat switch. If no continuity, repair broken wiring. Retest for either situation.
- 6) Check voltage between pins 2 and 13 in Brown connector. If more than 10 volts, go to next step. If less than 10 volts, check power circuits 54B and 54C.
- 7) Check that the dome lights operate when each door jamb courtesy light switch is operated. If so, go to next step. If not, repair switch or wiring and retest.

8) Disconnect module Green connector. With all doors closed, check voltage at pin 12 of connector. If no voltage is present, go to next step. If voltage is present, replace door switch or wire that is shorted to battery voltage.

9) Repeat this test for each door: Open door and check voltage at Green connector pin 12. If readings indicate more than 10 volts with any door open, go to next step. If not, service circuits or switches and retest.

10) With ignition off, check voltage at pin 8 of Brown connector. If no voltage is present, go to next step. If voltage is measured, repair or replace ignition switch.

11) Turn ignition on, then check for voltage at Brown connector pin 8. If 10 or more volts are measured, go to step 13). If less than 10 volts, go to next step.

12) Turn ignition off, then check for short to ground in wire from pin 8 of Brown connector, and check for continuity between pin 8 and circuit 194B at ignition switch. If wiring is okay, go to next step, otherwise, service wiring or switch and retest.

13) Turn ignition on. Check for voltage at pin 10 of Brown connector. At least 10 volts should be present with transmission selector in "R", and no volts in any other position. If voltage readings are correct, replace module and retest. If voltage is present in a position other than "R", go to next step.

14) Test operation of Back-Up Light switch and check adjustment. Repair wiring or replace switch as necessary, then retest.

15) Connect ohmmeter between Brown connector pin 14 and ground. Lift outside door handle to open door latch, observe ohmmeter, then close latch with screwdriver. Resistance should be greater than 10,000 ohms with latch closed, and less than 10 ohms with latch open. If so, replace module and retest. If not, check door switch and retest.

PINPOINT TEST B KEYPAD ILLUMINATION

This test checks module, keypad and related circuits.

- 1) Check for at least 10 volts between ground and pins 13 and 14 of Green connector, then pin 13 of Brown connector. If voltage is okay, go to next step. If not, repair circuits or replace fuses and retest.
- 2) Check for continuity to ground between pins 5 and 6 of Green connector, then pin 2 of Brown connector. If okay, go to next step. If no continuity is measured, repair broken circuits and retest.
- 3) Disconnect keypad and Brown connector. Check for continuity between pin 1 of Brown connector and ground. If continuity is found, repair circuit and retest. If not, go to next step.
- 4) Connect keypad. Check resistance between pin 1 of Brown connector and ground. If less than 10 ohms, go to Pinpoint Test C. If over 10 ohms, go to next step.
- 5) Disconnect keypad, then measure resistance between pins 8 and 11 of keypad connector. If more than 10 ohms, replace keypad and retest. If under 10 ohms, go to next step.
- 6) Disconnect module Brown connector and keypad connector. Check continuity between Brown connector pin 1 and keypad connector pin 8. If circuit is open, repair wiring and retest. If okay, go to next step.
- 7) Check for continuity between keypad harness connector pin 11 and ground. If continuity is present, go to next step. If not, repair wiring and retest.
- 8) Check for short between pin 12 of Brown connector and ground. If shorted, repair and retest. If not, go to next step.
- 9) Check continuity between Brown connector pin 12 and keypad connector pin 10. If continuity is found, replace module and retest. If no continuity, repair wiring and retest.

PINPOINT TEST C KEYPAD INPUT

This test checks keypad, module and related circuits.

- 1) Disconnect module Brown connector and keypad connector. Determine which button has failed and check the appropriate circuit for a short to ground between keypad and Brown connector. If short is located, go to step 3) and retest. If okay, go to next step.
- 2) Reconnect keypad connector, then check for short between appropriate pin and pin 12 in Brown connector. If all okay, go to step 4). If short is located, replace keypad and retest.
- 3) Detrim door and disconnect keypad connector. Using above chart, check circuits that correspond to malfunctioning button for resistance less than infinity between keypad connector and ground or pin 12 in Brown connector. If low resistance is found, replace. If no low resistance is found, repair harness between module and keypad connectors and retest.
- 4) Verify that circuit between Brown connector pin 12 and keypad connector pin 3 is not broken or shorted to ground with 1/2 button depressed. If okay, go to next step. If not, repair and retest.
- 5) Connect Brown connector to module. Insert voltmeter lead into back of Brown connector at pin 1, then connect other lead to ground. Momentarily connect a jumper wire between pin 12 in back of Brown connector and pin for malfunctioning button. At least 5 volts should register on voltmeter for 5 seconds. If not, replace module and repeat Quick Test. If so, go to next step.
- 6) Remove inner door trim and disconnect keypad from its connector. Check resistance between pins 8 and 11 of keypad. If over 10 ohms, replace and retest. If under 10 ohms, go to next step.
- 7) Check for continuity between each pin in keypad. Pins 8 and 11 should have continuity; all other pairs should not. If any shorts are found, replace keypad and retest. If okay, go to next step.
- 8) Check for continuity, between pin 1 and 10 of keypad connector, with any button depressed. Then check between each pin (identified in chart at beginning of this test) and pin 10 as appropriate button is depressed. If continuity is present in all circuits, repair wiring. If continuity is not found when button is depressed, replace keypad and retest.

FORD MOTOR CO. KEYLESS ENTRY (Cont.)

PINPOINT TEST D ILLUMINATED ENTRY

This test checks lock cylinder LEDs, door handle switches, module and related circuits.

- 1) Check for continuity between ground and pin 2 of Brown connector. If present, go to next step. If no continuity, repair open circuit and retest.
- 2) With ignition off, press any button on keypad. If both keyholes light, go to step 5). If one or both don't light, go to next step.
- 3) Disconnect Green connector from module. Check for short between pin 6 and 12, then check continuity between pin 12 and connector at inoperative door cylinder. If okay, go to next step. If not, repair and retest.
- 4) Reconnect Green connector to module. Connect voltmeter between back of Brown connector pin 12 and ground. Lift up door handle (repeat for each door) and watch for 10 volts to appear on voltmeter within 15 seconds. If low or no voltage is measured, go to next step. If 10 volts are measured, replace cylinder and retest.
- 5) Check voltage between pin 13 of Brown connector and ground. If 10 volts or more, go to next step. If less than 10 volts, check fuse and wiring and retest.
- 6) Check for voltage at pin 8 of Brown connector with ignition switch both off and on. If 10 or more volts are present, only with switch on, go to next step. If any other voltage readings are obtained, repair short or break in circuits and retest.
- 7) Check for continuity between ground and Brown connector pin 11 as each door handle is lifted. No continuity should exist when handle is released. If handle is okay, go to step 10). If an open circuit exists with handle up or down, go to step 9). If continuity exists with handle released, go to next step.
- 8) Disconnect both door handle connectors and module Brown connector. Check for short to ground at Brown connector pin 11. If no continuity to ground, replace door switch and retest. If shorted to ground, repair and retest.
- 9) Check continuity between Brown connector pin 11 and connector to inoperative door handle switch. If no continuity, repair circuit and retest. If continuity exists, replace door switch and retest.
- 10) Reconnect both Brown and Green connectors at module. Turn ignition off and check voltage between ground and back of pin 12 in Green connector as door handle is lifted (wait for 30 seconds). If 10 volts are measured, go to next step. If less than 10 volts are measured, replace module and retest.
- 11) Momentarily connect a jumper across pins 2 and 12 of Green connector. If interior lights come on, go to next step. If not, repair circuits.
- 12) Check Green and Brown connectors for loose or broken pins. Repair if necessary, or replace connectors. If connectors are good, replace module. Repeat Quick Test.

PINPOINT TEST E POWER LOCKS

This test checks power door lock operation. The battery must be fully charged before beginning. Locate the specific problem in the following chart and go to the appropriate step.

Power Lock Servicing

Operation	Test Step
Linkage Needs Lubricating	1
No Locks Work	2
One or More Locks Do Not Work	3
One or More Switches Do Not Work	4
Locks Will Only Lock or Unlock	5
Locks Work Intermittently	6
Locks Do Not Work Below Freezing	7
Locks Work Only With Engine Running	8

1) Use spray lubricant to completely lubricate latch. If necessary, remove inner trim panel and spray complete linkage. Cycle lock 10 times or more, and check for interference.

2) Check the following items in the door lock system:

- Circuit Breaker 14.
- At least 10 volts at Green connector pin 13, even while locks are operated.
- Continuity to ground at Green connector pins 5 and 6.
- Correct mechanical operation of door lock switches.
- Check for short to ground at Green connector pins 10 and 11.

If any problems are located, correct and retest.

3) Manually cycle locks several times to check operation. Remove trim panel and check voltage at actuator while locking and unlocking door. If more than 10 volts, replace actuator. If less than 10 volts, go to module and insert voltmeter probes into back of Green connector at pin 8 and ground, then pin 1 and ground while pressing lock button. Voltage should be 0 when button is not depressed; 10 or more when depressed. If not, replace module and retest.

4) Turn ignition off, remove door panel trim at bad switch, disconnect Green connector at module, and then check continuity between Green connector pin 10 and Lock terminal of door switch. Then check between pin 11 and Unlock terminal. Finally, check continuity between ground and ground terminal of lock switch. If all circuits have continuity, replace lock switch. If not, repair circuits.

5) With ignition off, disconnect Green connector. Check continuity to ground from pins 10 and 11 when pressing Lock (pin 10) and Unlock (pin 11) at one of the door switches. Then check for voltage at pins 8 and 3 while pressing Lock (pin 8) and Unlock (pin 3). If no continuity to ground, repair circuits. If less than 10 volts are measured, replace module. If more than 10 volts are measured repair wiring to door.

6) Check continuity of module ground connections. Measure between ground and pins 5 and 6 of Green connector. If resistance is measured, clean or repair ground connections.

7) Bring vehicle into heated garage to thaw, then lubricate locks as in step 1). Perform Quick Test.

8) Check battery condition and linkage of all locks to eliminate binding. Repair any corroded or loose connections. If system is not fully operative, perform Quick Test.

PINPOINT TEST F TRUNK UNLOCK

This test checks module, trunk release solenoid, and related circuits.

- 1) With ignition on, press trunk release button in glove box. If trunk unlocks, go to next step. If not, go to step 3). If trunk is always unlocked, go to step 5).
- 2) Disconnect Green connector at module and check continuity between pin 7 and trunk release solenoid. If good, replace module and retest. If no continuity, repair circuits and retest.

3) Check operation of solenoid using jumper wires and battery. Replace solenoid if defective. Repeat Quick Test.

4) Check operation of circuit breaker 14 and replace if defective. Repeat Quick Test.

5) Check for shorted module. Remove module Green connector and see if trunk solenoid locks. If so, replace module. If not, go to next step.

6) Disconnect glove box switch (with Green connector still disconnected). If trunk locks, replace glove box switch and retest. If not, repair short to battery in circuit 84 and repeat Quick Test.

Door & Tailgate Locks

FORD MOTOR CO. KEYLESS ENTRY (Cont.)

REMOVAL & INSTALLATION

KEYBOARD ASSEMBLY

Removal — Remove interior door trim panel. Disconnect keyboard electrical connector. Remove keyboard retaining assemblies (Lincoln) or 2 retaining nuts (Thunderbird and XR7). Remove actuator and cable assembly.

Installation — To install, reverse removal procedure.

MICROPROCESSOR

Removal — Remove retaining screws and lower module. Disconnect electrical connectors and remove module.

Installation — To install, reverse removal procedure.

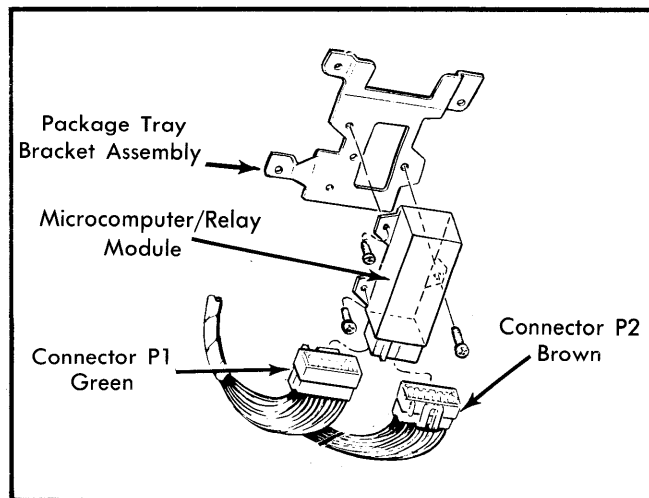

Fig. 4 *Microprocessor/Relay Module Location Showing Brown and Green Connectors (Thunderbird & XR7)*