

Door & Tailgate Locks

FORD MOTOR CO.

All Models (Except Escort, EXP, LN7 & Lynx)

DESCRIPTION

Power door lock system is controlled by door rocker switches or power door lock push buttons. Relays are used on Fairmont, Zephyr, Granada and Cougar models. All other models have power supplied directly to the switches and door lock motors. Ford and Mercury station wagon models have a tailgate lock controlled by the same switches as the regular doors.

TESTING

MOTOR TESTS

Apply 12 volts to one terminal of the motor actuator connector and ground the other terminal. The motor should finish its travel in 1 second or less. Reverse the leads and retest. Using an ammeter, check current draw, which should not exceed 6 amps.

SWITCH TESTS

Door Lock Push Button — Using a self-powered test lamp or ohmmeter, there should be no continuity between terminals when switch is in normal position. Continuity should exist between "A" and "B" with switch held in one direction and between "B" and "C" with switch in the other direction.

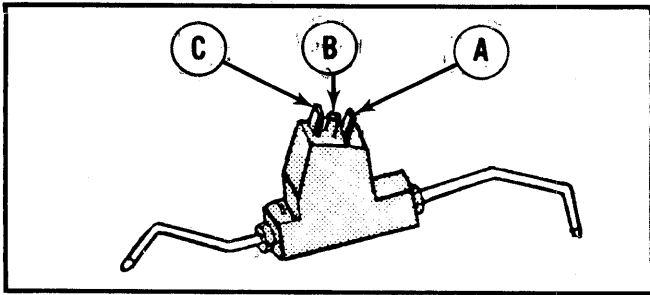

Fig. 1 Door Lock Push Button Switch Terminal Identification

Rocker Switch Type — Procedure for testing this type of door lock switch is the same as testing a single power window switch. See Ford Power Windows article in this section.

RELAY TESTS

Remove both connectors to perform relay tests. Relays are located in right front cowl panel. Verify that terminal "1" on each relay is grounded. If not grounded, check relay case-to-ground bolts for tightness. If relay ground bolts are tight and terminals "1" of each relay still do not ground, replace relay. Apply power to terminals "2" and "4" on each relay and connect a 12 volt test light between terminals "1" and "2" and ground (no longer than two minutes). Test light should come on; if not, replace relay.

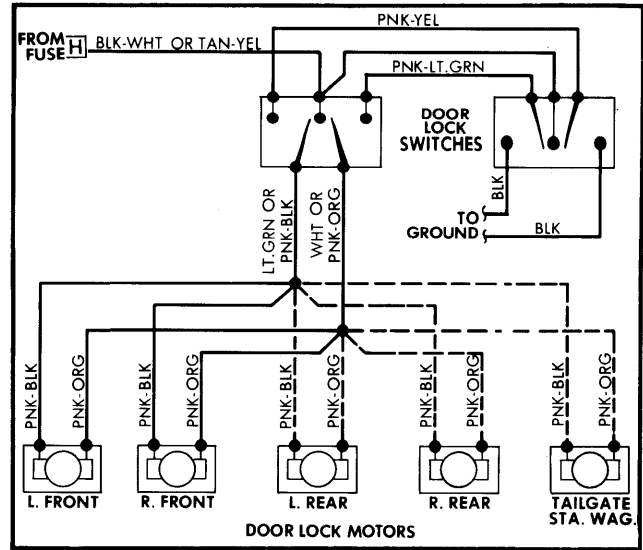

Fig. 2 Power Door Lock Wiring Diagram (Capri, Ford, Lincoln Continental, Mercury, Mustang, Thunderbird & XR7)

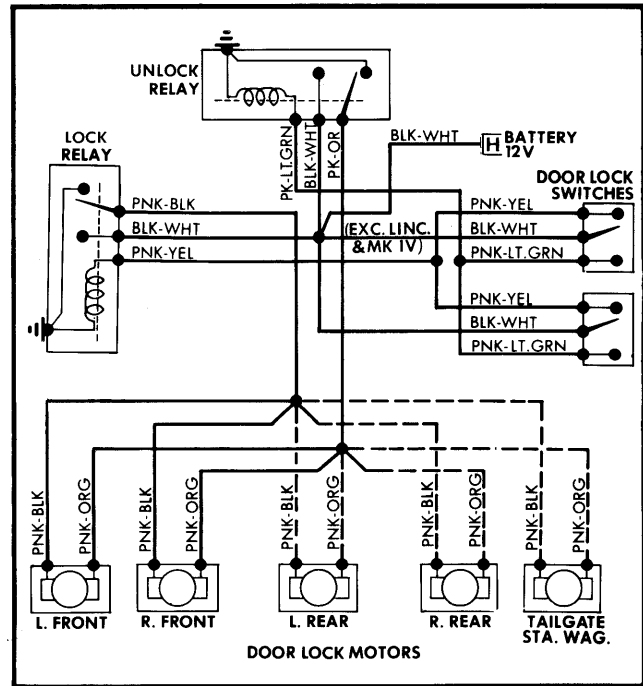

Fig. 3 Power Door Lock Wiring Diagram (Cougar, Fairmont, Granada, Lincoln Town Car, Mark VI & Zephyr)

REMOVAL & INSTALLATION

ELECTRIC DOOR LOCK ACTUATOR

Removal (All Models) — Remove door trim panel and water shield. Disconnect actuator motor link from door latch. Remove screws or drill out rivets attaching actuator motor to door, and disconnect wiring connector. Remove motor.

FORD MOTOR CO. (Cont.)

Installation — To install, reverse removal procedure.

DOOR LOCK SWITCH

Removal (Capri & Mustang) — Pry out switch bezel from top and bottom. Pry housing tabs apart and disconnect wiring and switch.

Installation — To install, reverse removal procedure.

Removal (Cougar, Fairmont, Granada & Zephyr) — Power door lock switch is an integral part of door lock push button rod. Remove door trim panel and water shield. Detach rod from door latch and bellcrank, then disconnect wiring connector.

Installation — To install, reverse removal procedure.

Removal (Ford, Lincoln Town Car, Mark VI & Mercury) — If switch is on door panel, remove armrest, switch mounting plate and switch. If switch is on armrest, remove handle cup inside armrest and disconnect lock rod by pressing down. Remove attaching screw, switch plate, nuts and switch.

Installation — To install, reverse removal procedure.

Removal (Lincoln Continental) — **1)** On left front door, remove end screw securing housing assembly. On right front door, remove screw from under ashtray lid. On rear doors, remove 2 screws from under ashtray lid.

2) Using small screwdriver under screw end of housing, carefully pry end of housing up until housing can be removed from armrest. Remove screw(s) retaining connector to housing. Carefully pry switch from connector.

Installation — To install, reverse removal procedure.

Removal (Thunderbird & XR7) — **1)** If switch is on door panel, remove bezel screw and tilt bezel up. Remove bezel-to-connector screws and unplug switch.

2) If switch is on armrest remove door handle, 2 cover screws, and lift cover up and off. Remove switch plate, connector screws and switch.

Installation — To install, reverse removal procedure.

TAILGATE LOCK ACTUATOR

Removal (Ford & Mercury) — Remove tailgate trim panel and water shield. Drill out rivet retaining motor to inner panel. Disconnect wiring and detach motor from rod.

Installation — To install, replace motor and secure with bolt or rivet.