

Cruise Control Systems

AMERICAN MOTORS CRUISE COMMAND

DESCRIPTION

System senses car speed through speedometer cable and uses engine intake manifold vacuum to regulate accelerator and to automatically maintain any pre-set cruising speed above 30 MPH as selected by the driver.

OPERATION

Cruise Command control is an integral part of the directional switch lever and consists of two separate switches. The first is "OFF-ON" and "RES" (resume) slide switch located on the flat of the directional control lever. Second is a push button "SET" switch on the end of the lever. To engage system, move slide switch to "ON" position, accelerate to desired speed (at least 30 MPH) and depress and release "SET" button. System will now maintain speed until brake pedal is depressed or slide switch is moved to "OFF" position. If disengaged by brake pedal, system may be re-engaged to previously selected speed by accelerating to 30 MPH and moving slide switch to "RES" position, then releasing switch.

NOTE — "OFF" position erases memory and cancels pre-set speed of "RES" function.

A higher speed can be set by pressing on accelerator until new speed is reached, then press and release "SET" button. A lower speed can be achieved by depressing "SET" button until car slows to desired speed, then releasing button to maintain new speed. Individual components operate as follows:

Sensor — The electronic speed sensor is installed between the upper and lower speedometer cables and provides electrical signals to the regulator.

Regulator — The regulator prevents operation below 30 MPH and supplies electrical signals to the vacuum operated servo which controls the throttle position. Regulator is suspended on a bracket behind the headlight switch.

Servo — Servo is controlled by regulator and uses manifold vacuum to convert it into motion. On 4 cylinder models, a bead-link chain connects servo cable to throttle linkage. On 6 cylinder models, a cable with an integral link at the throttle end connects servo to throttle linkage.

Release System — The release system de-energizes Cruise Command in two ways. By depressing the brake pedal, an electrical signal is sent through the regulator to the servo where the vacuum supply valve closes and the dump valve opens, admitting atmospheric pressure into the servo, ensuring immediate servo release. Pushing the slide switch to "OFF" also deactivates Cruise Command.

TROUBLE SHOOTING

SYSTEM WILL NOT ENGAGE IN "ON" POSITION

No vacuum or restricted lines. Control switch, regulator, or speed sensor inoperative. Brake switch wiring and adjustment incorrect.

RESUME INOPERATIVE

Bad servo ground, control switch inoperative.

SYSTEM RE-ENGAGES WHEN BRAKE IS RELEASED

Defective regulator. Dump valve adjustment or hose routing. Brake switch adjustment.

DISENGAGES WITHOUT APPLYING BRAKE

Loose wiring or vacuum connection, broken servo linkage or brake switch.

DOES NOT RETURN TO IDLE

Improper linkage adjustment.

LOSES SET SPEED SLOWLY

Vacuum leak in hose or dump valve.

ROAD SPEED VARIES MORE THAN 2 MPH

Centering adjustment incorrect.

TESTING

The following diagnostic tests determine the cause of the malfunction and corrective steps required.

CONTROL SWITCH CONTINUITY

Disconnect the 4-wire connector from the control switch. Connect a jumper wire from a 12 volt source to the RED wire in the connector. Use a 12 volt test lamp to check for continuity in switch. Connect one end to ground, then touch probe to switch connector terminals. Lamp should light as indicated in following chart.

Control Switch Continuity	
Switch Position	Terminals with Power
OFF	None
ON	Green, Brown
RESUME/ACCEL	All
BUTTON PRESSED	Yellow, Brown

CIRCUITRY TESTS

Using test lamp, check following terminals of regulator connector. See Fig. 2. Verify each terminal is installed in correct location.

Switch OFF—Key OFF — Should have NO light at all terminals.

- If light at 14, 10 or 5, check control switch.
- If light at 13, reverse pink and blue wire connection at brake light switch.
- If light at 7, wire is connected to wrong fuse. Connect to accessory fuse.

Switch OFF — Key ON — Should light at 7.

- If no light at 7, check accessory fuse and connections.

Switch ON — Key ON — Light at 5, 7 and 14.

- If no light at 5 and 14, check control switch.
- If no light at 7, check accessory fuse and connection.

AMERICAN MOTORS CRUISE COMMAND (Cont.)

Switch ON – Key OFF – Light at 5 and 14.

- If no light, check control switch.

Switch in RES – Key OFF – Light at 5, 10 and 14.

- If light at 10 does NOT go out when RES released, replace control switch.

SET button depressed – Key OFF – Should light at 5 and 10, go out at 10 when SET released.

- If not, verify wire positions.
- If correct, check control switch.

Brake pedal depressed – Should light at 13.

- If no light, check for loose connector at brake switch, blown fuse or defective brake switch.

ADJUSTMENTS

CENTERING ADJUSTMENT

Adjustment is made by turning centering adjustment screw on regulator. See Fig. 1.

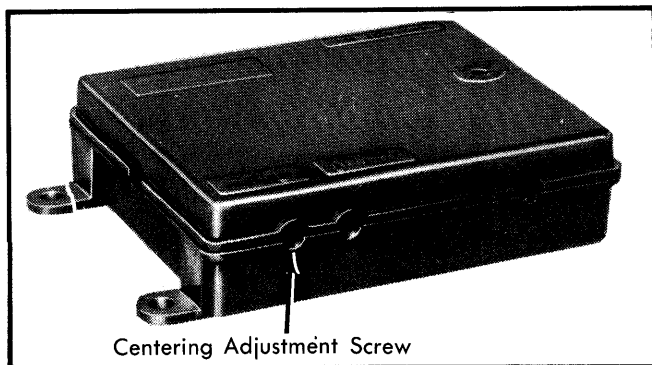

Centering Adjustment Screw

Fig. 1 Regulator Showing Centering Adjustment

1) Turn screw counter-clockwise a small amount if speed control engages at two or more MPH higher than selected speed.

2) Turn screw clockwise a small amount if speed control engages at two or more MPH below selected speed.

NOTE – Check for proper centering on level road after each adjustment.

VACUUM DUMP VALVE

To adjust dump valve, depress brake pedal and move valve toward bracket on pedal as far as possible.

REMOVAL & INSTALLATION

ENGAGEMENT SWITCH

Removal – 1) Remove lower steering column cover. Disconnect harness connector under dash panel. On tilt column models, remove wires from connector, fold back two wires and tape to harness. Attach string to wire harness.

2) Remove switch assembly from dimmer switch by pulling straight out. Carefully pull wire harness up and out of column. Remove string.

Installation – To install, reverse removal procedures.

SERVO

Removal – Remove retaining nuts and cable housing from servo. Remove cable connecting clip. Disconnect vacuum hoses. Remove retaining nut and servo from bracket. Note position of ground wire. Disconnect harness and carefully thread through dash panel. Remove servo.

Installation – To install, reverse removal procedure.

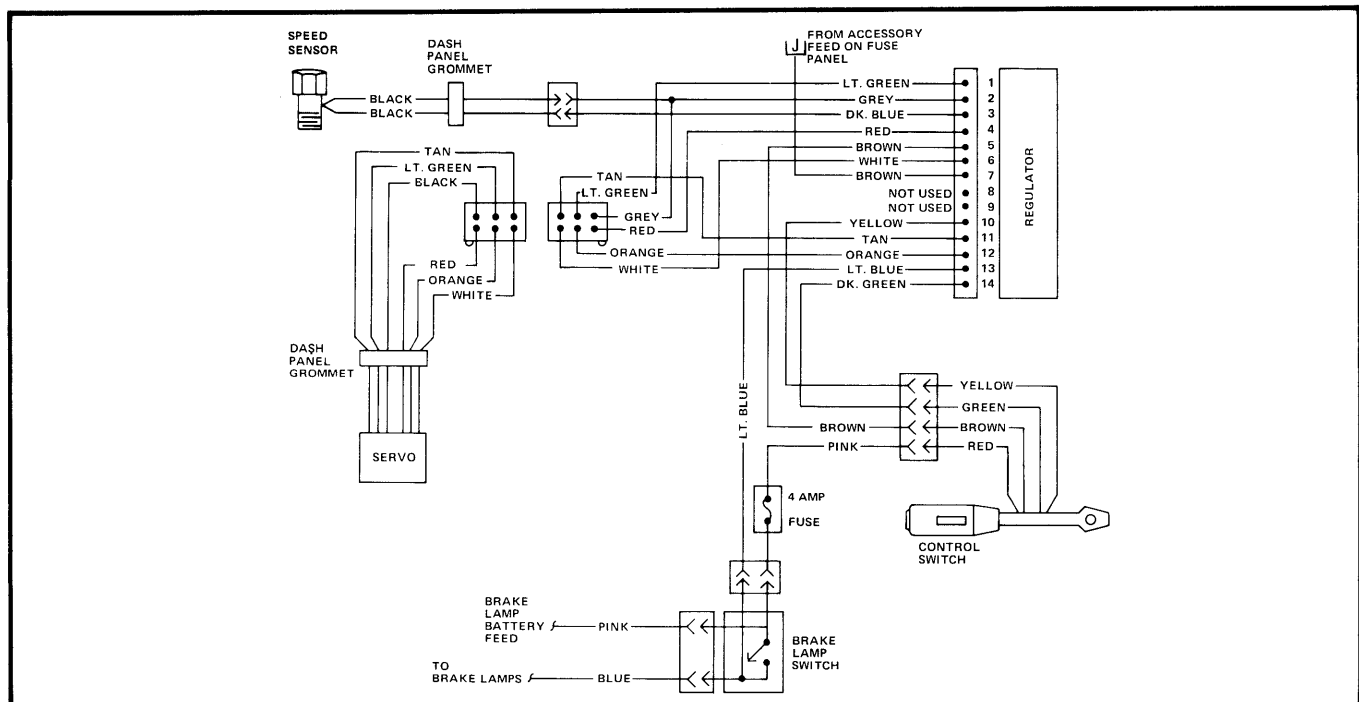

Fig. 2 Cruise Command Schematic