

Wiper/Washer Systems

FORD MOTOR CO. CONCEALED SYSTEM

Ford, Mercury
Lincoln Town Car, Mark VI

DESCRIPTION & OPERATION

Two wiper systems are available. One is a standard high/low speed wiper system, the other is a high/low/intermittent system. All systems use a 2-speed permanent magnet motor with a brush end plate at one end and a gear housing on the other. The park switch is located in the gear cover and the park mechanism is located in the output arm. Wiper switch is located on steering column, and power is supplied by a circuit breaker in fuse panel.

Intermittent operation is controlled by a variable resistor in the switch and an electronic governor. The pause duration can be from 2 to 12 seconds and is controlled by rotating pause control knob at the end of the lever. Washer switch is integral with wiper switch and is activated by pulling lever toward driver.

TESTING

WIPER MOTOR CURRENT DRAW

Motor can be tested on bench, or on car with linkage disconnected. Connect ammeter as shown. Connect a jumper wire from battery negative terminal post to low speed terminal on motor end plate and read current draw. Connect jumper to high speed terminal and read current draw. In both cases, draw should not exceed 3.5 amps.

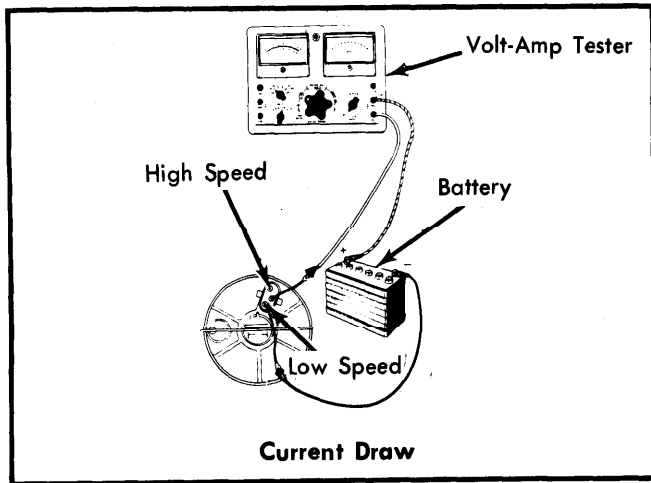

Fig. 1 Motor Current Draw Test Connections

MOTOR PARK TEST

1) Ignition switch must be on for all tests. With system operating in "Low", turn switch off with wiper blades in straight-up position. Blades should complete cycle and return to position below windshield. If not, check as follows.

2) Remove connector and check for battery voltage at circuit 65. See Fig. 2. If voltage is not present, service circuit as required. If voltage is present, check ground. If ground is poor, check switch cover screw, and motor ground strap for tightness.

3) If ground is good, remove motor connections and check for continuity between circuits 28 and 56 in wiring harness. If no continuity, service circuit. If continuity exists, check for ground at circuit pin 28 on motor. If open, service park switch.

4) If ground exists, check for continuity between circuits 61 and 63 in wiring harness. If continuity exists, check for continuity between circuit pins 63 and 65 on motor. If open, replace wiper switch.

5) If no continuity exists between circuits 61 and 63 in wiring harness, check for continuity between terminals "P" and "G" on wiper switch. If no continuity, replace switch. If continuity exists, replace governor.

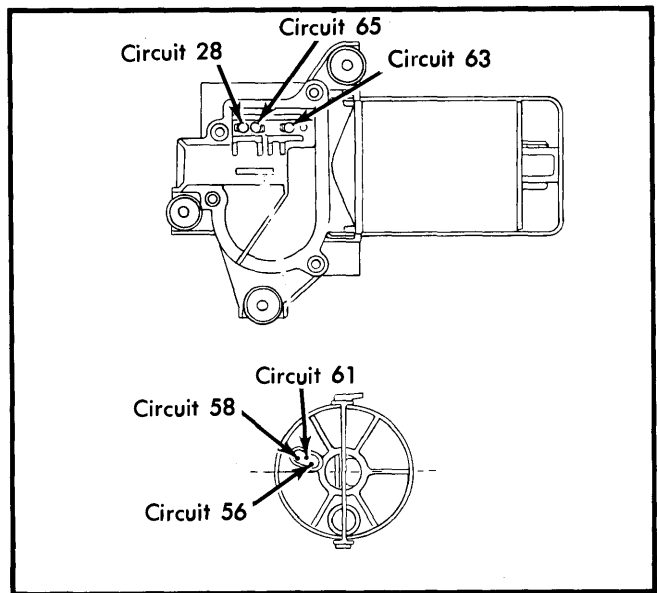

Fig. 2 Circuit Connections for Motor Park Test

WIPER SWITCH CONTINUITY TEST

Check wiper switch for continuity using following chart. Disconnect connector under steering column and test with self-powered test light or ohmmeter. (Ohmmeter required for intermittent wiper test). If switch does not show required continuity, or poor continuity exists in any position, replace switch.

NOTE — See wiper switch connector terminal identification in Fig. 3.

Wiper Continuity Test		
Position	Standard Wiper	Interval Wiper
OFF	C-D, F-L	F-L, P-G
LOW	B-C, G-L	R-L-G
HIGH	B-C, G-H	R-H-G
INTER		⊙L-G, G-R
WASH	B-W	B-W

⊙ — Resistance between G-R should vary between 420 and 13,000 ohms.

Wiper/Washer Systems

FORD MOTOR CO. CONCEALED SYSTEM (Cont.)

REMOVAL & INSTALLATION

WIPER MOTOR

Removal - Disconnect battery, then remove wiper linkage cover. Disconnect linkage arm by removing retaining clip. Disconnect wiring, remove 3 mounting bolts, and remove motor.

Installation - Be sure motor arm is in "PARK" position, then reverse removal procedure.

WIPER SWITCH & INTERMITTENT GOVERNOR

Removal - Disconnect battery, then remove steering column cover. Remove 2 wiper switch screws, disconnect wiring, and remove switch. Disconnect wiring from governor, remove 2 screws and governor.

Installation - To install, reverse removal procedure.

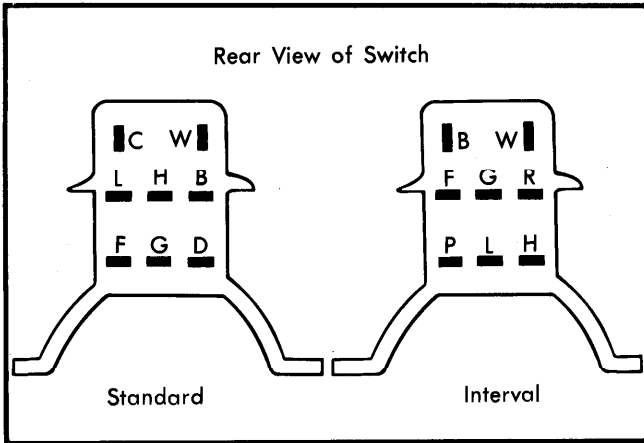

Fig. 3 Wiper Switch Continuity Test Terminal Locations

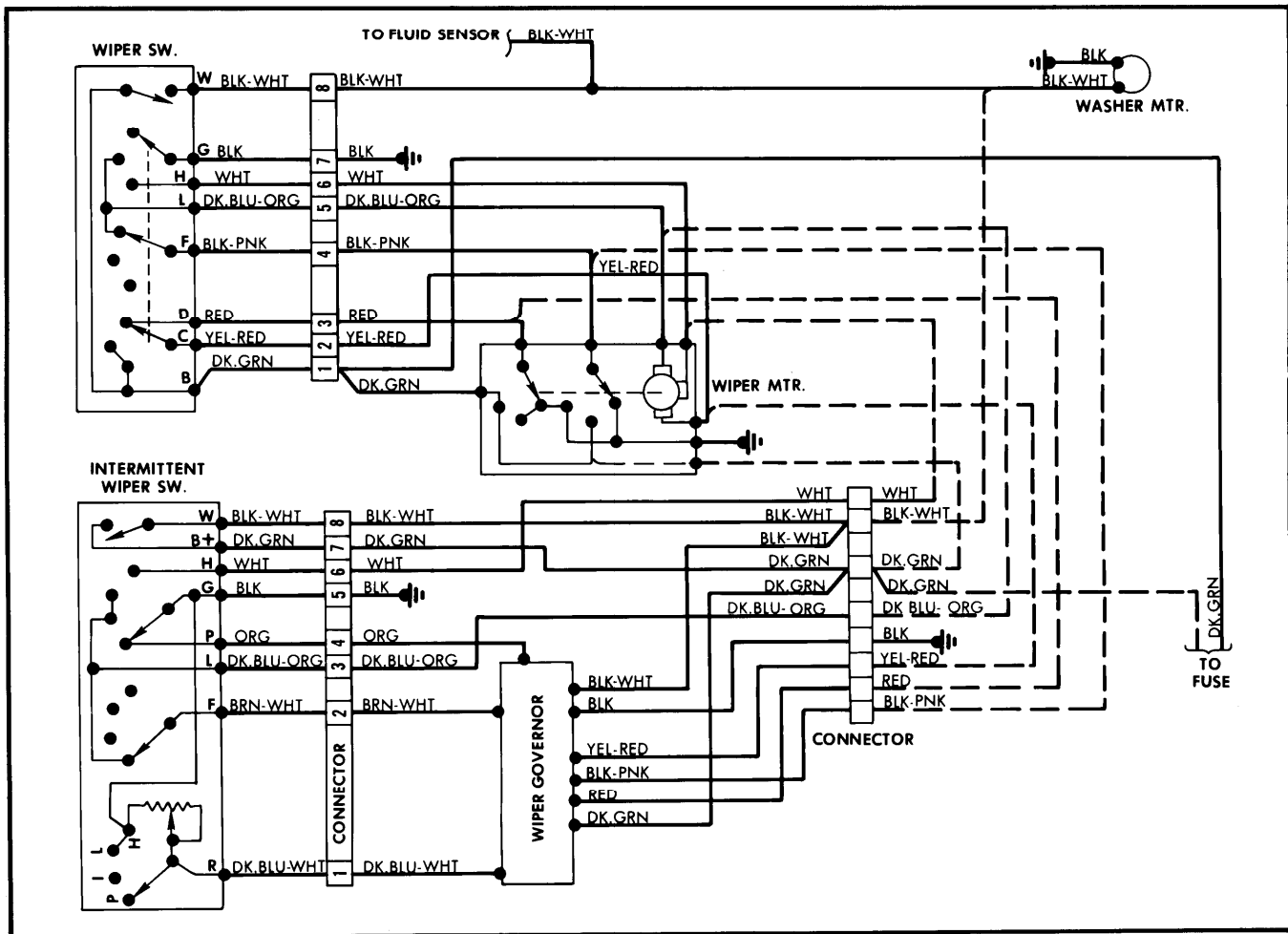

Fig. 4 Concealed Wiper System Wiring Diagram (Ford, Mercury, Lincoln Town Car & Mark VI)