

Speed Control Systems — Automatic

FORD MOTOR CO.

All Models

DESCRIPTION

The speed control system consists of operator switches, an amplifier assembly, a servo assembly, vacuum dump valve, speed sensor, wiring harness and vacuum hoses. Models with electronic dashboard use a special connection to the speedometer in place of a speed sensor. Manual transmission vehicles also include a clutch switch.

Control switches are located in the steering wheel. The control amplifier is below the dashboard on the driver's side. The servo assembly is in the engine compartment, while the brake and clutch switches are located on the brake pedal support bracket below the dashboard.

OPERATION

This system is operational at speeds above 30 MPH. When the "ON-OFF" switch is set to the "ON" position and the driver depresses and releases the "SET - ACC" button, the vehicle speed will be maintained until a new speed is set by the driver, the brake or clutch pedal is depressed, or until the system is turned off. When the system has been de-activated by depressing brake or clutch pedal, the driver can re-establish set speed by pressing and releasing the "RESUME" switch.

TROUBLE SHOOTING

Check all electrical and vacuum connections. Press brake pedal to see if brake lights work. If not, repair brake light circuit. Check clutch switch on manual transmission vehicles. Check servo and throttle linkage for free operation. If components appear to be in good condition, proceed to the following tests.

TESTING

CONTROL SWITCHES

Disconnect 6-way connector at amplifier assembly. Turn ignition "OFF". Connect ohmmeter between Lt. Blue-Black lead and ground. Make the following tests while rotating steering wheel:

- 1) Depress the "OFF" switch and check for reading from 0 to 1 ohm.
- 2) Depress "SET/ACCEL" and check for a reading from 646 to 714 ohms.
- 3) Depress "COAST" and check for a reading from 114 to 126 ohms.
- 4) Depress "RESUME" (if equipped) and check for a reading from 2090 to 2310 ohms.

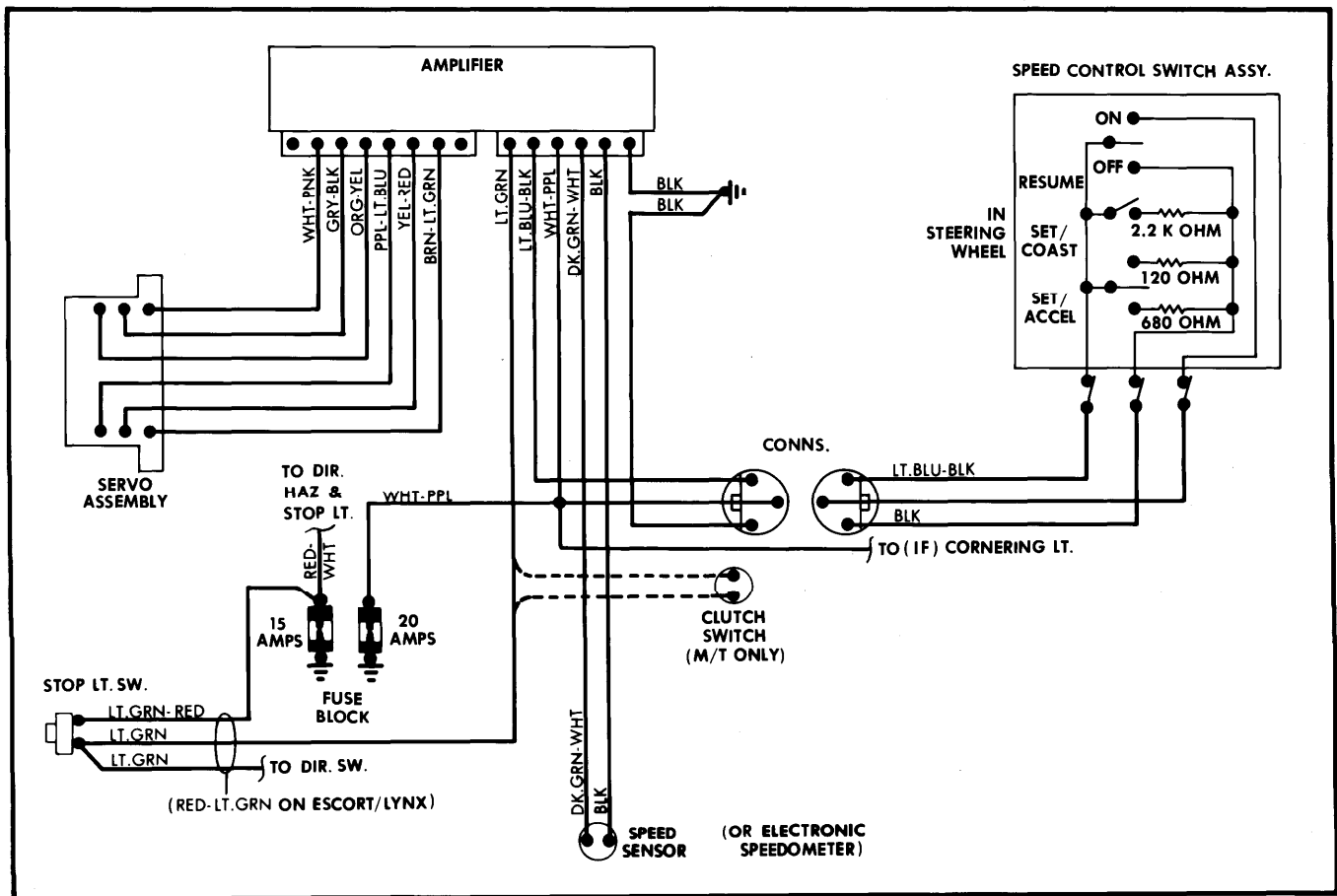

Fig. 1 Automatic Speed Control Wiring Diagram (All Models)

FORD MOTOR CO. (Cont.)

If resistance values are okay but meter needle fluctuates, remove steering wheel and clean contact surfaces of speed control ground brush and turn signal brush. If resistance readings are high, check switch assemblies and ground circuit in steering column.

SPEED SENSOR (EXC. ELECTRONIC SPEEDOMETER)

Disconnect speed sensor connector and connect an ohmmeter between wire connector terminals (Dk Grn/White stripe and Black) at speed sensor end. A reading of 30-100 ohms (40 ohms for Escort and Lynx) should be obtained. A reading of 0 ohms indicates a shorted coil, and a high reading indicates an open coil. If reading is within proper range and speedometer operates properly, sensor is probably good. Substitute a new sensor if necessary to check operation.

SPEED SENSOR (ELECTRONIC SPEEDOMETER)

Models with electronic speedometer do not use a separate speed sensor, but are connected directly to the speedometer itself. To test, raise and support the rear of vehicle so wheels can turn. Connect an AC voltmeter to the Dark Green-White lead and ground at the amplifier. With speedometer indicating 30 mph, voltmeter should read approximately 6 volts.

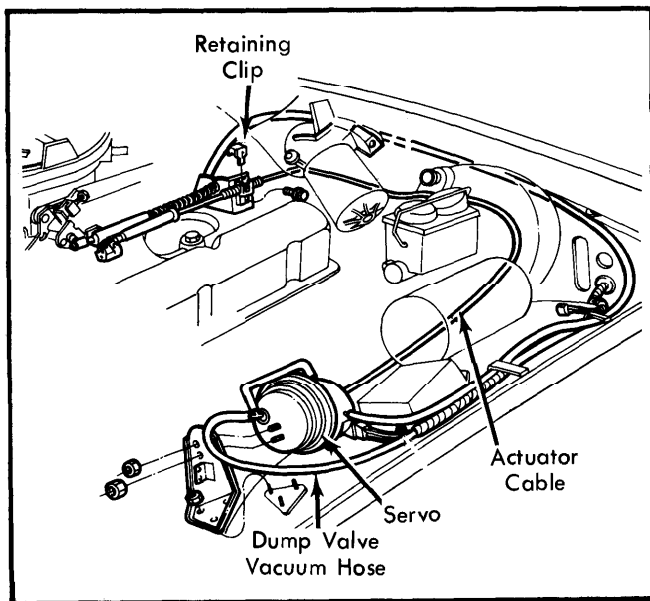

**Fig. 2 Automatic Speed Control Components
Typical Cable Installation**

SERVO ASSEMBLY

CAUTION — If Orange-Yellow lead is shorted to either White-Pink or Grey-Black leads it may be necessary to replace the amplifier.

- 1) Separate servo-to-amplifier connector. Connect an ohmmeter between Orange-Yellow and Grey-Black wires at servo connector. Resistance should be 40-125 ohms.
- 2) Connect ohmmeter between Orange-Yellow and White-Pink wire leads. Resistance should be 60-190 ohms.

- 3) Start engine. Jumper Orange-Yellow lead of servo connector to battery positive post and White-Pink lead of servo connector to ground. Momentarily touch Grey-Black lead of servo connector to ground. Servo throttle actuator should tighten bead chain to open throttle. Throttle should hold in that position, or slowly release chain tension. If White-Pink wire is removed from ground, servo should immediately release tension on chain.

AMPLIFIER

CAUTION — DO NOT use a test light to perform amplifier tests because too much current draw will damage electronic components. Use only a voltmeter of 5000 ohm/volt rating or higher.

- 1) Make the following tests at the amplifier 6-way connector. Turn ignition on and connect voltmeter between White-Purple stripe wire and ground in connector. Battery voltage should be present.
- 2) Connect voltmeter to Lt. Blue-Black wire and ground. With "ON" switch in steering wheel depressed, battery voltage should be present. If not, perform control switch test.
- 3) Release "ON" button. Voltmeter should read 7.8 volts. If not, check system ground, wiring, fuse and circuit breaker. Install a known good amplifier and recheck, if necessary.
- 4) Depress "OFF" switch. Voltage should drop to zero. If not, perform control switch test. Install a known good amplifier and recheck, if necessary.
- 5) Depress and hold "SET-ACC" switch. Voltmeter should read 4.5 volts. Rotate steering wheel several times. If voltage varies more than 0.5 volts, check switch.
- 6) Depress and hold "COAST" button. Voltage should be 1.5 volts. Depress and hold "RESUME" button. Voltage should be 6.5 volts. If all readings are correct, test servo assembly.

VACUUM DUMP VALVE

Vacuum dump valve is a redundant safety feature which releases servo vacuum whenever brake pedal is depressed. To test, disconnect dump valve vacuum hose at servo, connect hand vacuum pump to hose and apply vacuum. If vacuum will not hold, hose or dump valve leaks and should be replaced or adjusted. Step on brake pedal. If vacuum is not released, adjust or replace dump valve.

CLUTCH SWITCH

NOTE — Do not use a test lamp to test clutch switch. Use a voltmeter with 5000 volt/ohm rating or higher.

Disconnect switch pigtail connector from speed control harness connector and connect an ohmmeter to 2 switch connector terminals. With clutch pedal released, resistance should be less than 5 ohms. With clutch pedal depressed, circuit should be open. If not, replace switch.

FORD MOTOR CO. (Cont.)

ADJUSTMENTS

LINKAGE

Bead Type Chain — Adjust bead chain so chain is tight when engine is at hot idle. On vehicles with throttle positioner, adjust chain with positioner disconnected.

Actuator Cable Type — Disengage throttle positioner and set carburetor at hot idle speed. Remove cable retaining clip, pull on actuator cable to take up any slack and insert cable retaining clip.

VACUUM DUMP VALVE

Adjust dump valve (located at brake pedal) by moving it in its mounting bracket so there is no vacuum leak when brake pedal is in non-depressed position and vacuum leak when pedal is depressed. Apply vacuum with hand vacuum pump.

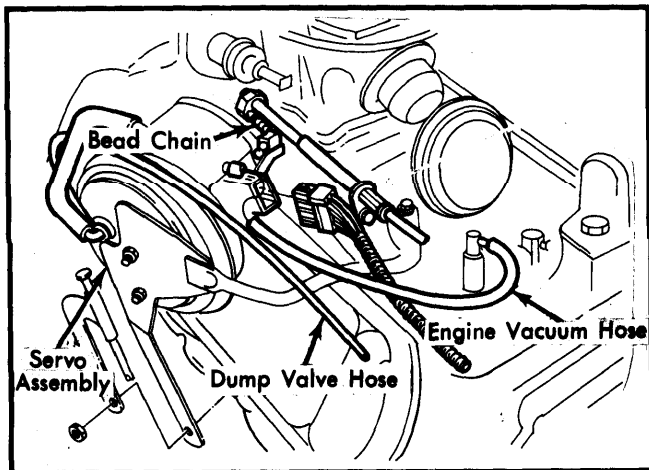

Fig. 3 Automatic Speed Control
Typical Bead Chain Installation

REMOVAL & INSTALLATION

SERVO ASSEMBLY

Removal (All Models) — 1) Remove air cleaner. Remove retaining clip from actuator cable, or bead chain. Disconnect actuator cable from accelerator cable. Remove vacuum and electrical connections from servo.

2) Remove servo mounting bracket screws. Carefully remove servo and cable assembly. Remove 2 nuts holding cable cover to servo, pull off cover and remove cable or bead chain assembly, and remove servo.

Installation (All Models) — To install, reverse removal procedures.

AMPLIFIER

Removal (All Models) — Remove screws securing amplifier to mounting bracket. Disconnect electrical connections to amplifier and remove amplifier.

Installation (All Models) — To install, reverse removal procedures.

SPEED SENSOR

Removal (All Models) — Disconnect electrical connector to sensor. Disconnect upper and lower speedometer cables at sensor. Remove sensor.

Installation (All Models) — To install, reverse removal procedures.

ENGAGEMENT SWITCH

NOTE — See *STEERING COLUMN SWITCHES* article in *Steering* Section for engagement switch Removal and Installation procedures.