

Headlight Doors — Automatic

5-33

ACCESSORIES & EQUIPMENT

Chrysler
Dodge

CHRYSLER CORP.

DESCRIPTION

Headlamp doors are electrically operated by a single motor mounted behind the center grille. The motor is series wound with two field windings, and has a worm gear drive and internal limit switches. The relay circuit breaker assembly is mounted on the right side of the steering column support on all models except Imperial. Imperial relay circuit breaker is located on the fuse block.

OPERATION

When headlight switch is turned on, relay is energized completing motor circuit, and doors are rotated to the open position. When doors reach the open position, a limit switch cuts off power to motor. When headlight switch is turned off, relay completes door closing circuit, and doors are rotated to the closed position. When doors reach the closed position, a second limit switch cuts off power to motor.

EMERGENCY OPERATION

If headlight doors do not open when headlight switch is turned on, doors can be opened manually as follows: Raise hood and disconnect motor leads, then rotate the hand wheel (located at

lower end of motor) clockwise until headlight doors are fully opened.

CAUTION — Do not rotate wheel after doors reach end of travel as damage to motor may result.

TESTING

MOTOR

1) Disconnect wire connector from motor to body connector. Connect one lead of a voltmeter to the negative battery terminal and the other lead to the female side of the body wiring connector.

2) With ignition and headlight switches on, there should be 10-13 volts at the female connector. Move test lead to male terminal. With ignition on, and headlight switch "OFF" there should be 10-13 volts at male connector.

3) If proper voltages are present, replace motor. If proper voltages are not present, check wiring, headlight switch, motor relay and circuit breaker.

4) If cycling occurs with ignition on and headlight switch in both "ON," and "OFF" positions, replace motor. If cycling occurs with ignition on, and headlight switch in either the "ON," or "OFF" position, check that torsion bar and motor output gear are properly aligned.

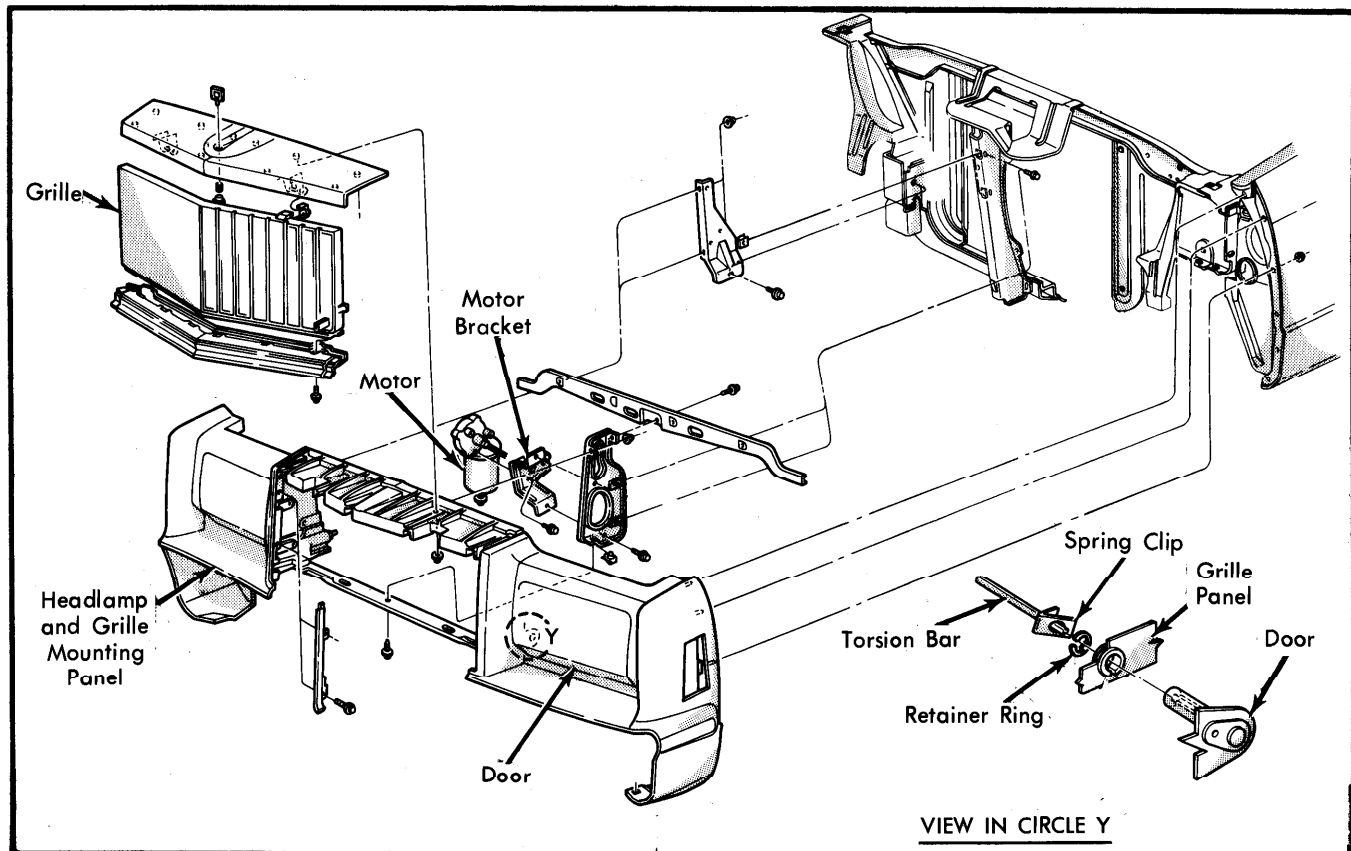

Fig. 1 Chrysler New Yorker Headlight Door Assembly
(Imperial and Dodge Models Similar)

Headlight Doors — Automatic

CHRYSLER CORP. (Cont.)

REMOVAL & INSTALLATION

TORSION BAR & MOTOR

Removal — Torsion bar and motor are removed as an assembly. Disconnect battery ground cable and motor leads (including ground wire) from harness. On Imperial models, remove front grille. Rotate handwheel on motor until doors are at halfway open position. Compress and remove clips from crank assemblies and remove torsion bar from slotted areas in cranks. Remove motor mounting bracket from vertical lock support and remove torsion bar and motor as an assembly.

Installation — 1) On all models except Imperial, position motor on mounting bracket and install screws. On all models, insert torsion bar in motor and position clips on bar.

2) Position motor assembly on vertical lock brace and tighten attaching screws. Position and seat torsion bar in slotted areas of cranks. Compress clips and position over cranks and torsion bar. Connect motor wiring and battery ground cable. Check motor operation. Replace grille on Imperial.

HEADLIGHT DOORS

Removal — 1) Disconnect motor leads at harness connector. Rotate motor with hand wheel until doors are in half-open position. Remove clip from headlight door crank and torsion bar.

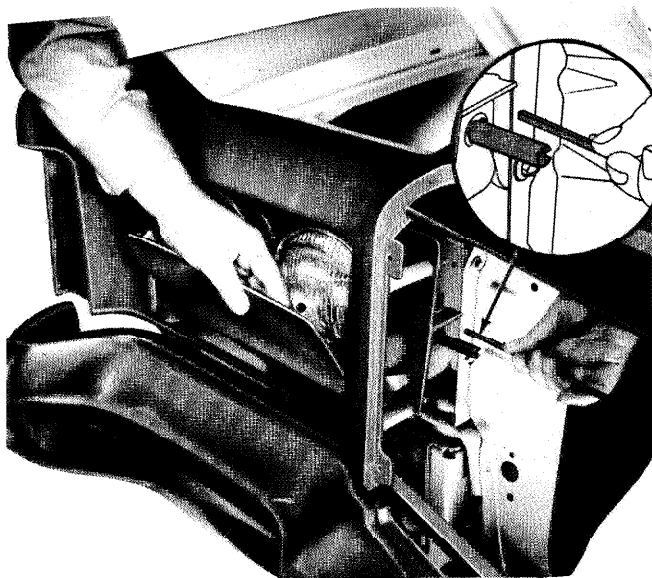

Fig. 2 Removing Torsion Bar

2) Remove torsion bar by pulling with one hand and moving headlight door with the other. Disconnect headlight wiring. Remove inboard sealed beam unit and retainer clip from crank assembly on all except Imperial.

3) On New Yorker, remove headlight door crank from door by removing attaching screw from inside door reinforcement. Remove idler pin from housing. On St. Regis, remove parking and turn signal lamps. On New Yorker and St. Regis, slide door outward to remove from housing.

4) On Imperial, with headlight wiring disconnected, remove door trim panel, both headlights and headlight trim panels. Loosen screw in collar off inside headlight door crank. Remove 2 screws on inboard bracket and slide bracket with collar off crank.

5) Remove screw holding crank to door and remove crank from door. Remove outboard pivot pin and remove headlight door.

Installation — Reverse removal procedure and note the following: Before installing torsion bar in slotted area of crank, make sure motor is in half-open position. To check installation, operate doors several times and check for interference between doors and front panel. If interference exists, loosen headlight housing mounting nuts and readjust assembly until interference is eliminated. With all components properly installed, re-aim headlamps.

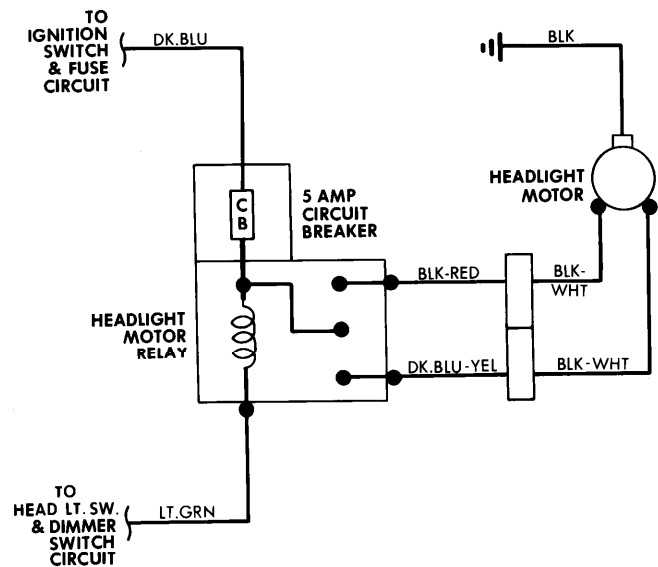

Fig. 3 Wiring Diagram of Chrysler Headlight Door Circuit