

# Headlight Dimmers — Automatic

FORD MOTOR CO.

Lincoln Town Car  
Mark VI

## DESCRIPTION & OPERATION

The automatic headlight dimmer is a driver-operated device which automatically switches headlights from high to low beam in response to light from oncoming vehicles. Major components of the system are as follows:

**Sensor Amplifier** — Unit is located behind grille on driver's side of vehicle. Unit combines a light-sensing optical device and transistorized amplifier in one unit. Sensitivity is adjusted at the factory and unit is sealed in epoxy to prevent further adjustment.

**Power Relay** — Provides heavy duty contacts for switching headlight beams. Relay contains a diode for damping purposes to protect sensor amplifier. Observe proper polarity when connecting relay to prevent diode damage.

**Sensitivity Control** — Driver sensitivity control is large bezel on the headlight switch. Rotating it clockwise increases sensitivity and headlights will switch when cars are farther away. Counterclockwise rotation decreases sensitivity, allowing approaching cars to come nearer before headlights dim. Full counterclockwise position permits manual operation of headlight beams with column dimmer switch.

**Dimmer Switch** — The dimmer switch used is a special override type located in the steering column. One position provides low beam operation; the other is automatic operation. Moving the lever half-way between positions allows the driver to flash the high beams.

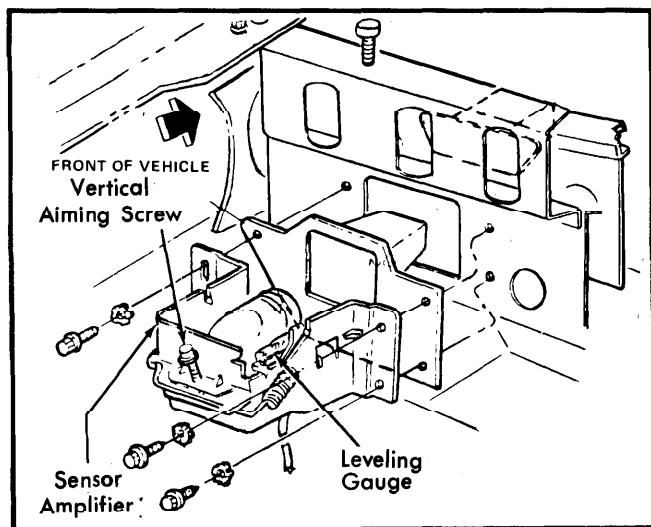

Fig. 1 Sensor-Amplifier Adjustment

## ADJUSTMENT

### SENSOR-AMPLIFIER VERTICAL AIMING

Sensor Amplifier vertical aiming should be performed with car unloaded, trunk empty, gas tank at least half full, and tire pressure correct. Put car on a level floor and rock vehicle to

equalize springs. Adjust vertical aiming screw at rear of the bracket assembly, until the bubble is centered in the level.

**NOTE** — Do not tamper with the screw at the end of level. Always make final adjustment while turning aiming screw clockwise.

## TROUBLE SHOOTING

### HEADLIGHTS STAY ON LOW BEAMS

Sensor level needs adjustment. Defective sensor amplifier. Defective relay or dimmer switch. Wiring problem.

### HEADLIGHTS STAY ON HIGH BEAM

Dirty sensor lens or chamber. Fuse blown. Defective sensor amplifier. Bad relay ground. Defective relay or dimmer switch.

### HEADLIGHTS DIM TOO SOON OR LATE

Driver control adjustment. Dirty sensor lens or chamber. Level adjustment. Defective adjustment control. Defective sensor amplifier.

### NO MANUAL LOW BEAM OR HIGH BEAM FLASH

Defective dimmer switch. Wiring short.

### FUSE BLOWS CONSTANTLY

Defective sensor amplifier. Defective adjustment control. Defective wiring harness.

## TESTING

### PREPARATION FOR TESTS

The transistorized unit needs no warm-up time. Place car in a lighted area, adjust sensitivity control to a central position, and operate engine at a fast idle to maintain constant voltage.

### TEST PROCEDURE

- 1) Turn headlight switch on. Headlights should remain on low beam in both positions of the dimmer switch. If not, make test A.
- 2) Place dimmer switch in "AUTOMATIC" position. Slight movement of the lever should override unit and make high beams flash. If not, make test B.

### TEST A (FUSE, DIMMER SWITCH, POWER RELAY, AMPLIFIER, DRIVER CONTROL)

- 1) Check for a loose connection at dimmer switch, power relay, connector near driver control, or in-line fuse or wiring harness.
- 2) Disconnect sensor amplifier connector. Connect a test lamp between ground and Yellow wire in female connector. If lamp does not light, check for blown fuse or loose connections.
- 3) Connect a test lamp between battery and White wire. Rotating the driver control counterclockwise to off should light

## FORD MOTOR CO. (Cont.)

test lamp. If not, check for loose connections or damaged driver control.

4) To test driver control, connect voltmeter between ground and White wire. With control at full clockwise position, battery voltage should be present. With control at counterclockwise position (but not off), voltage should be 3 volts or less. With control off, no voltage should be present. Replace control if readings are incorrect.

5) Connect test lamp between battery and Gray/Yellow wire in connector. Operate dimmer switch several times. Test lamp should light in one position, and low beams should be on in both positions. If not, check loose connections, poor ground at dimmer relay, or damaged relay and dimmer switch.

6) If steps 1) through 5) do not locate problem, sensor amplifier is at fault and should be replaced.

### TEST B (OVERRIDE CIRCUIT)

- 1) Check for disconnected Red wire at dimmer switch.
- 2) Disconnect White wire from dimmer switch connector and ground it. If upper beams light, replace dimmer switch. If not, reconnect wire.
- 3) Connect test lamp between battery and White wire at sensor amplifier connector. Test lamp should light when dimmer lever is moved slightly toward driver. If lamp does not light, check continuity between switch and connector. If lamp does light, replace sensor amplifier.
- 4) Place dimmer switch in "AUTOMATIC" position and cover sensor lens with a black cloth. High beams should come on. If not, disconnect sensor. If high beams then come on, replace sensor amplifier.
- 5) If lights came on in step 4), place switch in automatic lower beam and rotate driver control fully counterclockwise. Headlights should switch to high beam. If not, check driver control for poor ground connection.
- 6) If system responded to preceding test satisfactorily, system is operating properly. Check aiming and sensitivity for final adjustments.

## REMOVAL & INSTALLATION

### DIMMER SWITCH

Disconnect battery ground cable. Remove steering column shroud and disconnect dimmer switch lever by pulling out of

switch with a twisting motion. Peel back foam from switch, remove connectors and screws and remove switch. To install, reverse removal procedure.

### POWER RELAY

Disconnect battery ground cable. Remove left hand kick panel and remove relay by removing mounting screw. To install, reverse removal procedure.

### SENSOR-AMPLIFIER

Disconnect battery ground cable and wiring harness at rear of sensor assembly. Remove screws and lockwashers, and remove sensor amplifier from vehicle. Ensure sensor lens is clean. To install, reverse removal procedure.

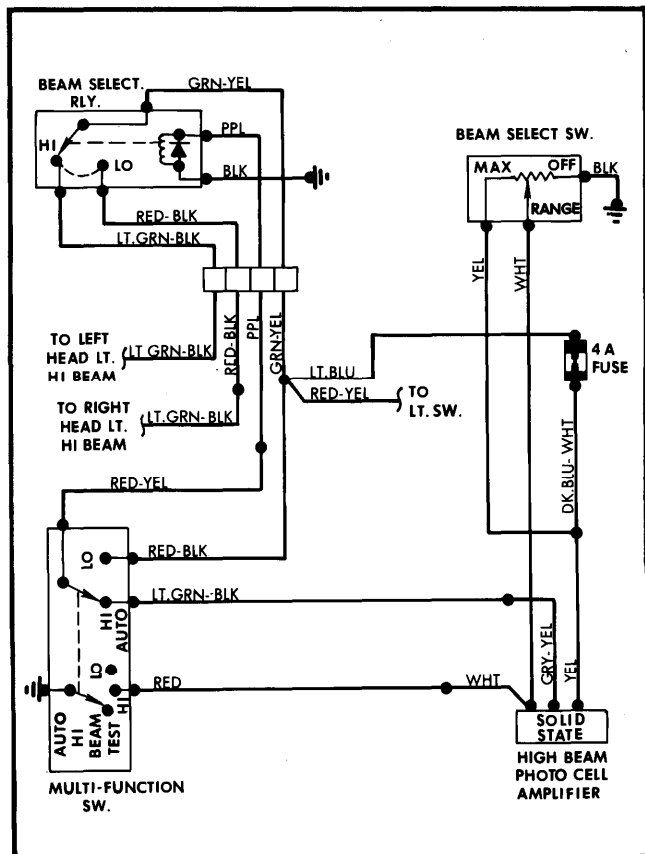

Fig. 2 Headlight Dimmer Wiring Diagram (Lincoln & Mark VI)