

GENERAL MOTORS MOTOR ACTUATED

DESCRIPTION

The electric door lock system uses a permanent magnet motor lock actuator assembly at each door, conventional switches and a relay. All doors lock and unlock manually or from the door control switches. An instrument panel switch is used on station wagons equipped with a tailgate lock only. Buick wagons use a lock relay; all other wagons with tailgate lock only use a polarity-reversing switch system. Camaro and Firebird models also use the polarity-reversing switch rather than a lock relay.

TESTING - RELAY SYSTEM

DOOR LOCKS INOPERATIVE, FUSE BLOWN

Replace fuse, if it blows immediately, check for short in orange wire between fuse and switches. If fuse blows when switch is moved to lock, check blue wire between relay and switches. If fuse blows when switch is moved to unlock, check black wire. If system still does not operate, check for open circuit in orange, blue or black wires.

DOOR LOCKS INOPERATIVE, FUSE GOOD

Check Orange/Black wire at relay for power. If not present, check circuit breaker and feed wire. Place test lamp at Lt. Blue wire and press switch to lock. If lamp goes off, check for open in Orange, Lt. Blue or Black wires. Move lamp to Gray wire and switch to lock. If lamp goes out, check relay ground. Move test lamp to Tan wire and switch to unlock. If lamp goes out, replace relay. If lamp stays on, check for open in Tan or Gray wires.

DOOR LOCKS OPERATE FROM ONE SWITCH ONLY

Check for loose wiring connections. Test Orange wire for power at switch. If no power, check for open in Orange wire. Test Blue wire at switch with switch in lock position. If no power, replace switch. If power is present, check for open circuit in Blue or Black wires.

DOORS WILL UNLOCK BUT WILL NOT LOCK

Check for power at Green/Yellow wire on relay with switch in lock position. If no power, check for open in Blue wire between relay and body harness. If power is present, replace relay.

DOORS WILL LOCK BUT WILL NOT UNLOCK

Check for power at black wire on relay with switch in unlock position. If no power, check for open in black wire between relay and body harness. If power is present, replace relay.

DOOR LOCKS OPERATE EXCEPT FOR ONE DOOR

Check for loose connection or short in circuit. If both leads check to the actuator motor, replace the motor.

DOOR LOCKS INOPERATIVE AND RELAY CLICKS WHEN ACTIVATED

Check Lt. Blue and Black wires between switch and relay.

DOOR LOCKS INOPERATIVE OR LOCKS PULSATE AND RELAY CHATTERS WHEN SWITCH IS ACTIVATED

Gray and Tan wires making contact between relay and lock actuator motor.

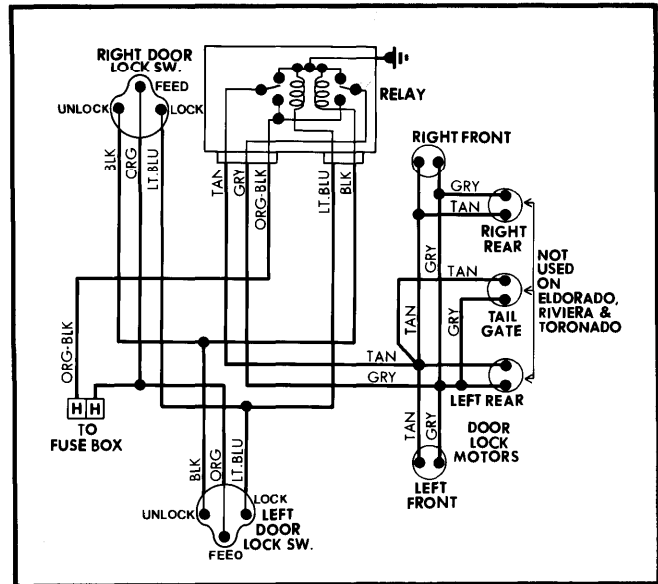

Fig. 1 Relay System Power Door Locks Station Wagon and 4-Door Models (Except Electra, DeVille, Fleetwood, 98)

TESTING - POLARITY SWITCH SYSTEM

DOOR LOCKS INOPERATIVE

Check for power at orange/black wire on switch. If no power, check for open in orange /black wire. If power is present, check ground connection (black/white wire at switch). If ground connection is good, replace driver's door switch.

ONE LOCK INOPERATIVE

Check connections at door lock motor. Check continuity between switch and motor. If wiring is good, replace motor.

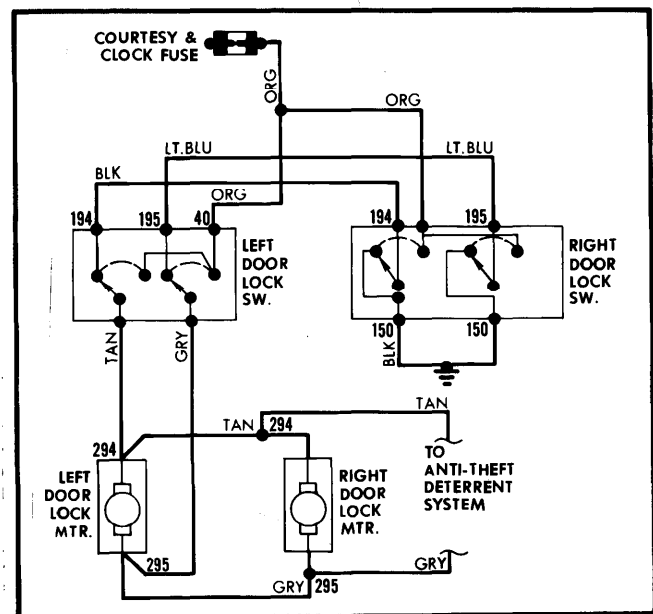

Fig. 2 Corvette Power Door Lock Wiring Diagram

Door & Tailgate Locks

GENERAL MOTORS MOTOR ACTUATED (Cont.)

TAILGATE LOCK INOPERATIVE

Check for power at Orange/Black wire at switch. If no power, check for open or short in Orange/Black, Dk. Grn. or Black wire with switch activated, or check circuit breaker. If power is present, test Dk. Grn. wire with switch in lock position. If no power, check switch ground. If power present, test Black wire with switch in unlock position. If no power, replace switch. If power present, check for open in wiring between switch and tailgate motor. If okay, replace tailgate motor.

TAILGATE LOCK INOPERATIVE OR PULSATES WHEN SWITCH IS ACTIVATED

Check for short between switch and actuator motor.

REMOVAL & INSTALLATION

MOTOR

Removal - 1) Raise window, remove trim pad, detach insulator pad (if equipped), and inner panel water deflector.

2) Punch out actuator attaching rivet center pins, drill out rivets with 1/4" drill bit. Disconnect rod and wire harness and remove actuator through access hole.

Installation - Reverse removal procedures and attach actuator motor to door panel using 1/4"-20 screws and "U" nuts.

RELAY

Removal - Relay is located behind right kick panel or glove compartment. Disconnect wiring and remove mounting bolts to remove relay.

Installation - To install, reverse removal procedure.

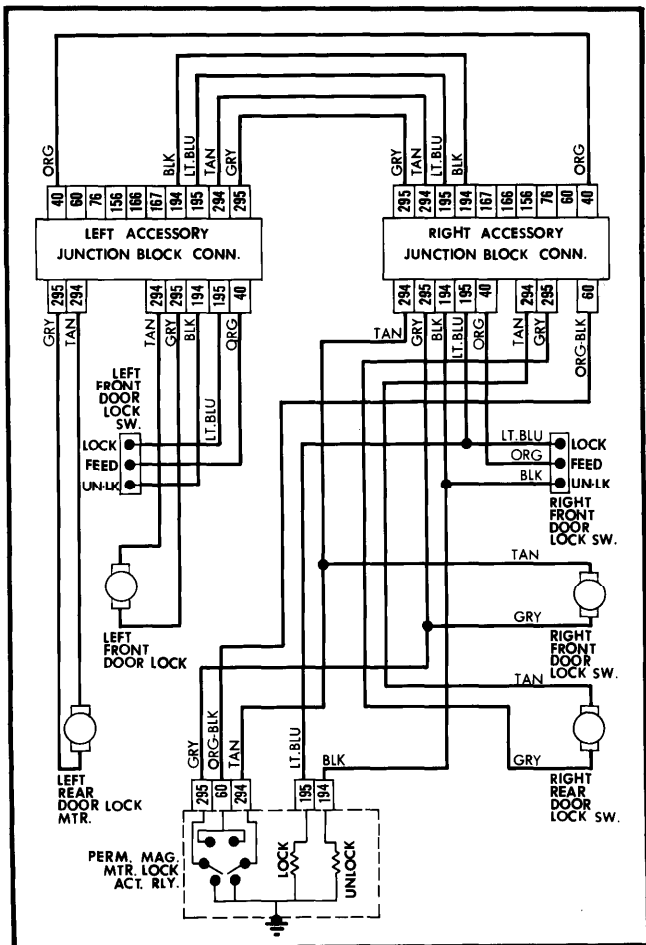

Fig. 3 Polarity Switch System Power Door Locks
Electra, DeVille, Fleetwood and 98
(Riviera, Eldorado, Toronado Similar)

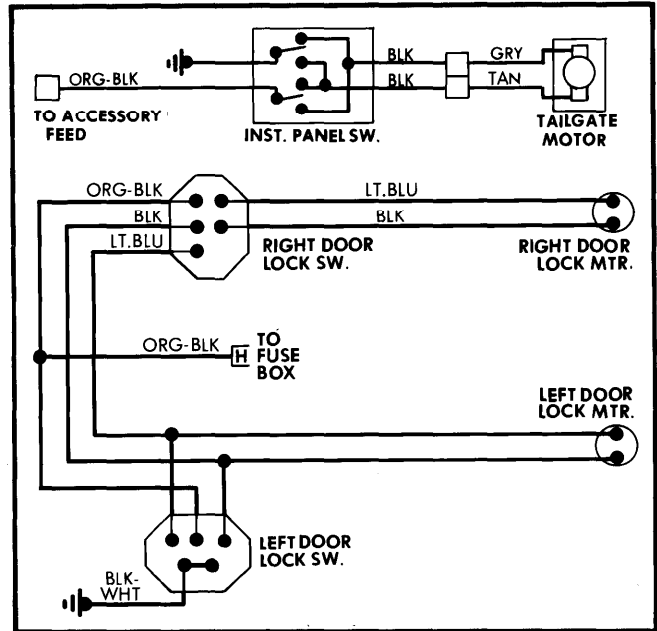

Fig. 4 Polarity Switch System Door Locks
Camaro, Firebird, and Station Wagons

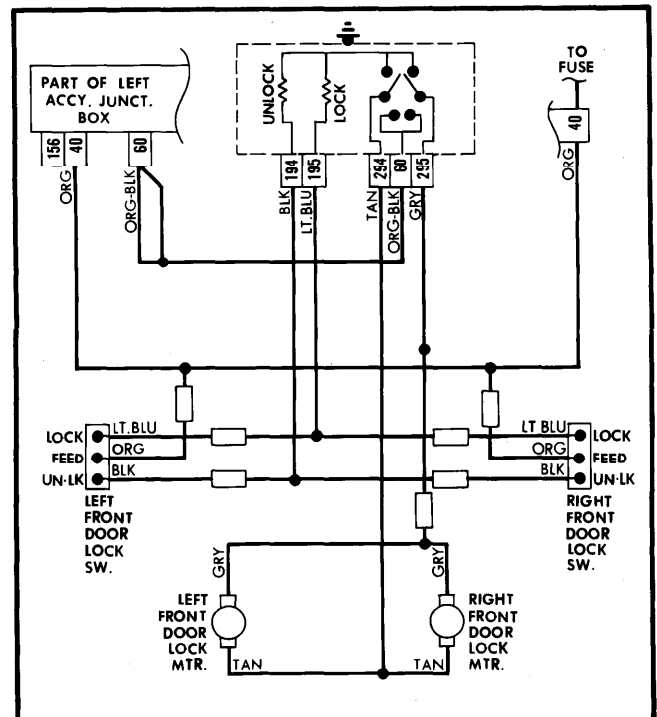

Fig. 5 Polarity System Power Door Locks
2-Door Models Except Riviera,
Eldorado and Toronado