

# Door & Tailgate Locks

## FORD REAR WINDOW AND TRUNK RELEASE

### DESCRIPTION & OPERATION

The rear trunk lid, hatchback, and liftgate releases are electrically operated by a solenoid integral with the latch. A push button is normally located in the glove compartment. The electric tailgate window is operated by a reversible motor and regulator assembly inside the tailgate. A control switch on the instrument panel and a key-operated lock switch operate the power window. A limit switch prevents operation when the tailgate is open.

### TESTING

#### SOLENOID RELEASE

If release does not operate properly, check for power at solenoid connector with ignition and release switch on. If no power, check wiring. If power is present, test for continuity through latch to ground. If ground connection is good, replace solenoid.

#### WINDOW MOTOR

If window does not operate, check fuses. If good, check for correct limit switch adjustment and check ground connection at dashboard switch. If window operates from one switch but not the other, check continuity of both switches in both "UP" and "DOWN" positions.

### REMOVAL & INSTALLATION

#### SOLENOID LATCH

**Removal** — Open trunk or liftgate and disconnect wiring at solenoid. Remove solenoid latch bolts, lock, and latch.

**Installation** — To install, reverse removal procedure.

#### POWER WINDOW REGULATOR AND MOTOR

**Removal** — 1) Remove tailgate glass. Remove glass brackets from regulator arm rollers and equalizer bracket. Disconnect motor wires at connector.

2) Remove 4 regulator attaching rivets and remove regulator. Drill a 5/16" hole through regulator sector gear and plate.

3) Install a 1/4" bolt and nut through hole to prevent sector gear from moving. Remove motor assembly from regulator.

**Installation** — Position regulator and install with rivets or bolts. Connect wiring, replace glass and secure with rivets. Check motor operation.

#### MOTOR (WITHOUT REGULATOR)

**Removal** — Remove tailgate inner panel and watershield and disconnect wires. Remove motor-to-regulator screws and then remove motor and drive.

**Installation** — Position motor and drive, but do not tighten bolts. Connect wiring, cycle motor, and check alignment. Tighten bolts to 50-85 INCH lbs. and replace trim panel.

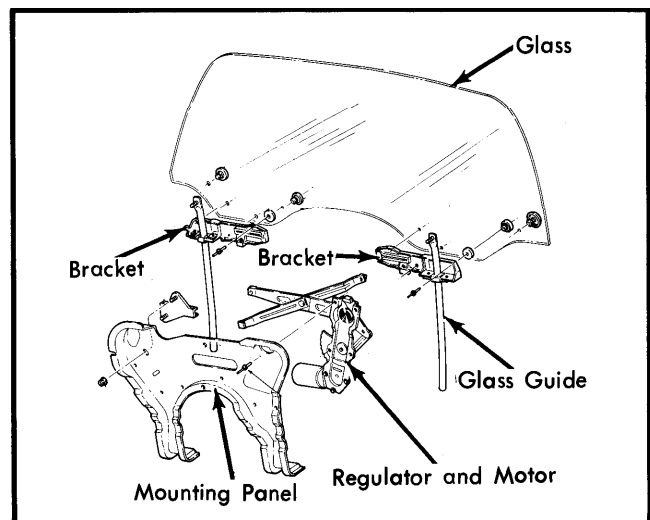

Fig. 2 Identification of Tailgate Components on Ford and Mercury Models

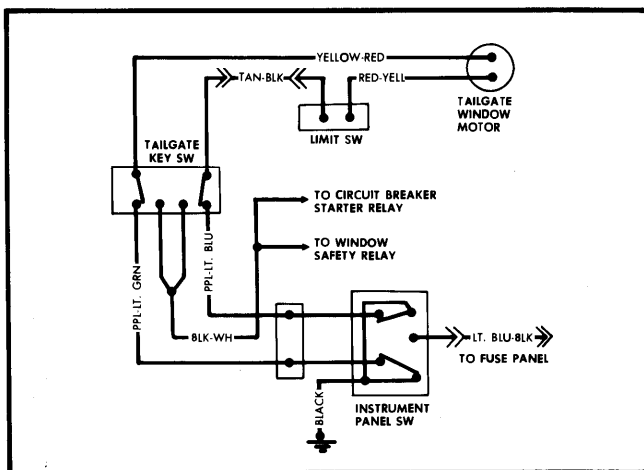

Fig. 1 Ford Motor Co. Power Tailgate Window Wiring Diagram

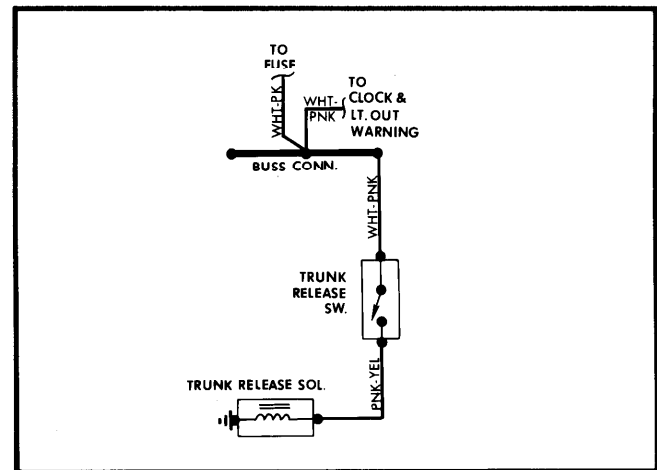

Fig. 3 Ford Trunk Release Wiring Diagram