

Door & Tailgate Locks

AMERICAN MOTORS

All Models

DESCRIPTION

Electric door lock system uses two rocker switches to actuate motors. Either switch locks or unlocks both doors from inside car. Door locks operate with ignition switch in "ON" or "OFF" position. The system is protected by a 30 amp circuit breaker located in the fuse panel.

TESTING

CIRCUIT BREAKER

Disconnect wiring harness connector at fuse panel. Test for power. If no power is present, remove circuit breaker and test for voltage at socket. Test circuit breaker with ohmmeter to check for continuity. If no voltage is present at circuit breaker socket, check fusible link in engine compartment.

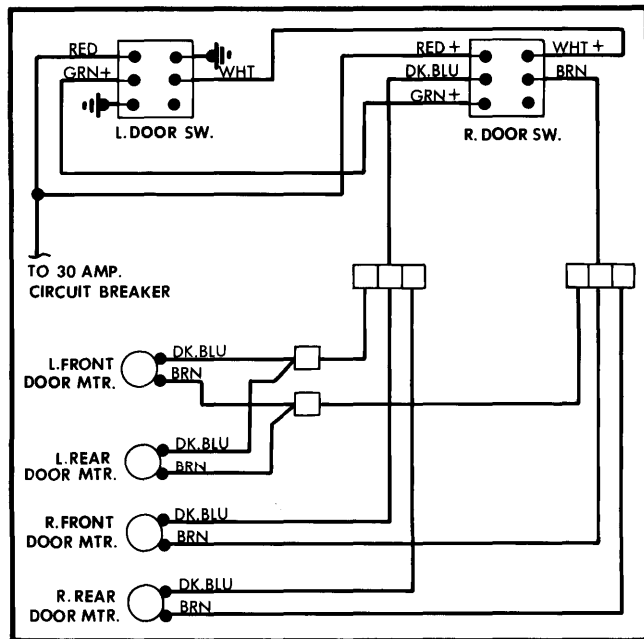

Fig. 1 AMC Door Lock Wiring Diagram

SWITCH TEST

Test door switches for continuity with a self-powered test lamp or ohmmeter. Check connections as indicated in Fig. 2.

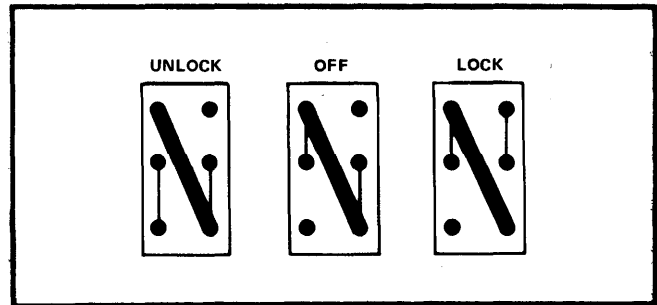

Fig. 2 AMC Door Switch Test Terminals

ACTUATOR MOTOR STALL TEST

Attach an ammeter to motor terminals and operate door switch. Replace motor if current draw is more than 8 amps or if motor does not complete its travel in less than 1 minute.

REMOVAL & INSTALLATION

DOOR LOCK CONTROL SWITCH

Removal - Disconnect negative battery cable. Remove door trim panel. Remove switch housing from inner door panel. Disconnect wiring and remove switch. Pry retainer clips up and remove switch from connector. Depress retainer clips through holes in switch housing and remove switch from housing.

Installation - To install, reverse removal procedure.

NOTE - Hold retainer clips in position on switch and slide switch into housing until they click into position.

ACTUATOR MOTOR

Removal - 1) Disconnect battery cable and remove door trim panel.

2) Disconnect actuator rod from door lock.

3) Using a 1/4" drill bit, remove rivets attaching motor to door panel, disconnect lead wires and remove motor.

Installation - To install, reverse removal procedure, replacing rivets removed with 1/4-20 X 1/2" screws and lock nuts.