

Defoggers — Rear Window

AMERICAN MOTORS WINDOW DEFOGGER GRID

All Models

DESCRIPTION

System components include a heating element grid on the rear window glass, a control switch, pilot light, and relay timer. The current feed to the window grid is through a wire harness attached to the relay timer, located to the side of the brake pedal support. Power feed to the relay is from a battery connection on the fuse panel; power to the control switch is from an ignition connection on the fuse panel.

OPERATION

The defogger can only be operated with the ignition switch "ON". Operating the switch causes the relay contacts to close, supplying power to the grid. A light indicates operation of the defogger. The relay timer keeps the grid heated for 8 to 12 minutes or until the ignition is turned "OFF".

TESTING

SYSTEM TEST

Check for voltage at red wire on fuse panel. If red wire has battery voltage and fuse is good, HOLD switch in "ON" position and check for voltage at white wire on switch and relay. If no voltage, check switch. If voltage is present, test blue wire at relay. If no voltage, clean relay case ground connection. If voltage is present, relay is operating properly and problem is in wiring harness or grid.

CONTROL SWITCH

Control switch can be checked by using an ohmmeter or a test lamp.

Ohmmeter Procedure — With yellow and white wires disconnected from switch, connect ohmmeter across switch terminals. With switch in "OFF" position, ohmmeter should read infinity. With ohmmeter leads reversed, ohmmeter should read zero (or nearly zero). With switch depressed and held in "ON" position, ohmmeter should read zero in both directions.

Test Lamp Procedure — With yellow and white wires disconnected from switch, connect a jumper wire from accessory terminal in fuse panel to one switch terminal. Connect test lamp to other terminal and ground. Observe test lamp, then reverse connections so jumper wire goes to other switch ter-

minal. Test lamp should light in one position, but not both when switch is "OFF". With switch "ON", lamp should light in both directions.

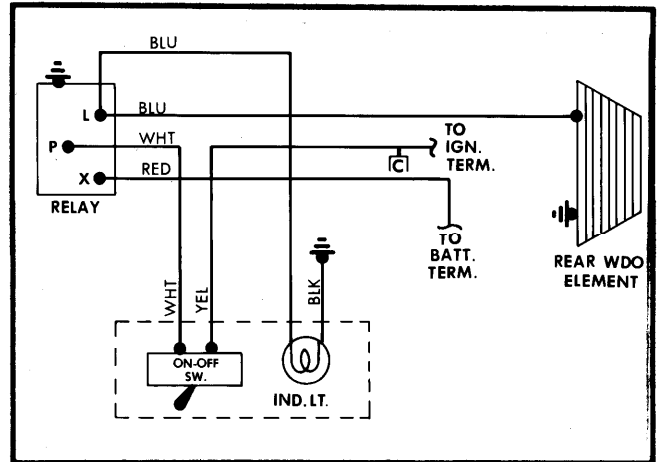

Fig. 1 American Motors Heated Rear Window Wiring Diagram

GRID

Place positive lead of voltmeter on left side of grid and negative lead on right side. Battery voltage should be present with switch and ignition "ON". Test each grid wire, with positive lead in the middle of grid and negative lead on the right side. About 6 volts should be present on each wire. No voltage indicates a broken grid wire. See Fig. 2.

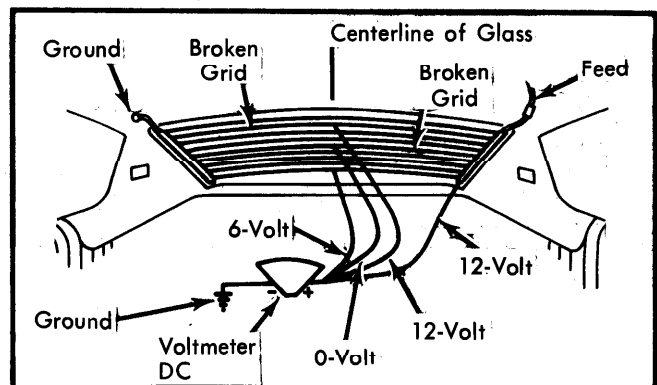

Fig. 2 Voltmeter Check of Rear Window Grid