

# Alternators & Regulators

## CHRYSLER CORP. ALTERNATORS

Chrysler Corp.  
All Except 2.6L Engine

### DESCRIPTION

Chrysler vehicles use either a conventional alternator or the 100 ampere high capacity alternator. The 100 ampere alternator has 12 silicon rectifiers that convert A.C. current into D.C.; the others have only 6 silicon rectifiers. Main components are the rotor, stator, rectifiers, end shields and pulley. The 100 ampere alternator has an external fan, the others an internal fan. Output voltage is limited by an external electronic voltage regulator.

### SPECIFICATIONS

Alternator Part No. (Tag Color)	Volts	①② Rated Amp. Output
4057935 (Yellow) .....	15 .....	60
4091566 (Yellow) .....	15 .....	60
4111266 (Yellow) .....	15 .....	60
5213079 (Yellow) .....	15 .....	60
4111204 (Brown) .....	15 .....	65
5206981 (Red or Yellow) .....	15 .....	65
4091460 (Yellow) .....	13 .....	100

① — At 900 RPM (100 Amp. Alt.); 1250 RPM all others.  
② — Measured at alternator.

**Rotation** — Clockwise at drive end.

**Field Coil Draw** — 4.75-6.0 amps. (100 amp.); 4.5-6.5 amps. (all others); at 12 volts while turning rotor manually.

**Capacitor Capacity** — .50 mfd. ± 20%.

**Current Output** — For 60 amp., 57 minimum; 65 amp., 62 amp. minimum; and 100 amp., 72 amp. minimum.

### ON VEHICLE TESTS

#### CHARGING CIRCUIT RESISTANCE

**NOTE** — Before making test connections, disconnect battery ground cable at battery negative post to avoid accidental shorting of charging or field circuits.

1) Disconnect "BAT" lead at alternator and connect a 0-100 ampere scale D.C. ammeter in series between alternator "BAT" terminal and disconnected "BAT" lead. Connect positive lead of D.C. voltmeter to disconnected "BAT" lead and connect negative voltmeter lead to battery positive terminal. Disconnect green regulator field lead from alternator. Then connect a jumper wire from alternator field terminal to ground. Connect a tachometer and reconnect battery ground cable. Connect a variable carbon pile rheostat to battery terminals. Start engine and operate at idle speed.

**CAUTION** — To avoid damage, reduce speed to idle immediately after starting.

2) Adjust engine speed and carbon pile to maintain 20 amperes flowing in circuit. Voltmeter reading should not exceed 0.7 volts. If a higher voltage drop is indicated, inspect, clean and tighten all connections in charging circuit.

**NOTE** — If necessary, test voltage drop at each connection to locate connection with excessive resistance.

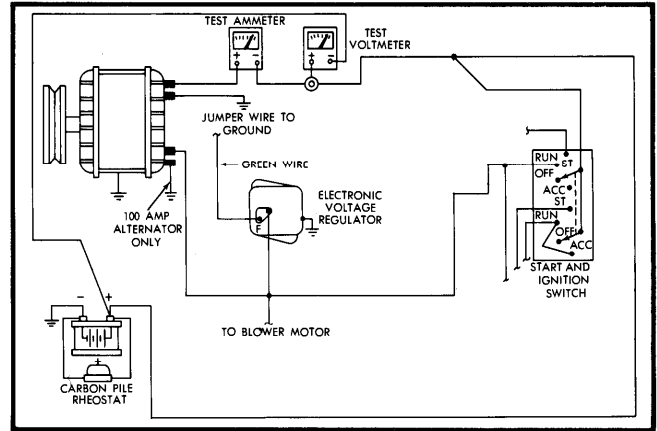

Fig. 1 Diagram Showing Meter Connections for Charging Circuit Resistance Test

#### CURRENT OUTPUT

1) With test connections made as for "Charging Circuit Resistance", move negative lead of voltmeter to a good ground, then move the positive lead of voltmeter to "BAT" terminal of alternator. Start engine and operate at idle.

**CAUTION** — To avoid damage, reduce engine speed to idle immediately after starting.

2) Adjust engine speed and carbon pile until a speed of 900 RPM (100 amp.) or 1250 RPM (all others) and a voltmeter reading of 13 volts (100 amp.) or 15 volts (all others) is obtained.

**CAUTION** — Increase in engine speed should not be large enough to allow voltage to exceed 16 volts.

3) Observe ammeter. Current output should be within specifications. If output is less than specified, remove alternator from vehicle and bench test it.

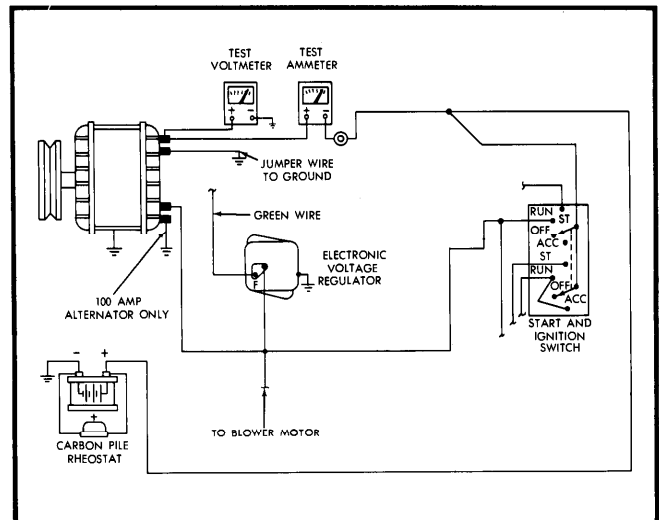

Fig. 2 Diagram Showing Meter Connections for Alternator Current Output Test

## CHRYSLER CORP. ALTERNATORS (Cont.)

### BENCH TESTING

#### FIELD COIL DRAW

1) On 100 ampere alternator, connect a jumper wire between field terminal of alternator and positive terminal of a fully charged battery. Connect test ammeter positive lead to other field terminal of alternator, and the negative lead to battery negative terminal.

2) On other alternators, connect jumper wire between field terminal of alternator and negative terminal of a fully charged battery. Connect test ammeter positive lead to other field terminal of alternator and negative lead to battery positive terminal. Then connect jumper wire between alternator end shield and battery negative terminal.

3) With alternator on an insulated surface, slowly rotate alternator rotor by hand. Observe ammeter reading. Field coil draw should be 4.75-6.0 amps. (100 amp.) or 4.5-6.5 amps. (all others) at 12 volts.

4) A low rotor coil draw indicates high resistance in field coil circuit (brushes, slip rings or rotor coil). A high rotor coil draw indicates possible shorted rotor coil or grounded rotor. No reading indicates an open rotor or defective brushes.

#### RECTIFIER (DIODE) TESTS

**NOTE** — Do not break plastic cases of diodes, cases are for protection against corrosion. Always touch test probe to metal strap nearest diode. Rectifier diodes may be tested with a test lamp or with tester C-3829A as follows:

**Test Lamp Method** — 1) Remove nuts from studs on terminal block securing stator windings and positive and negative rectifier straps.

2) Test rectifiers with a 12 volt battery and test lamp equipped with a No. 67 bulb. Connect one test lamp lead to positive battery post and other lead to test probe. Attach second probe to battery negative terminal. Measure rectifier continuity with probes touching heat sink and rectifier top strap.

3) Now reverse probes. If lamp lights with current flow in one direction only, rectifier is satisfactory. If lamp lights with probes either way, rectifier is shorted. If lamp does not light either way, rectifier is open. Test each rectifier in both assemblies. Replace defective rectifiers. Lamp should light in same direction for all rectifiers of each assembly.

**Tool C-3829A Method (Positive Rectifiers)** — 1) Remove alternator brushes and through bolts. Separate rectifier end shield and stator from drive end shield, pulley and rotor. With alternator on an insulated surface, connect test lead clip to alternator "BAT" output terminal. Plug tool into 110 volt A.C. power supply. Touch test probe to metal strap for each positive rectifier. Reading for satisfactory rectifiers will be  $1\frac{3}{4}$  amperes or more and should be approximately the same for each rectifier. Meter needle should also move in same direction for each rectifier.

2) When 2 rectifiers are good and 1 is shorted, reading taken at good rectifiers will be low and reading at shorted rectifier

will be zero. Disconnect lead to rectifier reading zero and retest. Reading of good rectifiers will now be within satisfactory range. When 1 rectifier is open, it will read approximately 1 ampere, and 2 good rectifiers will read within satisfactory range.

**Tool C-3829A Method (Negative Rectifiers)** — 1) Remove alternator brushes and through bolts. Separate rectifier end shield and stator from drive end shield, pulley and rotor.

2) Connect test lead clip to rectifier end housing. Touch metal strap of each negative rectifier with test probe. Test specifications and results will be approximately the same as for positive rectifiers, except meter will read on opposite side of scale.

**NOTE** — If negative rectifier shows shorted, remove stator from rectifier end shield and retest. Stator winding could be grounded to stator laminations or end shield. This would indicate a shorted negative rectifier.

#### STATOR TEST

**NOTE** — 100 amp. alternator can be checked for stator grounds only. Due to its "Delta" windings, it cannot be checked for opens or shorts with common automotive shop equipment. If stator is not grounded and all other components check correctly, suspect either an open or short in stator.

1) Separate stator from both end shields. Press one test probe firmly against any clean spot (varnish removed) on stator frame. Stator must be bare and clean. Press other probe firmly to each of the 3 phase lead terminals, one at a time.

2) If lamp lights, stator lead is grounded. On all but 100 amp. alternators, press test probe firmly on one phase terminal lead and touch second probe to each of the other 2 stator leads. Test lamp should light when probe contacts each terminal. If lamp does not light, stator is open.

#### ROTOR TEST

1) Test rotor for grounded, open or shorted field coils using an ohmmeter. Test for grounds between slip rings and rotor shaft. No continuity should exist. Check for an open field by connecting ohmmeter across slip rings.

2) Ohmmeter reading should be 1.7-2.1 ohms (100 amp.) or 1.5-2.0 ohms (all others) with rotor at room temperature. Slightly higher readings will be found for rotors that are still warm from operation.

3) Readings above 3.5 ohms indicate high resistance and may require rotor replacement. Readings below 1.7 ohms (100 amp.) or 1.5 ohms (all others) indicate field coil is shorted.

## OVERHAUL

### DISASSEMBLY

1) Remove brush screws, insulating washers, and brush assemblies from end shield.

**CAUTION** — Stator is laminated. Use care not to burr stator or end shield.

# Alternators & Regulators

## CHRYSLER CORP. ALTERNATORS (Cont.)

2) Remove through bolts and pry between stator and drive end with blade of screwdriver (using slot provided on 100 amp.). Carefully separate drive end shield, pulley and rotor assembly from stator and rectifier end shield assembly.

**NOTE** — If negative heat sink diode straps (all but 100 amp.) are on top of positive heat sink straps, loosen 4 hex-head screws on negative rectifier and heat sink assembly. Remove two outer screws and remove heat sink assembly.

3) On all but 100 amp. alternators, remove nut, washer and insulator from "BAT" output terminal on outside of rectifier end shield. Remove round plastic insulator. Turn end shield over and remove nut and washer assembly from end shield stud. Remove capacitor, insulated washer and heat sink assembly. Remove round plastic insulator from "BAT" terminal hole. Remove mica insulator from end shield stud. If negative heat sink diode straps were under positive heat sink diode straps, remove 4 hex-head screws and remove heat sink assembly.

4) On 100 amp. alternators, remove nut and insulator (from inside end shield) securing heat sink assembly to end shield stud. Remove capacitor and insulator. From outside of end shield, remove nut and insulator attaching positive heat sink assembly stud. Remove positive and negative heat sink assemblies, noting location of insulators. Remove terminal block from end shield.

5) On all models, pulley is an interference fit on rotor shaft. Use suitable puller (C-4467 for 100 amp.; C-4068 or C-4333 for all others).

6) On 100 amp. alternators, remove screws attaching bearing retainer to drive end shield. On other models, pry retainer from shield with screwdriver. To separate rotor from end shield, support shield and tap rotor shaft with plastic hammer.

7) Drive end bearing is an interference fit to rotor shaft. Use puller (C-4333 for 100 amp. or C-4068 or C-4333 for all others). Rectifier end shield bearing is a press fit. Use support under end shield when pressing bearing out (C-4330 for 100 amp. or C-3770A and C-3925 for all others).

### SLIP RING REPLACEMENT

Slip rings are not replaced as a separate item. They are replaced with the rotor assembly.

### REASSEMBLY

1) On all but 100 amp. alternators, position grease retainer and press on rotor shaft using suitable installer (C-3921). Retainer is properly positioned when inner bore of tool bottoms on rotor shaft.

2) On all models, position rectifier end shield bearing on base of tool (C-4330 for 100 amp. or C-4201 all others). Place end shield on top of bearing, aligning it properly. Press on top part of tool, until end shield bottoms against base of press.

3) Insert drive end bearing in drive end shield and install bearing retainer plate (on 100 amp. install mounting screws). Position bearing and shield on rotor shaft and while supporting base of rotor shaft, press bearing and end shield into position. Use arbor press and C-3858 tool.

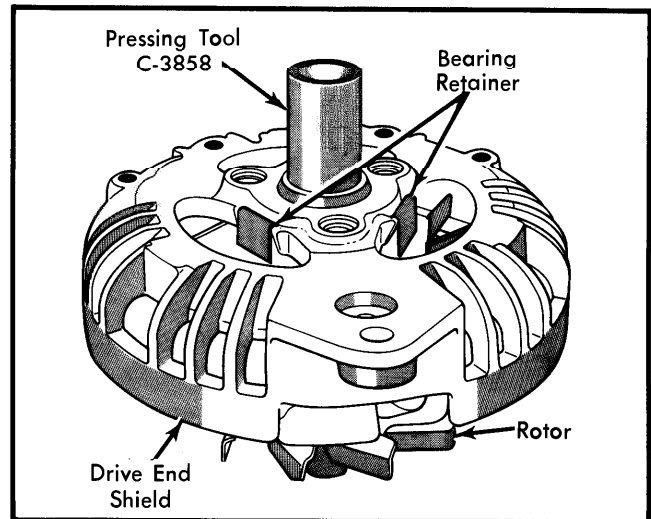

Fig. 3 Installing Drive End Shield Bearing (All Except 100 Amp. Shown)

**CAUTION** — Make sure bearing is installed squarely to prevent damage. Press onto shaft until bearing contacts shoulder on rotor spacer (100 amp.) or rotor shaft fan hub (all others).

4) Install pulley on rotor shaft, supporting shaft so that all pressing is on pulley hub and rotor shaft. Do not hammer.

**All Except 100 Amp. Alternator** — 1) Install mica insulator on heat sink mounting stud in end shield. Install round plastic insulator with flat face up in battery stud hole. Install positive heat sink assembly, guiding 3 diode straps over studs on terminal block.

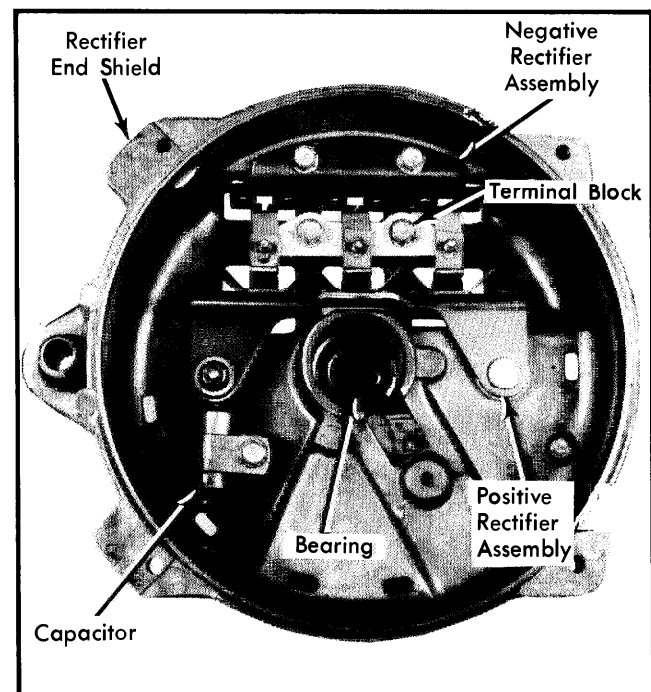

Fig. 4 View of Rectifier End Shield (100 Amp. Shown)

## CHRYSLER CORP. ALTERNATORS (Cont.)

2) Install capacitor terminal, insulator, bracket, and positive heat sink nut and lock washer. Turn end shield over and install round plastic insulator (flat side up), and nut and washer assembly. Slide negative rectifier and heat sink assembly into place in end shield. Position 3 diode straps on terminal block studs. Install hex-head screws. Then follow procedure under *All Models*.

**100 Amp. Alternator** - 1) Position insulator and capacitor on positive heat sink mounting stud. Position terminal block in rectifier end shield. Position negative heat sink assembly into place in end shield, properly positioning metal straps over terminal block studs. Install mounting screws.

2) Install insulator on positive heat sink stud and install assembly into end shield, again making sure metal straps are properly positioned over studs. From inside end shield, install insulator on positive heat sink stud and install mounting nut. From outside end shield, install insulator on positive heat sink stud and tighten nut. Then follow procedure under *All Models*.

**All Models** - 1) Position stator over rectifier end shield and install stator leads on terminal block. Press stator into end shield and tighten winding terminal nuts. Route leads so they cannot contact rotor or sharp edge of negative heat sink.

2) Position rotor and drive end shield assembly over stator and rectifier end shield assembly. Align through bolts, compress assembly and tighten nuts on through bolts (25-55 INCH Lbs. on all but 100 amp.; 40-60 INCH Lbs. on 100 amp.).

3) Install field brushes (100 amp. has long terminal at bottom, short terminal at top; on all others, position vertical and horizontal field brushes in proper location).

4) Rotate pulley slowly by hand to be sure rotor fan blades or rotor poles do not hit stator winding leads. Install alternator and drive belts. Connect alternator "BAT" output lead, 2 field leads and on 100 amp., the ground lead. Reconnect battery ground cable.

5) Start engine and observe alternator operation. Test current output.

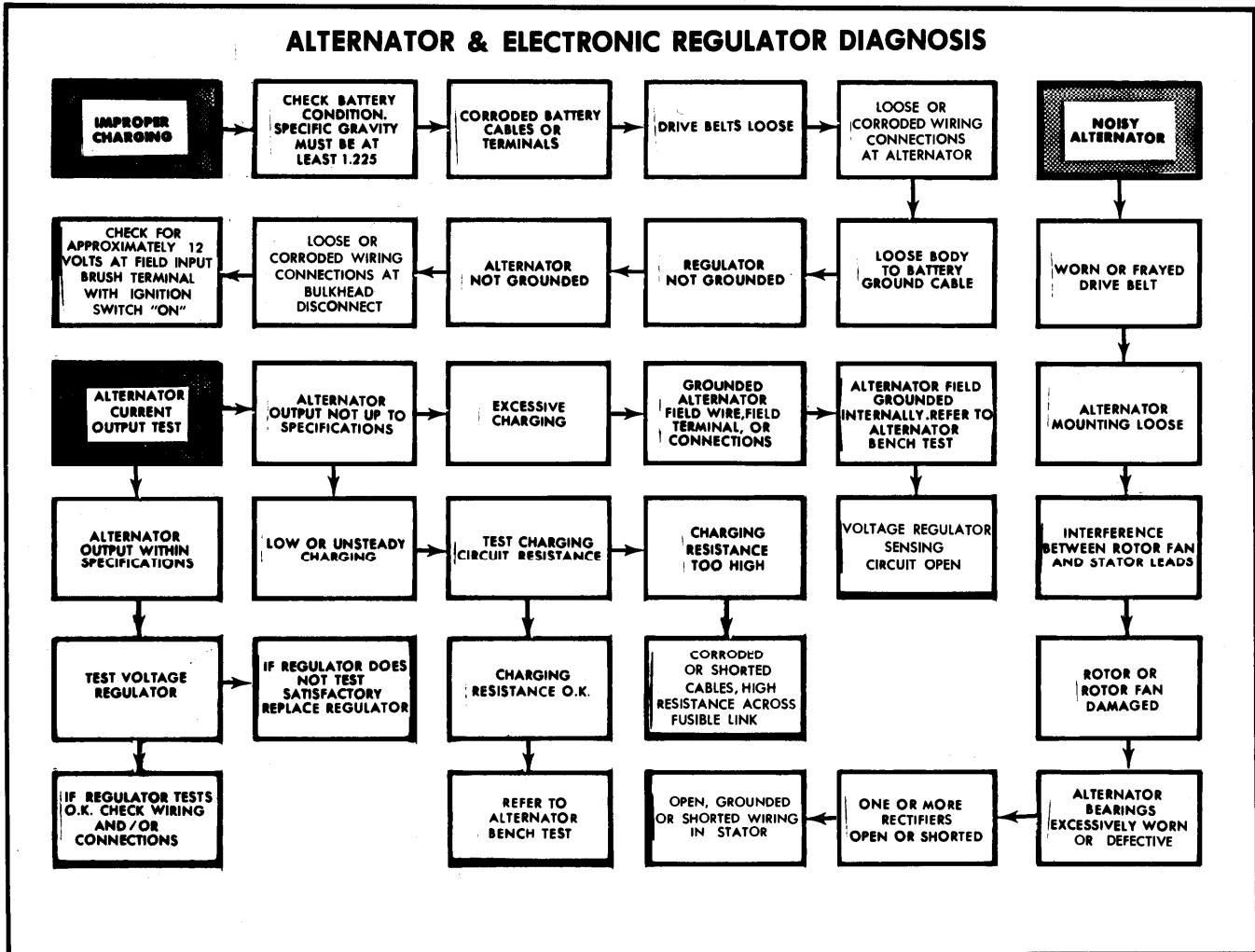

Fig. 5 Charging Circuit Service Diagnosis Guide for All Chrysler Corp. Vehicles

# Alternators & Regulators

## CHRYSLER CORP. ALTERNATORS (Cont.)

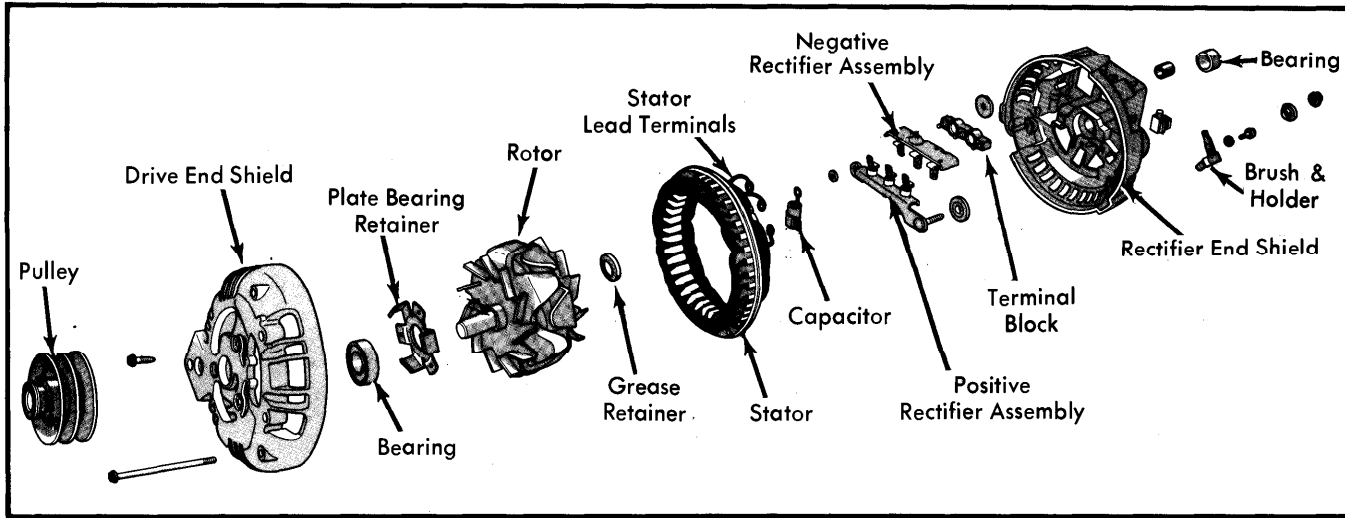

Fig. 6 Exploded View of Chrysler Corp. Alternator (Except 100 Amp.)

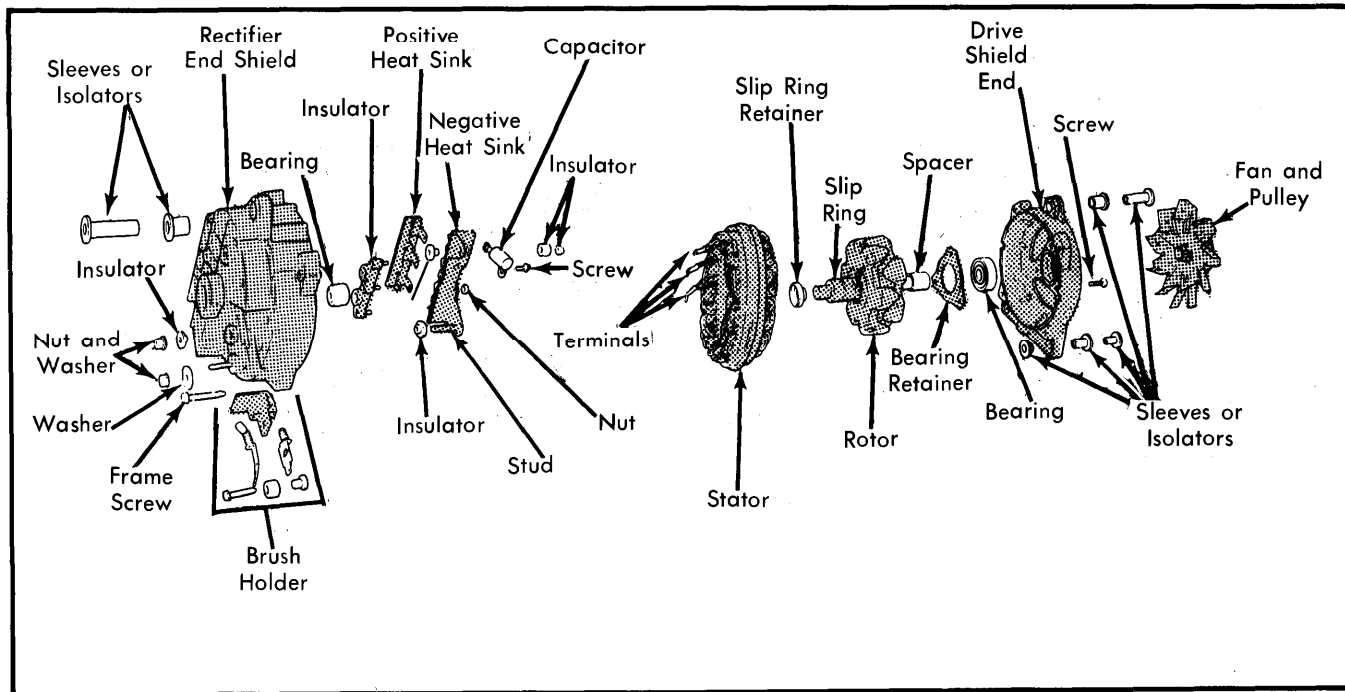

Fig. 7 Exploded View of Chrysler Corp. Alternator (100 Amp.)