

GENERAL MOTORS – INTEGRAL WIPER MOTOR

Buick Skylark
Chevrolet Citation
Pontiac Phoenix
Oldsmobile Omega

DESCRIPTION

The integral wiper motor is used only in General Motors front wheel drive compacts. The wiper motor and gearbox are both housed in a stamped metal cover. An internal circuit breaker protects the motor. Models with the intermittent wiper option use the same motor and have a delay control unit wired between the motor and the switch. The washer pump is powered by a small electric motor and is located in the bottom of the fluid reservoir.

OPERATION

STANDARD WIPERS

Power is applied to the motor when the ignition switch is in the "ON" position. When the wiper switch is moved to the "LOW" position, the low speed brush of the motor is grounded through the switch. When the switch is moved to "HIGH", the high speed brush is grounded. A "MIST" position operates the wipers while the switch is held, and parks the wipers when it is released. An internal park switch keeps the motor operating until it reaches the park position, then disconnects the low speed pole from ground.

INTERMITTENT WIPERS

The integral wiper system has a wiper delay unit, mounted on the dashboard. When the wiper switch is in the "LOW" position, the knob on the delay control determines the interval between sweeps. With the knob at the full counterclockwise position, there is no delay. The "HIGH" and "MIST" positions operate in the same way as the standard system.

WASHER SYSTEM

The washer motor is operated by pushing the "WASH" switch. As long as the switch is held in, the pump is grounded through the wiper switch and will operate.

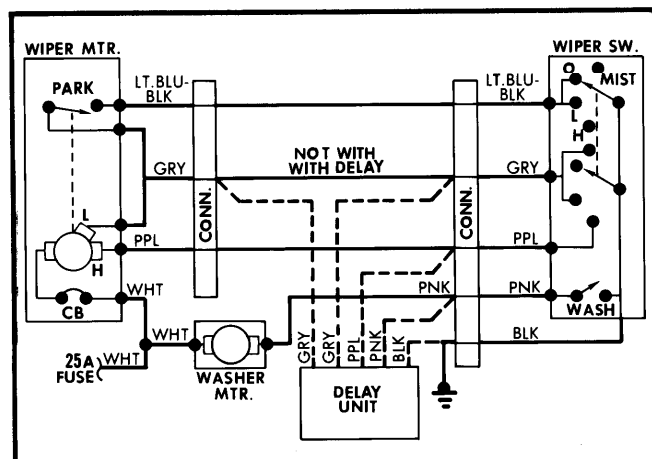

Fig. 1 General Motors Integral Wiper Wiring Diagram
Citation, Omega, Phoenix, Skylark
Standard and Intermittent

TROUBLE SHOOTING

WIPERS DO NOT OPERATE

Check wiper fuse. Ground the Purple and Gray wires one at a time. If wipers operate, check control switch. If not, check motor.

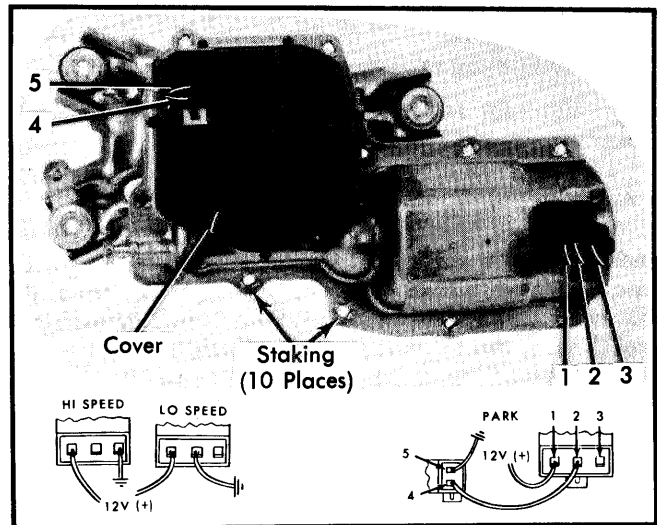

Fig. 2 Integral Motor Wiring Connections

WIPERS DO NOT PARK

Ground the Lt. Blue/Black wire at the motor. If wipers return to park, check switch. If not, check motor.

INTERMITTENT WIPERS OPERATE IN HIGH DO NOT OPERATE IN LOW

Disconnect wiper delay control and connect wiring harness together without delay control. If wipers then operate in "LOW", replace delay control. If not, check motor.

REMOVAL & INSTALLATION

WIPER MOTOR

Removal – 1) Remove wiper arms and blades. Remove lower windshield molding. Tape rear edge of hood to prevent paint damage, and remove cowl panel and screen. Disconnect washer hose.

2) Loosen transmission clamp bolts and detach motor crank arm. Disconnect wiring. Remove 3 motor mounting bolts, hold crank arm with locking pliers, and remove drive nut and crank arm. Rotate motor up and out.

CAUTION – Hold motor crank arm when removing or installing drive nut to prevent stripping nylon drive gear.

Installation – To install, position motor, hold crank arm with locking pliers and tighten drive nut. To complete installation, reverse removal procedure.

Wiper/Washer Systems

GENERAL MOTORS – INTEGRAL WIPER MOTOR (Cont.)

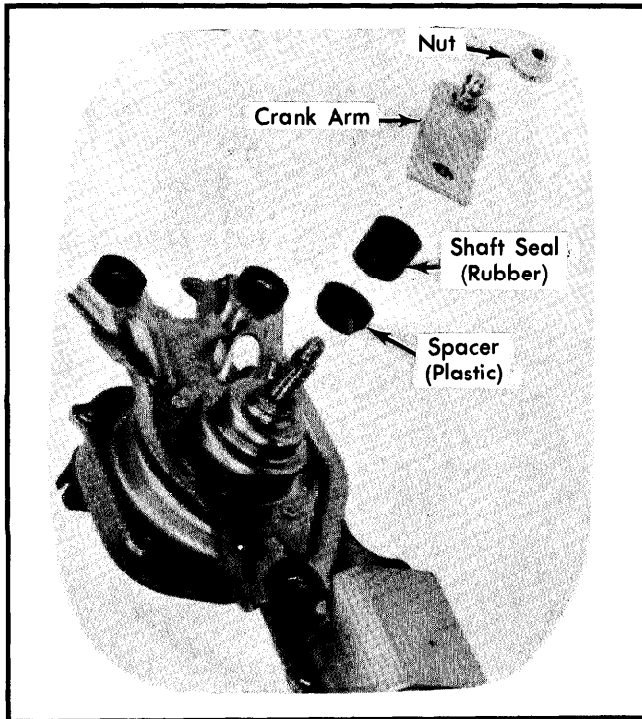

Fig. 3 Integral Motor Crank Arm Assembly

WIPER SWITCH

Removal – 1) Remove steering wheel, turn signal switch, ignition lock and key buzzer. Remove steering column cover screws and lift cover off.

NOTE – For complete procedures, see *Steering Column Switches* in *STEERING* Section.

2) Remove retainer, pivot pin, and wiper switch from column.

Installation – To install, reverse removal procedure.

DELAY CONTROL SWITCH

Removal – Disconnect battery cable. Remove trim plate or cluster bezel for access to switch. Remove mounting screws or ferrule nut and pull switch forward. Cut 5-wire harness at switch and remove switch. Disconnect other end of harness under steering column and cut off connector if harness tape is wrapped around delay control wiring.

Installation – Feed new harness through switch opening and connect under steering column. Replace switch, install screws or ferrule nut, and install trim plate or bezel. Reconnect battery.