

Power Windows

AMERICAN MOTORS

DESCRIPTION

Window motors are of a two wire design, using polarity of circuit to change motor rotation. Windows are controlled by an individual switch mounted in each door trim panel. A master switch is located on drivers side. The ignition switch must be in the "ON" position to operate windows. A 30 amp. circuit breaker, mounted in back of instrument panel on far left side, protects circuit.

TROUBLE SHOOTING

WINDOWS FAIL OR OPERATE SLOWLY

Battery low or dead, circuit breaker faulty, battery ground loose, terminal in control circuit loose or corroded.

WINDOWS OPERATE INTERMITTENTLY

Loose wires on circuit breaker or switches, or circuit breaker faulty.

ONE WINDOW FAILS TO OPERATE

Loose or broken connections at circuit breaker, faulty switch, defective window motor.

TESTING

VOLTAGE TEST

Remove switch from door and disconnect plug. Turn ignition "ON" and connect test lamp between red (with tracer) wire and ground. Lamp should light; if not, check circuit breaker and power feed wire. Move test lamp ground lead to black ground wire in switch connector. If lamp does not light, check ground connection.

SWITCH TEST

- 1) Connect a jumper wire between Red wire and Yellow or Violet wire at switch connector. Connect a second jumper between Black wire and Orange or Dark Green wire. Motor should move window either up or down.
- 2) Reverse jumper wire connections. Motor should move window in opposite direction from first test. See Fig. 1.
- 3) If motor operates properly, reconnect switch and test for correct operation. If not, replace switch. If motor did not operate properly, test window motor. Test all switches and motors.

MOTOR TEST

Connect jumper wires directly from battery to motor terminals. Motor should operate in one direction. Reverse battery leads and retest; motor should run in opposite direction. If motor does not operate properly, remove and bench test. If motor operates on bench, repair window tracks or regulators. If not, replace motor.

REMOVAL & INSTALLATION

MOTOR

Removal — Disconnect battery ground cable and remove door trim panel. Drill out 2 rivets retaining motor to door. Disconnect wiring and remove motor.

Installation — Connect motor wiring. Install motor in door using 1/4-20 bolts and nuts. Install door panel and reconnect battery ground cable.

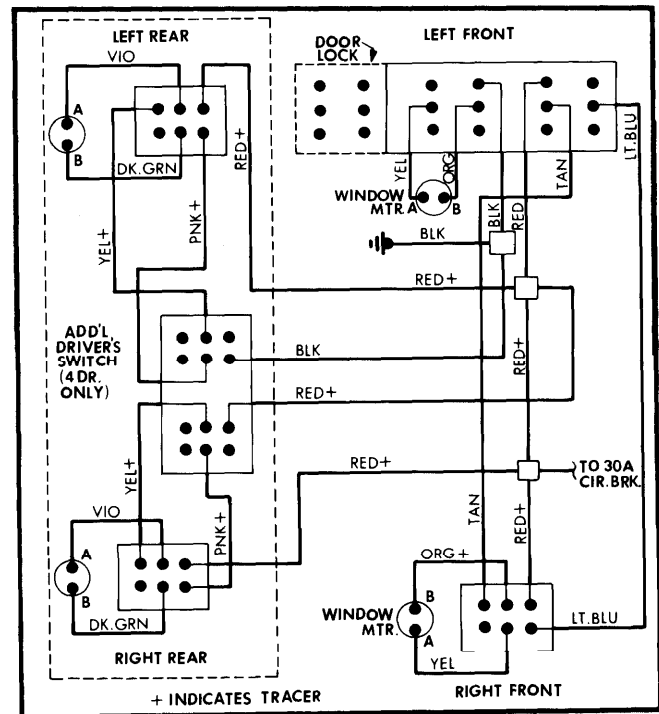

Fig. 1 Power Window Wiring Diagram
American Motors