

CHRYSLER CORP.

All Models

DESCRIPTION

The power seat system consists of a three armature, reversible motor, a control switch assembly, and wiring harness. The circuit is fed by a 30 amp circuit breaker located in the fuse panel.

OPERATION

The front control switch powers the front edge of the seat up and down. The rear switch does the same for the rear edge of the seat. The center switch raises and lowers the entire seat and controls forward and rearward movement.

TROUBLE SHOOTING

If power seat malfunctions, test for electrical or mechanical failure. With wiring connected and dome light on, operate switches. Watch ammeter or dome light for evidence of power consumption by seat motors. If dome light dims and ammeter moves, motor is jammed and a mechanical problem is indicated. If no evidence of power use, wiring and electrical problems are indicated.

TESTING

CIRCUIT BREAKER

With test lamp, check for voltage at power feed terminal and at circuit breaker output side. If power is present, circuit breaker is okay.

WIRING HARNESS

Disconnect wire harness connector under seat. Check for power between RED and BLK wires in female connector. If power is present, wiring to seat is good.

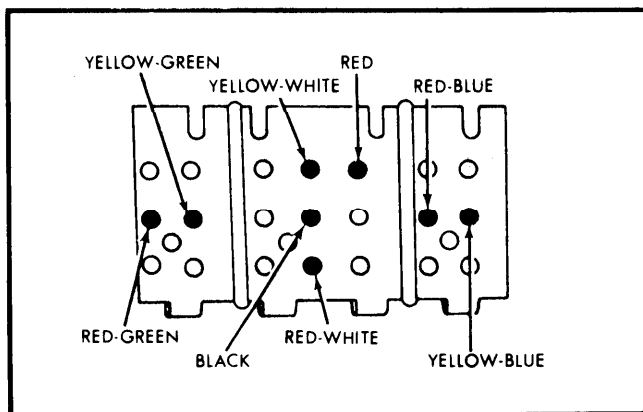

Fig. 1 Master Switch Connector Test Points

FRONT MOTOR

Connect a jumper lead between RED wire terminal in center section of connector and either the RED-GRN or YEL-GRN connection in front section (See Fig. 1). Connect another jumper wire between BLK wire terminal in center section and open con-

nection in front section. If motor does not operate, reverse jumpers in front section. If motor still does not operate, either harness or complete three motor assembly should be replaced.

CENTER MOTOR

Connect a jumper lead between RED wire terminal of center section of connector and either the RED-WHT or YEL-WHT terminal of center section. Connect another jumper between BLK terminal and open terminal in center section (See Fig. 1). If motor does not operate, reverse RED-WHT and YEL-WHT jumper connections. If motor still does not operate, either harness or three motor assembly should be replaced.

REAR MOTOR

Connect a jumper lead between RED wire terminal in center section of connector and either the RED-BLU or YEL-BLU terminal in rear connector section. Connect another jumper between the BLK wire terminal in center section and open connection in rear section. If motor does not operate, reverse jumpers in rear section. If motor still does not operate, either harness or three motor assembly should be replaced.

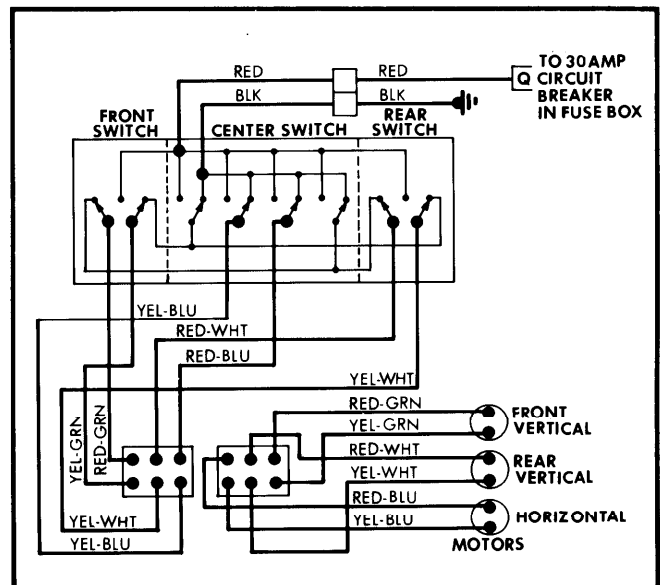

Fig. 2 Chrysler Power Seat Wiring Diagram

CONTROL SWITCH

If motors and seat operate properly when switch is by-passed during electrical tests, the switch is defective and should be replaced.

REMOVAL & INSTALLATION

MOTOR

Removal — Disconnect battery ground cable. Raise vehicle and remove mounting nuts holding seat assembly to floor pan. Disconnect wiring harness and remove seat assembly from vehicle. Remove bolt securing motor to support. Remove motor

CHRYSLER CORP. (Cont.)

mounting screws (see Fig. 3). Disconnect housings and cables from motor assembly and remove motor.

Installation — Position motor onto support of seat assembly. Connect housings and cables to motor. Install and tighten motor mounting screws, and repeat this for bolt securing motor to support. Position seat assembly in vehicle and attach wiring harness. From underneath vehicle install and tighten floor pan mounting nuts to seat.

CABLE & HOUSING

Removal — Remove motor assembly from seat. Disconnect cable from motor, then remove clamp from cable housing. Slide cable and housing out of connector. Check cable for kinks and wear.

Installation — Insert cable and housing into connector. Synchronize motor and transmission. Install motor assembly and seat assembly in vehicle.

TRANSMISSION

Transmissions are not removable and no maintenance is required. If transmission fails replace entire seat adjuster assembly.

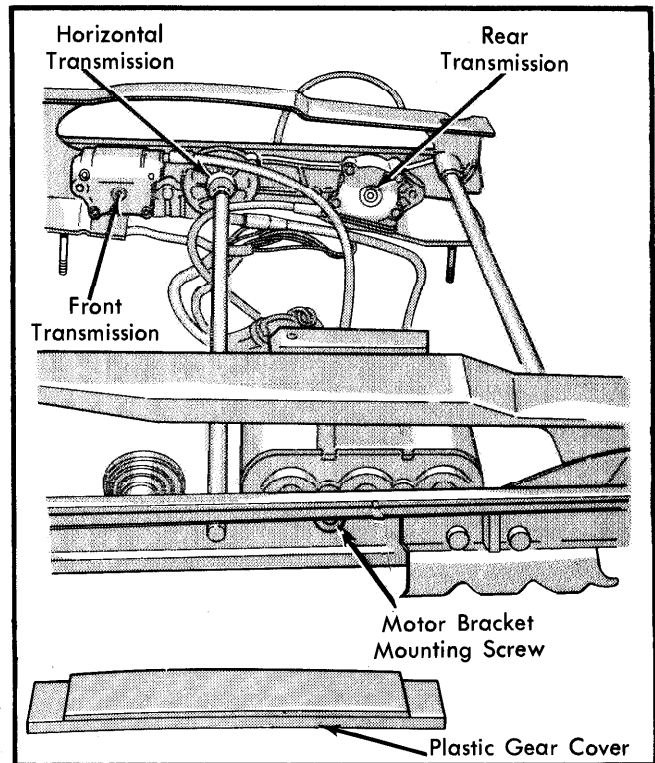

Fig. 3 Chrysler Seat Track Identification