

# Headlight Doors — Automatic

FORD MOTOR CO.

Mark VI  
Thunderbird

## DESCRIPTION

Headlight covers are actuated by two vacuum motors on all models. Vacuum is directed to motors by a vacuum distributor valve integral with headlight switch. A reserve vacuum reservoir provides limited headlight cover cycling without engine running. A check valve is used in vacuum source line to prevent vacuum leakage back to engine. Springs and a by-pass valve permit manual operation of the doors if vacuum system fails. Models with Autolamp feature have a solenoid valve which controls vacuum to the door motors.

## OPERATION

Pulling out headlight switch knob actuates the distribution valve on back of switch. Vacuum is then applied to vacuum motors, opening headlight covers. Distribution valve also provides a vacuum relief (exhaust) port to side of motor diaphragm without vacuum. When headlight switch is pushed in, vacuum supply and relief ports are reversed and headlight covers close. The reserve vacuum reservoir provides vacuum storage for limited headlight cover cycling. A reservoir check valve is used to prevent vacuum leakage back to engine and is located in vacuum supply line.

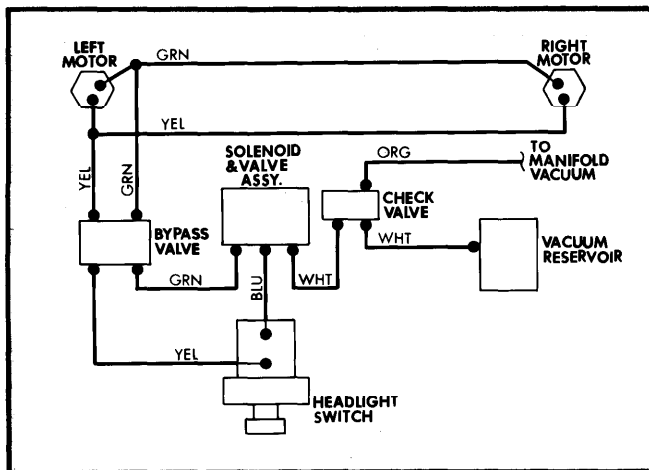

Fig. 1 Ford Motor Co. Headlight Door Vacuum Hose Diagram (Autolamp System Shown)

Headlight covers on all models have springs built into each motor. Vacuum applied to vacuum motors during closing overcomes spring tension. A by-pass valve is located in vacuum lines between headlight switch and vacuum motors. By-pass valve vents system to allow covers to open if they will not open automatically.

**NOTE** — If engine has been shut down long enough to allow a normal leakdown in vacuum system (18 hours), springs will open headlight covers.

## TESTING

Use a vacuum gauge to test system for leaks. Vacuum should not drop when headlight switch is moved through the "OFF-PARK-ON" positions. If doors do not open, turn on lights and turn by-pass valve to vent position. If doors open, check hoses between switch and by-pass valve. If doors do not open with valve in vent position, check doors for binding and check vacuum lines between valve and doors. Replace kinked or damaged hoses, and any leaking components.

## REMOVAL & INSTALLATION

### VACUUM MOTOR

Disconnect vacuum hoses from cover motor. Disconnect clip retaining motor control rod to headlight cover outer shaft assembly and remove rod from shaft. Remove nuts retaining motor assembly to motor support and remove motor through opening at bottom of vehicle. To install, reverse removal procedure, noting that hose with green stripe goes to top of motor and hose with yellow stripe on bottom.

### VACUUM RESERVOIR

Raise left front of vehicle and remove left front tire and wheel assembly. From under fender, remove retaining nuts from vacuum reservoir, remove vacuum hoses and remove vacuum reservoir. To install, reverse removal procedure.