

# Headlights — Automatic

## FORD MOTOR CO. AUTOLAMP

Thunderbird, Cougar XR-7  
Ford, Mercury  
Continental, Mark VI

### DESCRIPTION

Autolamp system provides light sensitive automatic on-off control of headlights in conjunction with normal headlight switch operation. A light delay feature is also used to keep headlights on for a preselected time period after ignition is turned off and occupant has left vehicle. Time lapse can be varied up to 4½ minutes before lights turn off automatically. Autolamp system consists of a light sensitive photocell assembly, transistorized amplifier, and time delay control which includes an on-off switch.

### OPERATION

Autolamp wiring parallels the regular light switch wiring, and headlight switch must be turned "OFF", and autolamp control turned "ON" for system to operate automatically. Autolamp control switch is located behind headlight switch knob. In normal operation, system will turn headlights on when natural outside light available to photocell decreases below a predetermined level, such as at sunset. Also, lights will automatically turn off if level of outside light exceeds a predetermined level during daylight hours. System photocell is mounted under a group of perforated holes in upper instrument finish panel on left side. Turning the autolamp control away from "OFF" position will increase lapsed time before headlights turn off after turning ignition switch off. If vehicle is equipped with headlight covers, system will synchronize and control cover opening and closing.

### TESTING

#### SYSTEM OPERATIONAL CHECK

**NOTE** — When a system malfunction is unknown, perform following checkout procedure to isolate problem to a specific condition.

- 1) Check possibility that control unit may be turned "OFF", photocell may be covered or unit is being operated with regular light switch turned "ON".
- 2) Cover photocell and turn ignition "ON". With autolamp control "ON", headlights should come on within 10 seconds. Uncover photocell and lights should turn off.
- 3) Cover photocell and allow time for lights to turn on. Now turn ignition "OFF", lights should remain on for 1½ to 4½ minutes, depending on control setting, and then turn off.

#### CIRCUIT TESTS

**Quick Check** — Turn Autolamp control off and headlight switch on. If headlights fail to come on, check headlight circuits. If lights come on, check Autolamp fuse. If fuse is good, check "Sensor Amplifier Adjustment". If fuse and adjustment are good, proceed with tests.

**NOTE** — Refer to illustrations for connector and terminal identification.

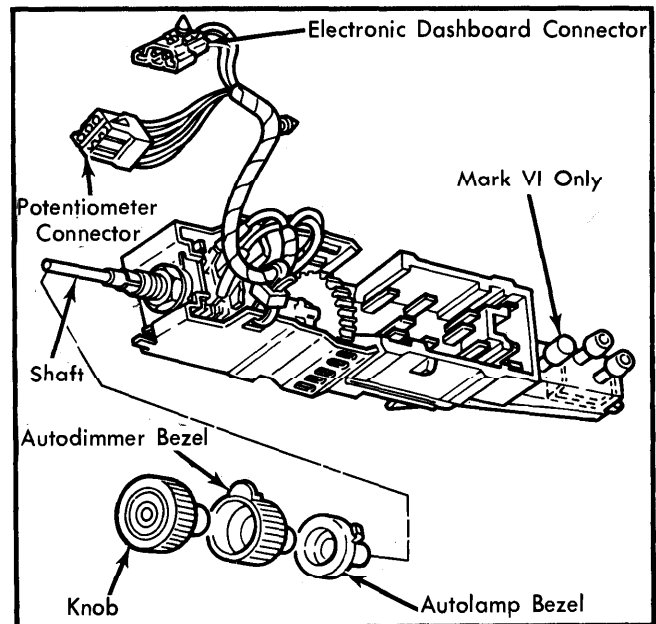

Fig. 1 Autolamp Headlight Switch Assembly  
Continental & Mark VI

**Tail Light Circuit** — Remove connector from autolamp relay. Connect a test lamp between ground and brown wire. Voltage should be present with headlight switch in "PARK" or "ON" position. If not, check continuity of wire to headlight switch.

**Headlight Circuit** — Remove connector at autolamp relay. Connect a test lamp between ground and the red/yellow wire. Voltage should be present with switch in the "ON" position. If not, check continuity to headlight switch, and if equipped, to headlight cover solenoid valve and hi-lo beam relay.

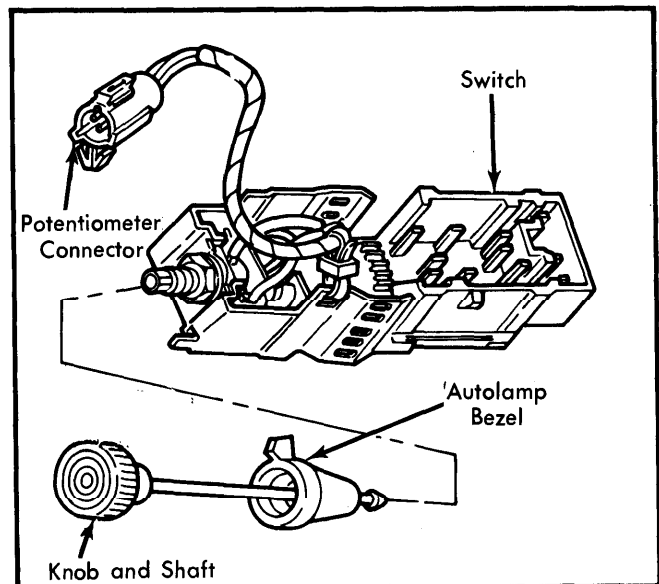

Fig. 2 Autolamp Headlight Switch Assembly  
Ford, Mercury, Cougar XR-7 (Thunderbird Similar)

## FORD MOTOR CO. AUTOLAMP (Cont.)

**Autolamp Control Switch (Continental, Mark VI)** – Using ohmmeter or powered test lamp, check continuity from potentiometer connector terminal 5 to ground at switch bracket. Also check continuity from terminals 5 to 2 while turning switch from "OFF" to "ON". Test resistance from terminals 1 to 5 while turning control from "OFF" to "MAX". Resistance should vary from 2.5-4.5K ohms to 140-260K ohms.

**Autolamp Control Switch (Except Continental, Mark VI)** – Check for continuity from potentiometer connector black wire to ground at switch bracket. Also, check for continuity between black and purple/orange wires with switch "ON". Test resistance between black and dark blue/orange wires while turning control from "OFF" to "MAX". Resistance should vary from 2.5-4.5K ohms to 140-260K ohms.

**NOTE** – If any part of the control switch test is unsatisfactory, replace potentiometer.

**System Ground** – Check for continuity between ground and sensor amplifier connector terminal 3. With switch "ON" there should be continuity to ground. If not, check condition of purple/orange wire.

**NOTE** – If the preceding tests checked out good and the Autolamp system still has a malfunction, replace sensor amplifier and photocell as an assembly.

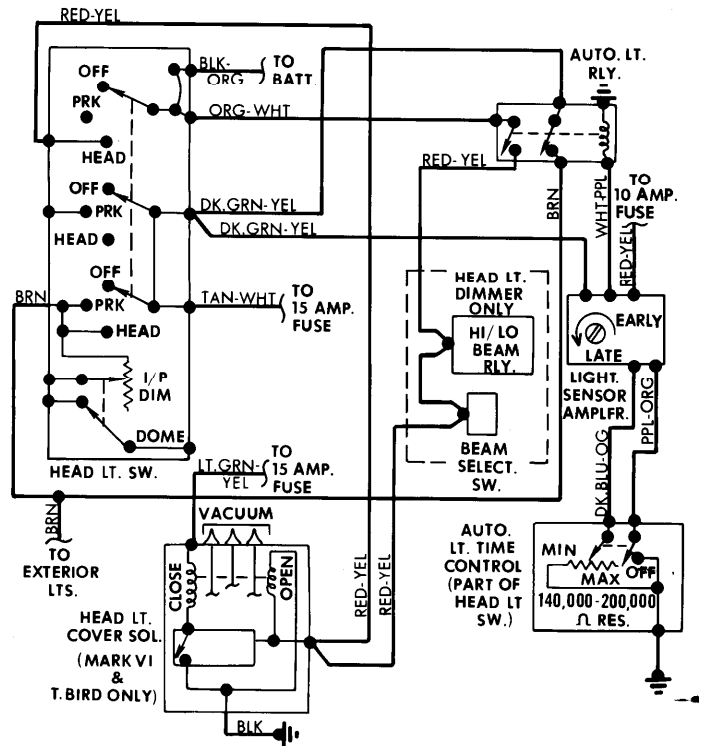

Fig. 4 Autolamp Wiring Diagram (All Models)

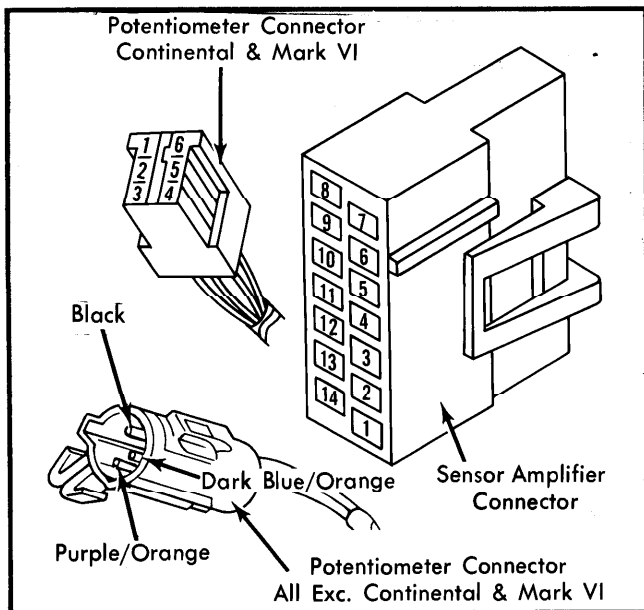

Fig. 3 Autolamp Circuit Connectors Terminal Identification

### ADJUSTMENT

#### SENSOR AMPLIFIER

There are two different amplifiers utilized. Both amplifiers have a label attached to the case providing adjustment instructions.

### REMOVAL & INSTALLATION

#### HEADLIGHT CONTROL RELAY

Disconnect battery ground cable. Remove screws holding relay bracket below dash, then remove screw holding relay to bracket. Remove connector. To install, reverse removal procedure.

#### SENSOR AMPLIFIER

Remove instrument panel top pad by removing screws at either end and below front edge. Lift off top pad and remove 2 screws holding sensor amplifier to instrument panel. Remove connector. Reverse removal procedure to install sensor amplifier.

#### HEADLIGHT SWITCH & POTENTIOMETER

**NOTE** – Either headlight switch or potentiometer can be replaced separately. Both units must be removed as an assembly.

Disconnect battery ground cable. Remove headlight knob, bezels, and switch. See *Switches, Gauges, and Instrument Panels in this Section*. Remove the plastic spacer at the end of the potentiometer by pushing out with a screwdriver. Loosen retaining nut and washer and slide potentiometer out of switch. To install, reverse removal procedure.