

# Door & Tailgate Locks

## GENERAL MOTORS AUTOMATIC – BUICK & CADILLAC

**Buick (Electra, Riviera)**  
**Cadillac (All Models)**

**NOTE** — Also refer to General Motors Motor Actuated Door Locks in this section.

### DESCRIPTION

The automatic door lock system uses the conventional power door lock system, but to accomplish the automatic feature the following additional components are used: Electronic logic module, two unlock relays, a lock relay, the back-up light switch, right and left front door lock remote control handle switches, and a drivers position seat sensor (Cadillac). Buick uses a left front door lock cylinder key switch.

The module is located behind the glove box on Eldorado and Riviera, and behind the right kick panel on all other models. Lock and unlock relays are taped to the module except the Cadillac lock relay which is located behind the left kick panel. All switches and relays are replaced as an assembly. The module consists of 2 components: the wiring harness/case and the printed circuit board.

### OPERATION

**Cadillac** — Doors lock automatically when all doors are closed, courtesy lamps are off, the driver is seated, and transmission is shifted into "D". If a passenger unlocks the door and exits while the shifter is in "D", all doors will automatically lock when the door is closed. When the shift lever is moved to "P", the driver's door will unlock.

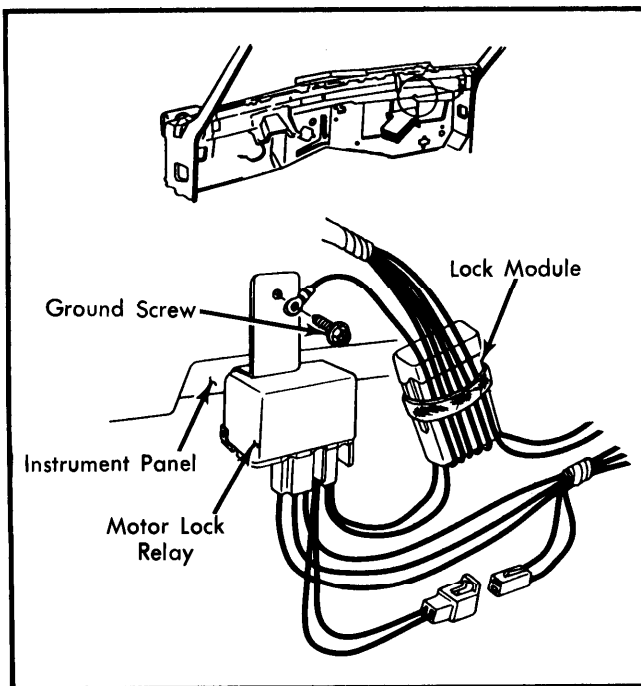

**Fig. 1** Module and Motor Lock Relay  
Eldorado and Riviera Shown

**Buick** — Doors lock automatically when all doors are closed, courtesy lamps are off, and the transmission is shifted into "D". When the shift lever is moved to "P", all doors unlock. All doors also unlock when the driver's door is opened from outside with a key.

### TROUBLE SHOOTING

#### AUTOMATIC LOCKS INOPERATIVE LOCKS OPERATE FROM DOOR SWITCHES

- 1) Test with driver's seat occupied (Cadillac), ignition on, all doors closed, and transmission in "D". Ground one end of a self-powered test lamp and touch probe to Black wire on module. If lamp does not light, repair Black wire or ground connection.
- 2) Ground one end of a non-powered test lamp and check for power at the Pink/Black wire on module. If no power, repair wire.
- 3) If power is present on Cadillac models, replace module circuit board. On Buick models, check for power at the Lt. Blue/Black wire. If no power, repair wire. If power is present, replace circuit board module.

#### DOORS UNLOCK AUTOMATICALLY DO NOT LOCK AUTOMATICALLY

- Eldorado and Seville** — 1) Test with driver's seat occupied, ignition on, all doors closed, and transmission in "D". Ground one end of a test lamp and check Black/White wire at lock relay. If no power, check wire and drive switch on column.
- 2) If power is present, move test lamp to Lt. Green wire on lock relay. Move shifter from "D" to "P", then back to "D". If lamp does not light, touch test lamp to Black wire. If relay clicks, repair Black wire to ground connection. If no click from relay, replace relay.
  - 3) If lamp came on when shifter was moved, check continuity of Lt. Green wire between relay and module. Touch test lamp to Yellow wire on module, and move shifter to "P" and back to "D".

- 4) If lamp does not light, replace printed circuit board in module. If lamp lights, move probe to Lt. Blue wire on motor lock relay. If no power, check seat sensor and wiring between module and motor lock relay.

**DeVilve and Fleetwood** — 1) Test with ignition on, all doors closed, driver's seat occupied, and transmission in "D". Touch test lamp to Black/White wire on module. If doors lock, repair wire or drive switch.

- 2) If doors do not lock, test at Yellow wire on module. Move shift lever to "P" and back to "D". If lamp does not come on, replace module circuit board.

- 3) If lamp lit at Yellow wire, move probe to Lt. Blue wire on motor lock relay. If lamp is on, system is okay. If lamp does not light, check seat sensor and wiring between module and motor lock relay.

## GENERAL MOTORS AUTOMATIC – BUICK & CADILLAC (Cont.)

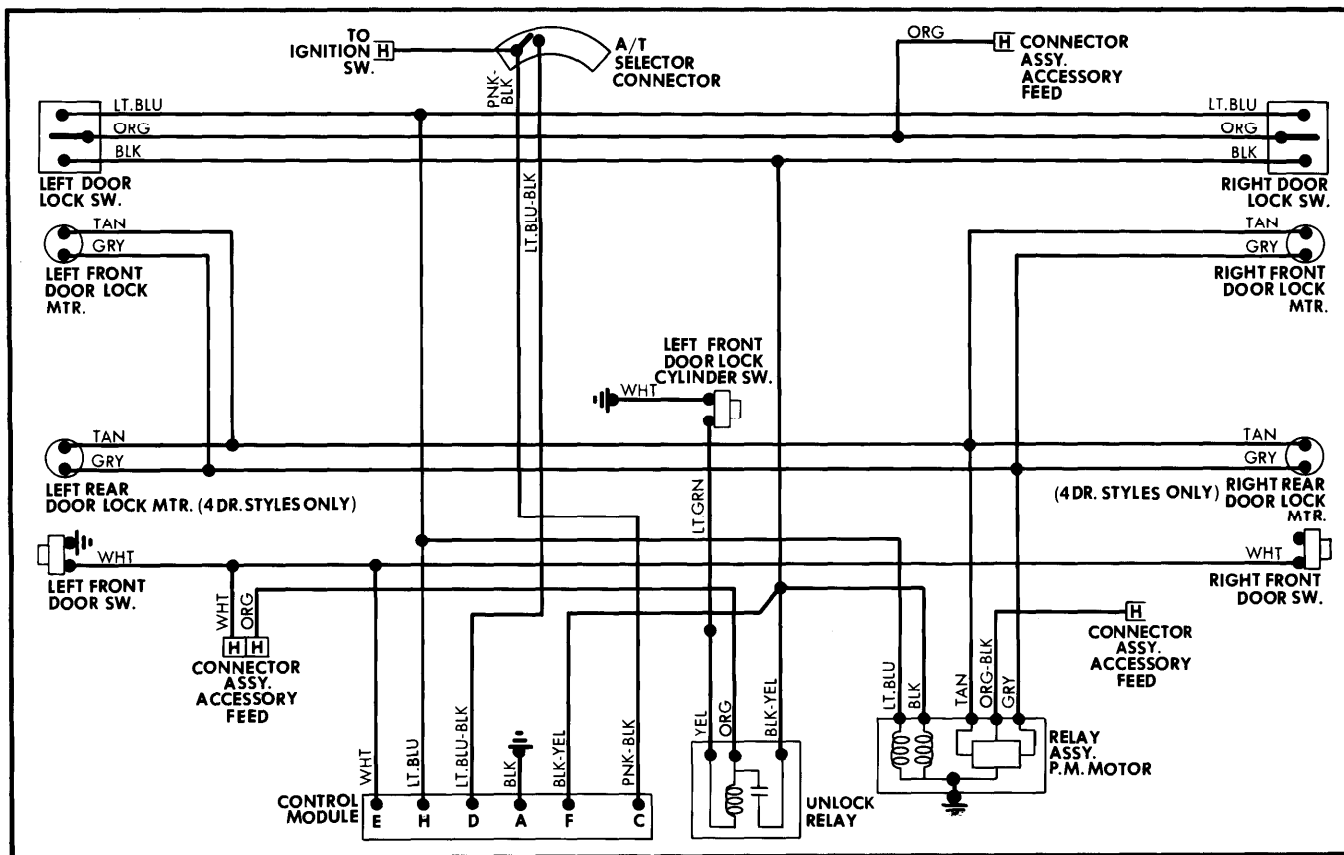

Fig. 2 Buick Automatic Door Lock Wiring Diagram

**Buick** – 1) With ignition on and transmission in "P", connect test lamp between ground and Lt. Blue/Black wire at module. If lamp is on, replace back-up light switch.

2) If lamp is off, check for open in Black/Yellow wire between module and motor relay. Repair wire if necessary. If wire is good, replace module printed circuit board.

### DOORS LOCK AUTOMATICALLY DO NOT UNLOCK AUTOMATICALLY

**Cadillac** – 1) With selector in "D" and all doors locked, touch test lamp to Lt. Blue/Black wire at module. If left door unlocks, repair Lt. Blue/Black wire between drive switch and module.

2) If door does not unlock, move test lamp to Black wire on module and move shifter to "P". If lamp comes on, test unlock relay. If not, replace module circuit board.

**Buick** – With ignition on and transmission in "P", touch test lamp to Lt. Blue/Black wire at module. If lamp is on, replace back-up light switch on steering column. If lamp is off, check continuity of Black/Yellow wire between module and motor relay. If okay, replace circuit board.

### DOORS LOCK AUTOMATICALLY WITH DOOR(S) OPEN & SELECTOR LEVER IN "DRIVE"

Check for the following conditions: Open in door jamb switch circuit (White wire); defective door jamb switch, open circuit in

White wire between module and courtesy light circuit. If none of these conditions exist, replace module printed circuit board.

### LOCKS DO NOT OPERATE AUTOMATICALLY OR FROM ARMREST SWITCHES

Check for opens or shorts in Orange/Black wire in the following circuits: Automatic Door Lock; Power Seat; Seat Back Lock.

## TESTING

### MOTOR LOCK RELAY TEST

**All Models** – 1) Be sure relay case is grounded during test. Check for power at Orange/Black wire. If no power, repair wire between fuse block and relay. Place test lamp probe on Lt. Blue wire at relay and press door switch to "LOCK". If lamp does not light, check switch, Orange wire and Lt. Blue wire.

2) If lamp was okay at Lt. Blue wire, test Black wire with switch in "UNLOCK" position. If lamp is off, check Black wire and switch. If lamp is on, test Tan wire with switch in "UNLOCK" position, then Gray wire with switch in "LOCK" position. If lamp does not light in either position, replace relay. If lamp is on in both cases, relay is good.

### LEFT DOOR UNLOCK RELAY

**Cadillac** – 1) With ignition on and shifter in "D", connect test lamp between ground and Black wire at relay. Move shifter to

# Door & Tailgate Locks

## GENERAL MOTORS AUTOMATIC – BUICK & CADILLAC (Cont.)

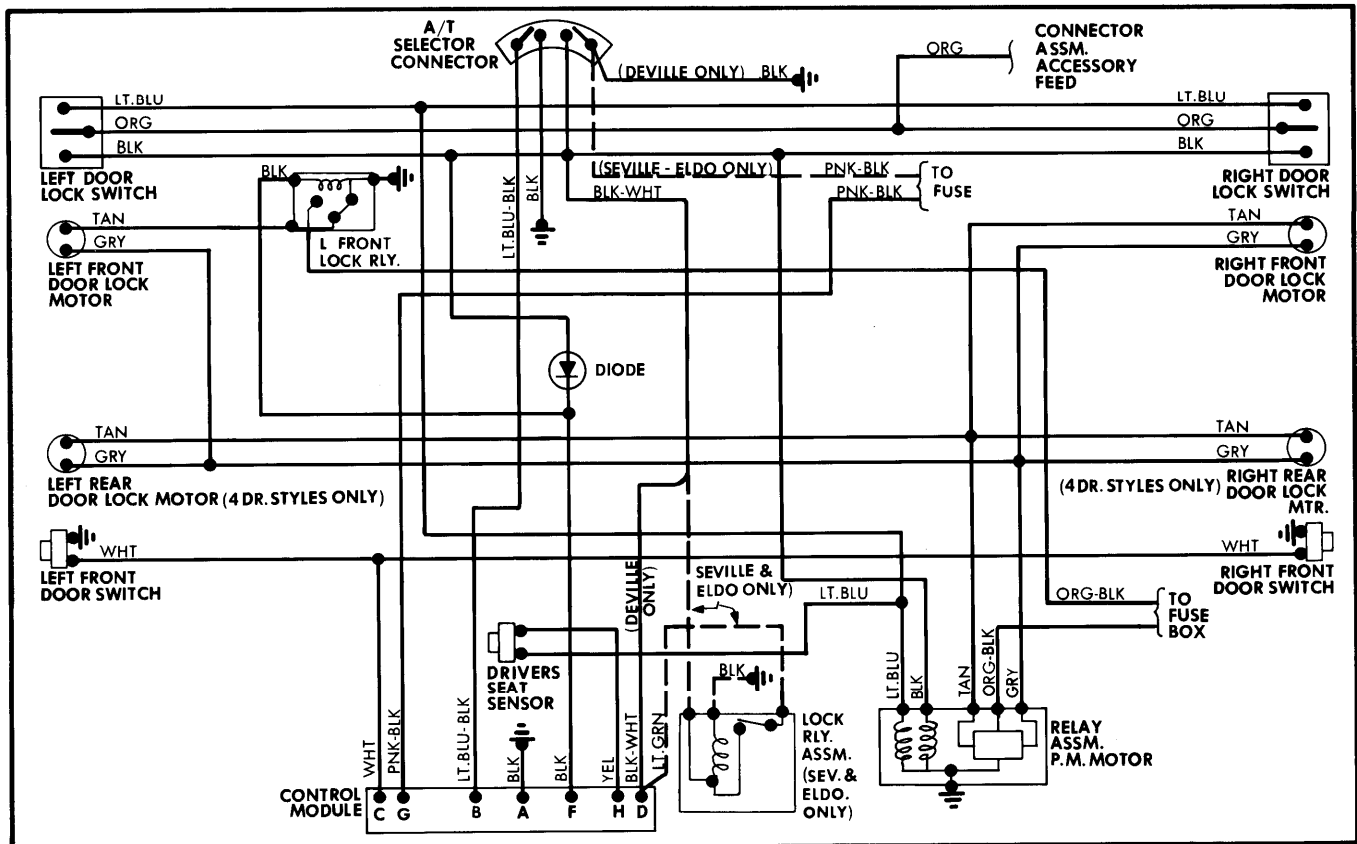

Fig. 3 Cadillac Automatic Door Lock Wiring Diagram

"P". If lamp does not light, check continuity of Black wire between relay and module. If lamp lights, move test lamp to Tan wire.

2) Move shifter from "D" to "P". If lamp is on, relay is good. If lamp does not light, test at Orange/Black wire. If lamp is on, replace relay. If not, check circuit breaker and Orange/Black wire.

### UNLOCK RELAY

**Buick** – 1) Lock all doors from arm rest switch. Connect test lamp between ground and Yellow wire at relay. If doors unlock, check door cylinder switch, switch ground, and wire to relay from switch.

2) If doors do not unlock, check for power at Orange wire on relay. If no power, repair Orange wire. Connect test lamp to Black/Yellow wire and actuate lock cylinder switch. If test lamp lights, repair Black/Yellow wire to motor lock relay. If lamp does not light, replace relay.

## REMOVAL & INSTALLATION

### MODULE & RELAYS

**Removal** – Remove kick panel. Remove module bracket and module. On Eldorado and Riviera, remove glove compartment and remove module.

**Installation** – To install, reverse removal procedure.

### PRINTED CIRCUIT BOARD

**Removal** – Lower module and remove relays. Remove fuse from fuse block, then open module case. Pry out circuit board with small screwdriver.

**Installation** – To install, reverse removal procedure insuring circuit board terminals are fully seated.

### BACK-UP LIGHT/NEUTRAL START SWITCH

**Removal** – Remove switch retaining screws from lower end of steering column.

**Installation** – To install, reverse removal procedure.

**NOTE** – Adjust switch as outlined in Automatic Transmission Servicing article in TRANSMISSION Section.

### SEAT SENSOR (CADILLAC)

A waffle type seat sensor switch is installed under the front seat trim cover.