

## CHRYSLER CORP.

Chrysler Corp.

## DESCRIPTION

The starter motor consists of 4 parallel fields, 4 brushes and a solenoid shifted, overrunning clutch. A 1.5 HP model is used on 225" (except LeBaron and Diplomat) and 318" engines. It has a gear reduction of 3.5-1. A 1.8 HP model is used on all other engines and has a 2.0-1 gear reduction.

The 2 motors appear identical, but have external and internal differences. The field frame and armature are larger on the 1.8 HP motor.

Both motors have a shock absorber clutch drive unit, which absorbs the initial shock of cranking and protects the clutch unit from engine backfires during cranking.

The starter system consists of 2 separate circuits, the supply circuit which provides the heavy current to the motor and the control circuit which actuates the solenoid. Unless otherwise noted, service and testing procedures are the same for both motors.

## TESTING

## STARTER CONTROLS

**NOTE** — Test solenoid and relay in order as described. Before performing any test, disconnect coil wire from distributor cap and secure to a good ground to prevent engine from starting.

**Starter Solenoid** — Connect a heavy jumper wire on starter relay between battery and solenoid terminals. If engine cranks, solenoid is good. Proceed to starter relay test. If it does not crank or solenoid chatters, check wiring and connectors from relay to starter (particularly starter terminal) for loose or corroded connections.

**Starter Relay** — With automatic transmission gear selector in "N" or "P" position, or clutch pedal depressed with manual transmission; connect a jumper wire on starter relay between battery and ignition terminals. If engine cranks, the starter relay is good. If engine does not crank, connect a second jumper wire to starter relay ground terminal and a good ground. If engine still does not crank, replace starter relay. If engine does crank, relay is functioning, but transmission linkage is out of adjustment, or neutral safety switch is defective (automatic transmission), or clutch neutral start switch is defective or out of adjustment (manual transmission).

## STARTER CRANKING CIRCUIT TESTS

Do not disconnect any terminals. With engine cranking, connect voltmeter at following locations: positive lead to battery positive post, negative lead to battery terminal on starter; positive lead to starter housing, negative lead to negative post on battery; positive lead to engine block, negative lead to battery ground cable. Each of these three connections should show a voltmeter reading of .2 volts or less. If any show more, clean or repair cables and connections in circuit.

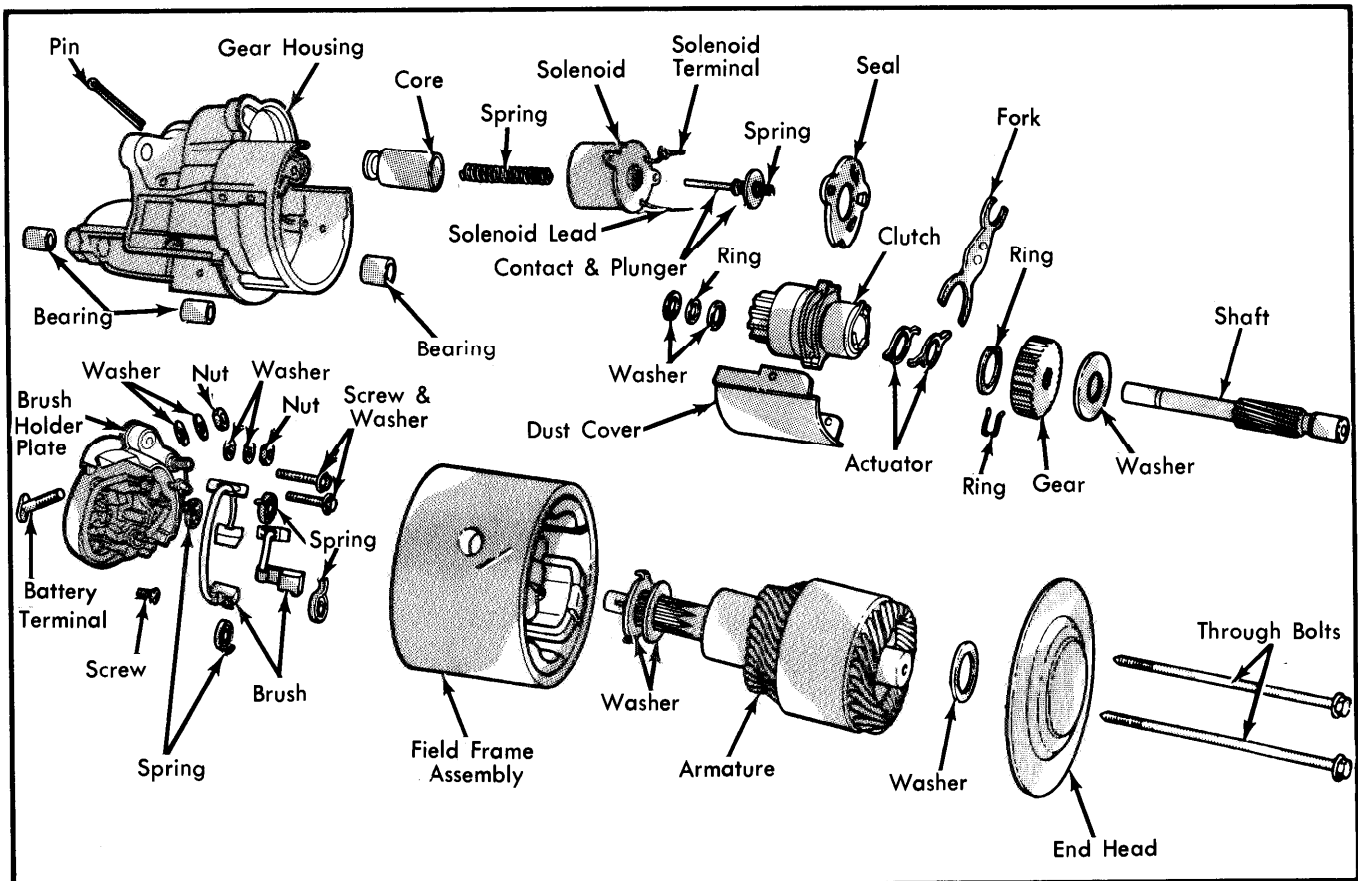

Fig. 1 Chrysler Starter Motor Exploded View

## CHRYSLER CORP. (Cont.)

### AMPERAGE DRAW TEST

**NOTE** — Engine should be up to operating temperature before performing this test. Heavy oil or a tight engine will increase starter draw amperage.

1) Connect suitable battery-starter tester leads to battery. Turn variable resistor control knob to off or zero position and crank engine long enough to read cranking voltage on voltmeter.

**CAUTION** — Do not crank engine excessively or starter may overheat.

2) Without cranking engine, turn variable resistor control knob on tester until voltmeter reads cranking voltage of previous test. With same voltage reading, amperage reading will be equivalent to starter current draw (see specifications).

### SOLENOID WINDINGS

1) To check hold-in circuit, connect solenoid to 6 volt DC power supply, with an ammeter in series. Connect positive lead of 6 volt battery to solenoid terminal and positive lead of ammeter to solenoid case. Attach negative battery lead to other ammeter terminal. Turn on circuit and check current draw.

2) To check pull-in coil, move the positive ammeter lead from solenoid case to solenoid lead terminal. Turn on circuit and check current draw.

3) If either winding test does not meet specifications, or if windings look burned or damaged, replace solenoid assembly.

### NO LOAD TEST (ON BENCH)

Connect a test ammeter and carbon pile rheostat in series with battery positive post and starter terminal. Connect a voltmeter across starter. Rotate carbon pile to full resistance position. Connect battery cable from battery negative post to starter frame. Adjust rheostat until battery voltage shown on voltmeter reads 11 volts. Amperage draw should be as shown in specifications

### LOCKED RESISTANCE TEST

Mount starter in test bench. Follow test equipment manufacturers instructions. With battery voltage adjusted to 4 volts, amperage draw should be as shown in specifications.

### Starter Specifications

Application	Amps.
Cranking Amperage Test	
Model No. 4111855 (1.5 HP) .....	165-180
Model No. 4111860 (1.8 HP) .....	180-200
Solenoid Amperage Test (6 volts @ 77°F)	
Pull-In Circuit .....	13-15
Hold-In Circuit .....	8-9
No Load Amperage Test	
Model No. 4111855 (3700 RPM minimum) .....	90
Model No. 4111860 (5700 RPM minimum) .....	90
Lock Resistance Amperage Test .....	475-550

### OVERHAUL

#### DISASSEMBLY

1) Remove through bolts and end head assembly. By pulling outwards, remove armature from gear housing and field frame assembly. Carefully pull field frame assembly from gear housing just far enough to expose terminal screw. Remove terminal screw, then completely remove field frame assembly.

2) Remove nuts and separate solenoid and brush plate assembly from gear housing. From smaller solenoid terminal, remove nut, steel washer, and insulating washer. Unwind solenoid lead wire from brush terminal. Remove screws attaching solenoid to brush plate.

3) On brush plate, remove nut from battery terminal, then remove terminal. From solenoid, remove solenoid contact and plunger assembly. Remove return spring from inside of solenoid moving core. Remove dust cover from gear housing.

**CAUTION** — Before removing retainer, which is under tension, place cloth over assembly to catch it as it flies off.

4) Release retainer clip that positions driven gear on pinion shaft. Remove pinion shaft "C" clip. Push shaft toward rear of housing and remove retainer ring and thrust washers, clutch and pinion assembly. Remove 2 shift fork nylon actuators as an assembly. Remove driven gear and friction washer. Pull shifting fork forward and remove solenoid moving core. Remove shifting fork retainer pin and shifting fork assembly.

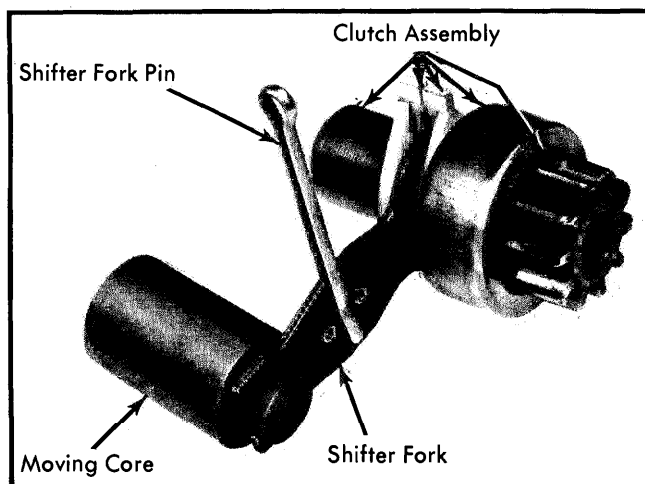

Fig. 2 Shift Fork and Clutch Assembly

#### PARTS REPLACEMENT & TESTING

**Brushes & Springs** — Replace if oil soaked or worn more than 1/2 length of new brushes. When resoldering shunt field and solenoid lead, use high temperature solder and resin flux (never acid core). Measure spring tension with spring scale hooked under spring near end. Pull on line parallel to edge of brush and note reading just as spring end leaves brush. Replace if tension is not within specifications.

Application	Tension
All .....	32-36 ozs.

## CHRYSLER CORP. (Cont.)

**Armature** — Check for shorted armature coils in a growler. Check for grounded coils by touching one test light probe to armature shaft and other probe to each commutator bar. Lamp should not light. If lamp lights, armature coils are grounded and armature should be replaced. Commutator should be smooth and clean, runout must not exceed .004". If runout is excessive, reface in a lathe removing only sufficient material to provide smooth even surface.

**Field Coil Assembly** — With field frame removed from starter, drill out rivet attaching field coil lead and ground leads to field frame. Then insulate leads from frame. Test for ground with 110V test lamp by touching one probe to series coil lead and other probe to field frame. Lamp should not light. If lamp lights, field coils are grounded. Replace field coils and field frame as an assembly.

**Starter Shaft Bushings** — Inspect shaft bearing surfaces for wear, check bushing wear by inserting shaft and checking sideplay. Replace end head if bushing is worn (furnish as an assembly). Replace other bushings with Tool C 3944 or equivalent and adapters. Service bushings are presized and do not require burnishing or reaming.

**Starter Clutch Unit** — Never immerse pre-lubricated clutch unit in cleaning solvent. Pinion should rotate smoothly (not easily) in one direction and should not rotate in the other. If not functioning properly, or if pinion is worn, chipped or burred, replace clutch unit.

**CLEANING**

Do not immerse parts in cleaning solvent. Clutch outer housing and pinion gear may be cleaned with a cloth moistened with cleaning solvent then wiped dry. Clean all corrosion from solenoid assembly and inside of solenoid housing (these are part of solenoid hold-in ground circuit and must be clean). Clean terminal contacts and contactor with crocus cloth.

**REASSEMBLY**

1) Make sure shift fork plates have approximately  $\frac{1}{16}$ " side movement, lubricate sparingly between plates with SAE 10 engine oil. Position shift fork in housing bending one tip of pin at 15° angle away from housing. Fork and pin must operate freely. Install solenoid moving core and engage shifting fork.

2) Start pinion shaft into drive housing. Install friction washer, drive gear, clutch and pinion assembly, thrust washer, retaining ring and thrust washer. Complete installation of pinion shaft, making sure shifting fork properly engages clutch actuators. The friction washer must be positioned on shoulder of splines of pinion shaft before driven gear is positioned. Install driven gear snap ring, pinion shaft "C" clip, and starter solenoid return spring (into bore of movable core).

3) Inspect starter solenoid switch contacting washer for burned condition, reversing washer if necessary. Install solenoid contact plunger assembly into solenoid. Make sure contact spring is positioned on shaft of solenoid contact plunger assembly. Place battery terminal stud in brush holder. Inspect condition of contacts in brush holder plate. Replace brush holder with brushes and contacts as an assembly if burned. Position seal on brush holder plate.

4) Start solenoid lead wire through hole in brush holder, install solenoid stud, insulating washer, flat washer and nut. Wrap lead wire tightly around brush terminal post, solder with high temperature resin core solder and resin flux. Install brush holder to solenoid attaching screws. Enter solenoid coil and brush plate assembly into starter gear housing, install and tighten attaching nuts.

5) Position brushes with armature thrust washer, so brushes rest on washer tabs. Washer will hold brushes out and facilitate armature installation. Install brush terminal screw.

6) Position field frame in correct position on gear housing and install armature in field frame and gear housing. Carefully engage splines of shaft with reduction gear by rotating armature slightly. Install thrust washer on armature shaft. Position starter end head assembly and tighten through bolts securely.