

## AMERICAN MOTORS – CONCEALED

### Pacer

### DESCRIPTION

Wiper motor is a two speed permanent magnet depressed park type, with bush end plate at one end of housing and a gear housing at the other end. Park switch is located in gear cover and park mechanism is located in output arm. As optional equipment, intermittent operation of wiper motor is controlled by a variable resistor in wiper switch in conjunction with an electronic governor. This allows for a variable pause between wiping cycles.

### TESTING

#### WIPER MOTOR CURRENT DRAW

Perform test with motor on car and linkage disconnected or on bench. Connect ammeter (see illustration). Connect a jumper wire from battery to low speed terminal on motor end plate and read current draw. Move jumper to high speed terminal and read current draw. In both cases, current draw should not exceed 3.5 amps.

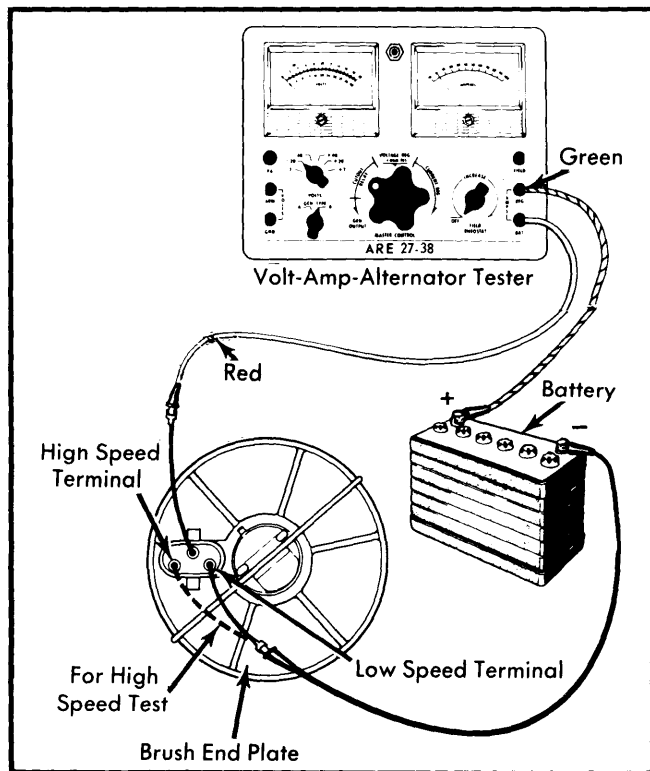

Fig. 1 Meter Connections for Motor Current Draw Test

#### WIPER CONTROL SWITCH TESTS

1) Check continuity using a test lamp or ohmmeter. Continuity should exist between various switch positions as shown in Fig. 2, and in Wiper Switch Continuity Test Charts.

2) Variable resistance between "F" and "E" must be checked with an ohmmeter. The resistance controls governor operation

for intermittent wipe. If intermittent wipe is inoperative, but system will operate at high and low speeds, this resistance should be checked. With switch knob rotated to full counter-clockwise position, ohmmeter should indicate 8,000 to 13,000 ohms. As switch is rotated in a clockwise direction, resistance should decrease to 100 to 900 ohms.

3) If continuity and resistance do not exist as specified, replace switch.

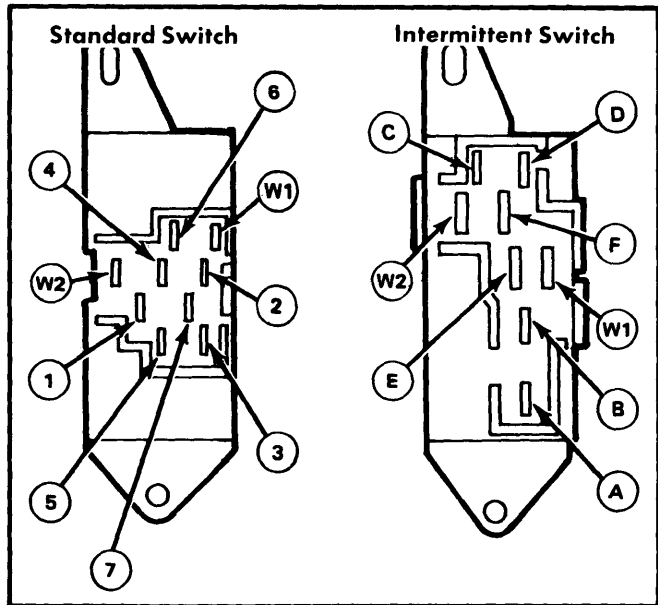

Fig. 2 Wiper Control Switch Terminal Identification

#### Wiper Switch Continuity Tests

Standard Wiper	Switch Position	Terminal Continuity
Pacer	Off (Park)	1-5, 3-7
	Low	1-4, 2-7
	High	1-4, 2-6
	Wash	W1-W2
Intermittent Wiper	Switch Position	Terminal Continuity
Pacer	Off (Park)	A-E
	Intermittent	B-E-F
	Low	B-E-F-C
	High	D-B-F-C
Wash	W1-W2	

#### WIPER MOTOR PARK TEST

Operate motor and stop motor when output arm is about 90° past park position for this test. With jumper wires connected as shown in illustration, the motor output arm should move in following cycle: Rotate in normal direction, then reverse rotation for about 10-15°, and stop rotation while crank arm is moved outward in a semicircular motion. Then finally stop in park position with current draw reducing to zero.

# Wiper/Washer Systems

## AMERICAN MOTORS – CONCEALED (Cont.)

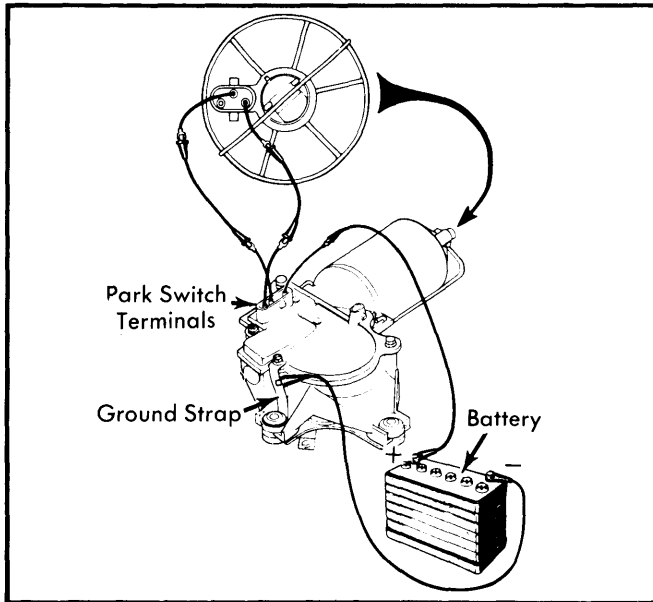

**Fig. 3 Meter Connection for Wiper Motor Park Test**

### REMOVAL & INSTALLATION

#### WIPER ARM, PIVOT SHAFT & LINKAGE DRIVE ARM

**Removal** – 1) Remove wiper blade and arm as an assembly by lifting blade away from glass and pushing outward on tab on wiper arm release latch at pivot shaft.

2) Disconnect linkage drive arm from motor output arm crankpin by removing retaining clip. Remove pivot shaft assembly.

**Installation** – To install, reverse removal procedure.

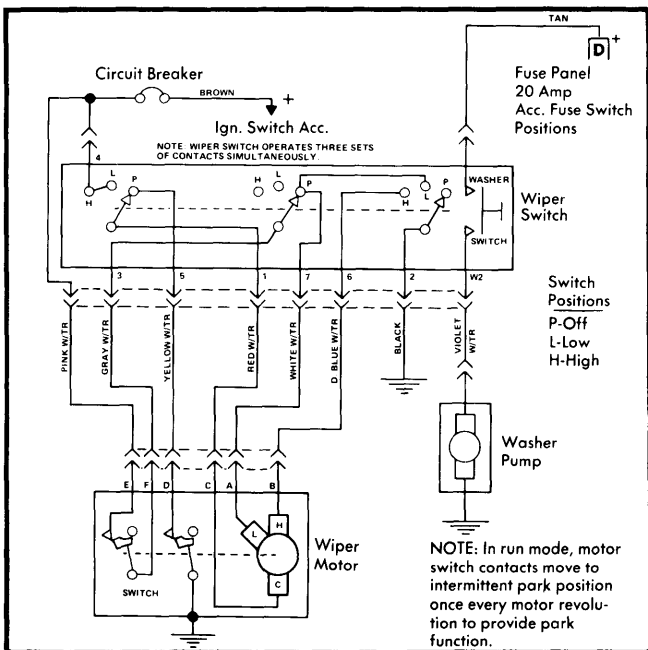

**Fig. 4 AMC Pacer Concealed Standard Wiper System Wiring Diagram**

#### WIPER MOTOR

**Pacer** – Remove vacuum canister and bracket. Disconnect linkage drive arm by removing retaining clip from motor output arm crankpin. Remove nuts and screws retaining heater housing and pull heater housing away from area. Remove wiper motor plate retaining screws and remove motor from cowl. Disconnect motor electrical leads and separate motor from plate by removing retaining screws. To install, reverse removal procedure, insuring that output arm is in the park position.

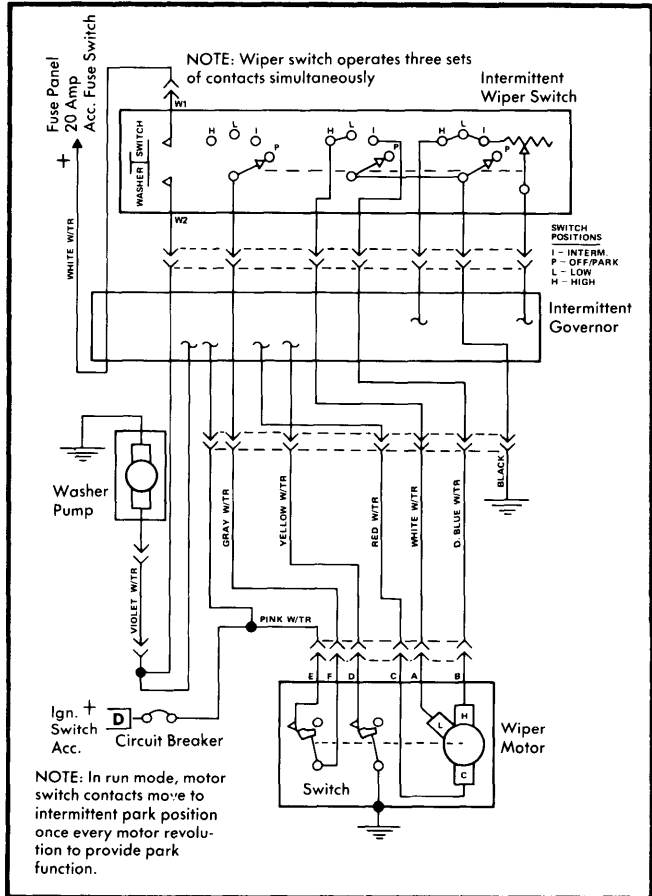

**Fig. 5 AMC Pacer Concealed Intermittent Wiper System Wiring Diagram**

### DISASSEMBLY & ASSEMBLY

#### WIPER MOTOR

**NOTE** – Motor is serviced as an assembly, or in major subassemblies.

**Cover and Switch** – Remove cover retaining screws and replace cover and switch as an assembly, insuring ground strap is installed under a cover retaining screw.

**Brush End Plate** – Note position of bale retainer and pry off using a screwdriver. Remove end plate and plug. Replace plate and brushes as an assembly using a fine wire probe through hub opening to position brushes on commutator. Rotate end plate so key aligns with notch and assemble plug. Carefully install bale retainer.