

## GENERAL MOTORS

### MODEL IDENTIFICATION

References will be made in the following text to certain body types. The table below will identify these body types by GM division and car name. Only cars with power windows as standard or optional equipment are listed.

GM Division	Body Type	Car Name
Buick	A	Century, Regal
Chevrolet	A	El Camino, Malibu, Monte Carlo
Oldsmobile	A	Cutlass
Pontiac	A	LeMans, Grand Prix
Buick	B	Estate Wagon, LeSabre
Chevrolet	B	Impala, Caprice
Oldsmobile	B	Delta 88
Pontiac	B	Bonneville, Catalina
Buick	C	Electra
Cadillac	C	Fleetwood, DeVille
Oldsmobile	C	Ninety Eight
Cadillac	D	Limousine
Buick	E	Riviera
Cadillac	E	Eldorado
Oldsmobile	E	Toronado
Chevrolet	F	Berlinetta, Camaro
Pontiac	F	Firebird
Buick	H	Shyhawk
Chevrolet	H	Monza
Pontiac	H	Sunbird
Cadillac	K	Seville
Buick	X	Skylark
Chevrolet	X	Nova
Oldsmobile	X	Omega
Pontiac	X	Phoenix
Chevrolet	Y	Corvette

### DESCRIPTION

#### DOOR & POWER VENT WINDOWS

Window regulators are individually powered by a reversible electric motor located in each door. The motor which is secured to the regulator assembly, contains an internal circuit breaker and a self-locking gear drive. Two way switches, located on each door, with a master control switch located on left door, control window operation.

#### CIRCUIT BREAKER

Circuitry and wiring for power equipment is protected by a 30 amp circuit breaker of the plug in type. It is mounted on the fuse panel for all GM divisions.

### CONTROL SWITCHES

In addition to individual control switches adjacent to individual windows, a master control switch is mounted either in the arm rest or on the trim pad. Master switch is a four button switch for front and rear windows.

#### BLOCKOUT SWITCH (CADILLAC ONLY)

A two position switch is installed on left front door armrest. Switch should be left in "NORMAL" position to permit normal operation from all switch positions. In "LOCK" position, the windows will operate only from master control switch.

#### IGNITION RELAY

All "F" and "X" styles use a relay in the window circuit to prevent window operation until ignition switch is turned on. The feed circuit for all other styles is controlled directly through the ignition switch. The relay is located on the left shroud side panel on "X" body. Relay for "F" body is located at steering column lower support.

#### ACCESSORY JUNCTION BLOCK

Located on the reinforcement at the left shroud and used to supply current to power operated circuits. Current is supplied to junction block from the circuit breaker. The power window harness plugs into the junction block.

## TROUBLE SHOOTING

#### WINDOWS WILL NOT OPERATE WITH IGNITION ON

Open circuit or short in power feed circuit. Switch defective.

#### RIGHT REAR WINDOW WILL NOT OPERATE WITH EITHER MASTER OR WINDOW SWITCH BUT LEFT REAR WINDOW OPERATES

Open circuit or short between rear window harness and front window harness. Open circuit or short in right rear window switch or motor circuit. Binding in window channels. Defective window motor.

#### RIGHT WINDOWS OPERATE WITH MASTER SWITCH BUT WILL NOT OPERATE WITH RIGHT CONTROL SWITCHES, LEFT WINDOWS OPERATE

Open circuit or short in front harness feed circuit.

## TESTING

#### CIRCUIT BREAKER

Check power feed to circuit breaker, with no power available, feed wire is open or shorted. Test breaker output terminal, if power fails, breaker is inoperative.

#### IGNITION RELAY

Test relay feed Orange/Black wire for voltage, without voltage available, check wire leading to circuit breaker. Turn ignition to "ON" and test relay Pink/Black Stripe wire terminal. If power fails, test relay coil voltage Pink wire terminal. If power is now available, replace relay. If power fails, check circuit along Pink wire and check fuse.

## GENERAL MOTORS (Cont.)

### MASTER CONTROL SWITCH

Check power feed Pink wire at switch, if power fails, test wire between relay and master switch.

**NOTE** – If power fails at master switch on Cadillac models, check blockout switch.

### BLOCKOUT SWITCH (CADILLAC ONLY)

With ignition "ON", test blockout switch using a jumper wire between the RED-WHITE wire and PINK-BLACK wire terminals. Operate control switches, if windows operate with jumper, but not with blockout switch, the switch is defective.

### WINDOW CONTROL SWITCH

- 1) Connect one lead of test lamp to switch connector feed wire and ground other lamp lead. If lamp does not light, an open or short circuit exists between switch and power source.
- 2) Insert one end of a jumper wire in switch connector and other end of jumper to motor lead in connector. Repeat procedure for motor lead terminal. If motor operates with jumper wire but does not operate with switch, replace switch.

### WINDOW SWITCH TO WINDOW MOTOR HARNESS

Disconnect harness connector from motor. Insert one end of a jumper wire in switch connector and other end of jumper wire to motor lead in connector. Using a test lamp, check for current at motor connector. If lamp does not light, switch to motor harness which is shorted or has an open circuit. Check other terminal using same procedure.

### WINDOW MOTOR

Check power feed wire to motor terminals, if power is available, check motor ground. Inspect window regulator and channels for possible binding. Connect a jumper wire to power source and one of the motor terminals, then connect to the other motor terminal. Motor should operate window up and down, if not, replace motor.

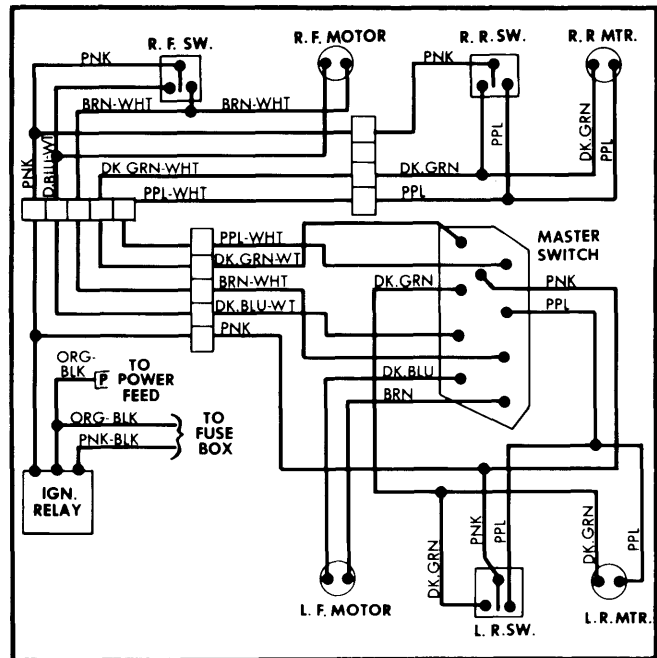

Fig. 2 "X" Body Four Door Model with Ignition Relay Power Window Wiring Diagram (Two Door Models Similar)

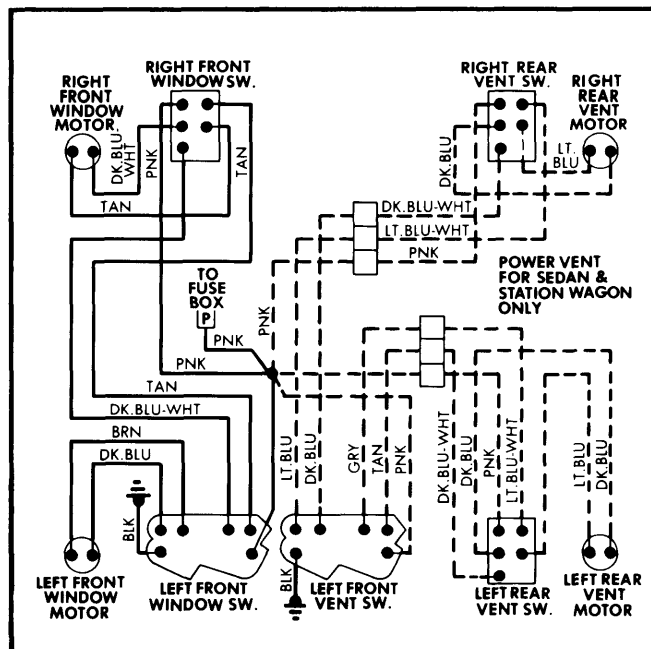

Fig. 1 "A" Four Door Models ("B", "C" and "K" Models Similar)

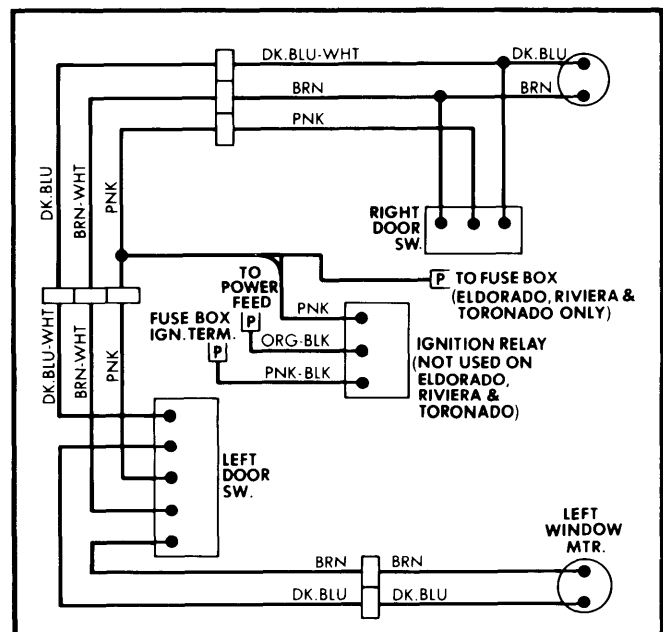

Fig. 3 "F" and "X" Body Power Window Wiring Diagram ("A", "B", "C" and "E" Two Door Models Similar)

## GENERAL MOTORS (Cont.)

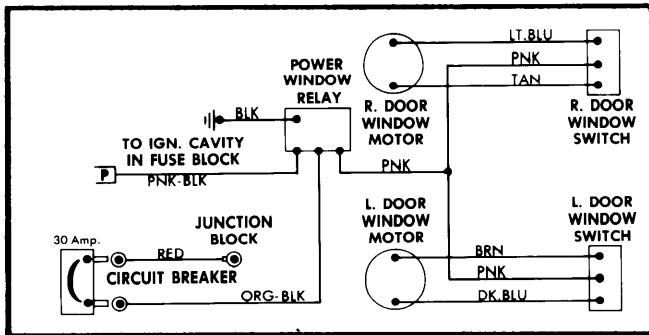

Fig. 4 Corvette Power Window Wiring Diagram

## REMOVAL &amp; INSTALLATION

## REGULATOR &amp; MOTOR (CORVETTE)

**Removal** – 1) Remove trim panel, position window in up position, remove glass retainer assembly bolts and stationary horizontal channel retaining bolts.

**CAUTION** – Do not remove motor from regulator at this time.

2) Remove lower bolt retaining front glass channel. Remove motor electrical connection. Adjust front channel outward to provide clearance for regulator removal, and collapse regulator linkage to elongated position.

3) Depress front channel outward and slide regulator assembly forward and rearward through access hole.

4) Place regulator in vise, electrically operate motor until semi-circular hole in sector gear aligns with one of the two welded nuts on mounting plate. Insert a bolt through welded nut and hole in sector gear. Separate motor from regulator.

**Installation** – To install, reverse removal procedures. Remove lock bolt from sector gear if motor and regulator were separated.

REGULATOR MOTOR (ALL STYLES)  
GLASS INTACT & ATTACHED TO REGULATOR

**Removal** – 1) Remove door trim and watershield. Disconnect harness connector at motor. Refer to template illustrations for correct template for locating window motor to regulator attaching bolts. Use window regulator to door inner panel attaching bolts as reference points.

**NOTE** – On "X" closed style rear doors not equipped with regulator counterbalance spring, tape window to frame to prevent glass from dropping when regulator motor is removed.

2) Align regulator bolt location specified on template with appropriate regulator attaching bolts on door. Secure template in place with tape. Using a center punch, dimple door inner panel at center of each  $\frac{3}{4}$ " weld to be drilled as indicated on template. Using a  $\frac{3}{4}$ " hole saw, drill three  $\frac{3}{4}$ " motor-to-regulator attaching bolt access holes.

3) Remove motor attaching bolts through the  $\frac{3}{4}$ " access holes, and remove motor from panel.

**NOTE** – Window regulator lift arm is under tension of counterbalance spring and weight of window assembly prevents lift arm from moving. If necessary, window can be moved manually to clear access holes.

**Installation** – To install, reverse removal procedure noting that after replacing motor and prior to trim installation, waterproof tape must be applied to seal any hole outside of water deflector area.

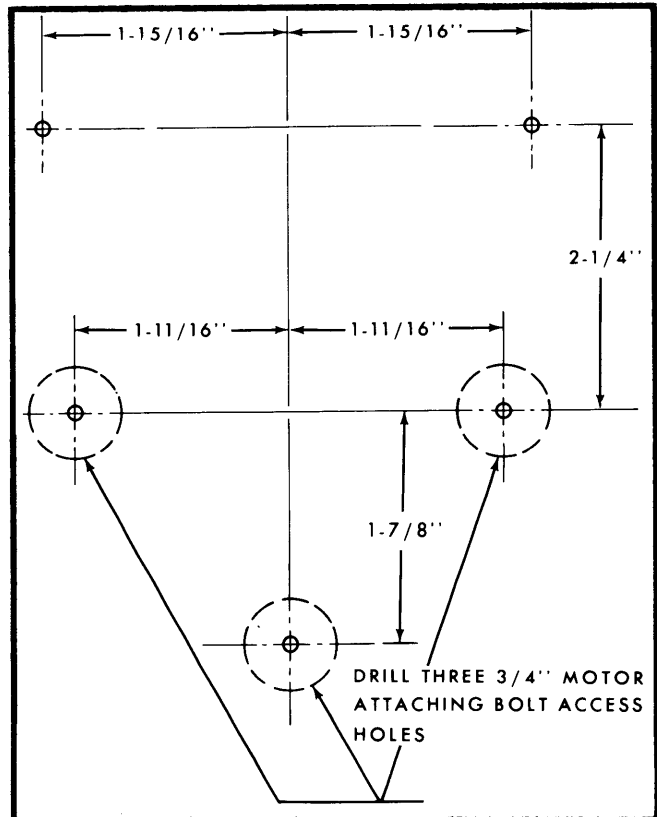

Fig. 5 Alignment Template, "E" Body

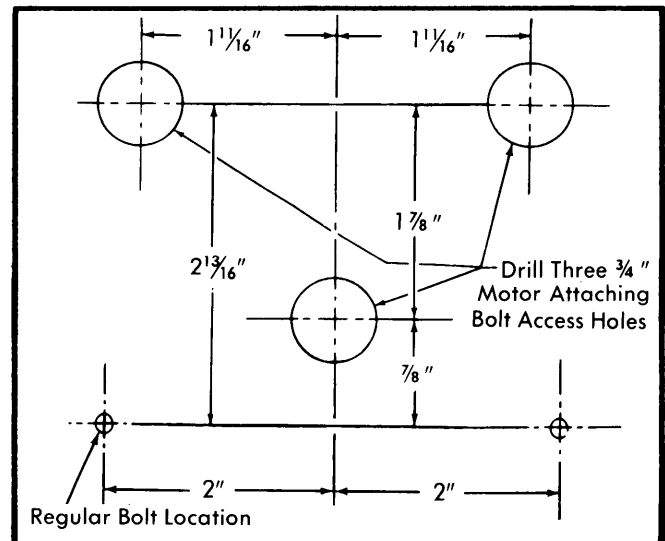

Fig. 6 Alignment Template, "F" Body

## GENERAL MOTORS (Cont.)

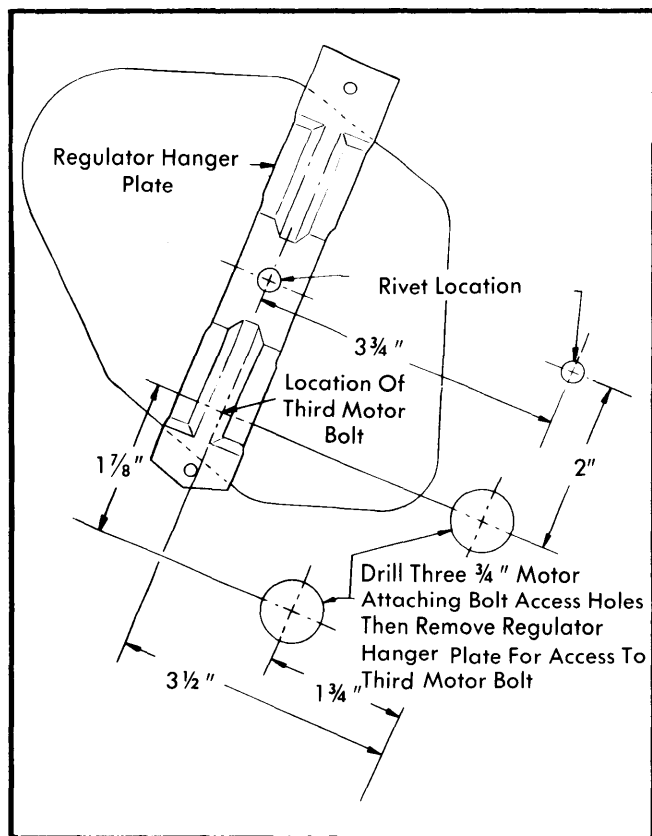

Fig. 7 Alignment Template, "X" Body (Front Door)

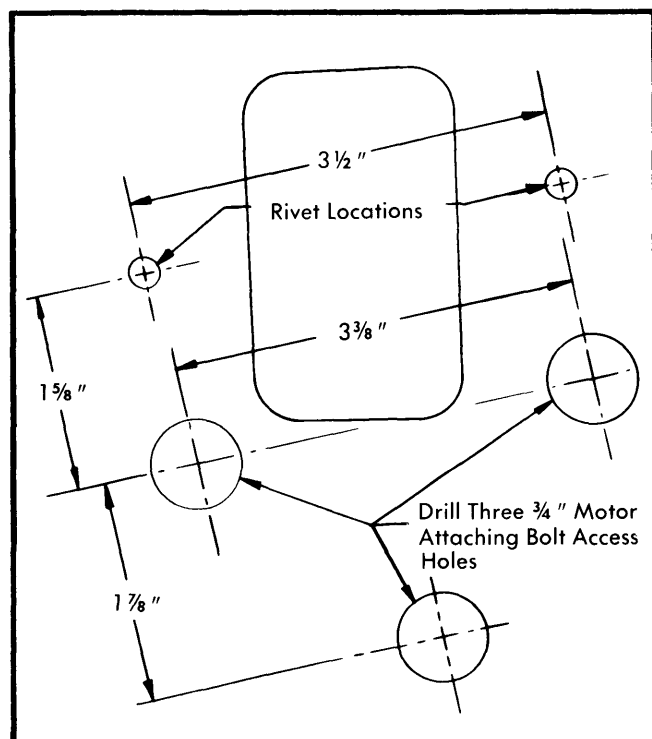

Fig. 8 Alignment Template, "X" Body (Rear Door)

### REGULATOR MOTOR ("A" "B", "C", & "K" FRONT DOORS) GLASS INTACT & ATTACHED TO REGULATOR

**CAUTION** – Regulator lift arms are under tension from counterbalance spring and weight of glass is required to neutralize spring during motor removal. Two motor removal procedures are given for use depending on condition of glass.

**Removal** – Remove regulator from motor as follows: Remove upper and lower door trim assemblies and watershield. Use a  $\frac{7}{16}$ " socket to remove motor attaching bolts from outside of motor. Lift motor to gain access to wire harness, disconnect harness and remove motor.

**Installation** – To install motor, reverse removal procedure. Lubricate motor drive gear and sector teeth with suitable grease (cold weather approved to a minimum of  $-20^{\circ}\text{F}$ )

### REGULATOR MOTOR (ALL MODELS) GLASS BROKEN OR NOT ATTACHED TO REGULATOR

**Removal** – 1) Remove motor and regulator as an assembly. See *Front Door Window Regulator Removal & Installation*.

2) After removing motor and regulator from door, lock sector gear before removing motor from regulator by drilling a  $\frac{1}{8}$ " hole through regulator sector gear and back plate. Install a suitable sheet metal screw  $\frac{3}{4}$ " in length in drilled hole to lock gear position.

**NOTE** – It is not necessary to lock sector gear on "X" model front and rear doors not equipped with regulator counterbalance springs.

3) Remove motor attaching screws and remove motor from regulator.

**Installation** – To install, reverse removal procedure. Lubricate motor drive gear and sector teeth with suitable grease (cold weather approved to minimum of  $-20^{\circ}\text{F}$ ).

### FRONT DOOR WINDOW REGULATOR

**NOTE** – For body identification see *Model Identification Chart*.

**CAUTION** – To prevent personal injury after removing regulator and motor assembly, lock sector gear to back plate before removing motor as follows: Drill a  $\frac{1}{8}$ " hole through sector gear and back plate. Do not drill closer than  $\frac{1}{2}$ " to edge of sector gear. Install a suitable metal screw ( $\frac{3}{4}$ " in length) to lock gear, then remove motor.

**Removal ("A" Body Closed Style Door)** – 1) Remove upper and lower door trim panel and watershield. Prop window in full up position using rubber door stops between window and door inner panel. Mark location and remove inner panel cam attaching bolts.

## GENERAL MOTORS (Cont.)

2) Disconnect wire harness at motor. Drive out regulator mounting rivet center pins and drill out rivets using  $\frac{1}{4}$ " drill.

3) Slide front regulator upper balance arm off sash cam, then slide rear lift arm forward off sash cam. Slide regulator rearward and remove through lower rear access hole.

**Installation** – To install, reverse removal procedure using "U" nuts (Part No. 3916700) and screws to attach regulator to back plate.

**Removal ("A" Body Hard Style Door)** – 1) Remove upper and lower door trim panel and watershield. Prop window in full up position by inserting a rubber door stop between window and door inner panel.

2) Mark locations and remove inner panel cam attaching bolts, remove rear guide upper and lower attaching bolts and remove guide.

3) Mark location and remove down travel stop, front window glass stabilizer plate and disconnect wire harness at motor.

4) Drive out regulator mounting rivet center pins and drill out rivets using  $\frac{1}{4}$ " drill. Remove front lower sash channel cam-to-glass attaching nut. Slide regulator forward until front upper balance arm roller is out of sash channel cam.

5) Lift regulator to clear roller on glass and slide rear lift arm rearward until it disengages from rear of sash channel cam. Remove regulator through rear access hole.

**Installation** – To install, reverse removal procedure using "U" nuts (Part No. 3916700) and screws to attach regulator to back plate.

**Removal ("B", "C", "E" Body Styles Two Door Hardtop)** – 1) Remove door trim panel and watershield. Remove inside locking rod as follows: Slide front locking rod-to-door inner panel plastic retainer toward rear of door. Disengage rod from lock, and lower locking rod through beltline to remove.

2) Lower window to half open position. Drive out regulator mounting rivet center pins and drill out rivets using  $\frac{1}{4}$ " drill. Disengage regulator lift arm roller from lower sash channel cam and prop window in full up position. Rotate regulator assembly clockwise so that motor portion of regulator comes out access hole first. To install, reverse removal procedure using "U" nuts (Part No. 3916700) and screws to attach regulator to back plate.

**Installation** – To install, reverse removal procedure using "U" nuts (Part No. 3916700) and screws to attach regulator to back plate.

**Removal ("B" & "C" Body Four Door Styles)** – 1) Remove upper and lower portion of door trim panel and watershield. Remove front and rear window up-travel stops. Loosen front and rear window stabilizer strips.

2) With window in  $\frac{3}{4}$  down position, remove lower sash channel cam-to-glass attaching nuts. Remove window by lifting straight up and aligning rollers with notches provided in door inner panel. Disconnect wire harness connector at regulator motor. Drive out regulator mounting rivet center pins and drill out rivets using  $\frac{1}{4}$ " drill. Remove regulator.

**Installation** – To install, reverse removal procedure using "U" nuts (Part No. 3916700) and screws to attach regulator to back plate.

**Removal ("H" & "X" Body)** – 1) Remove door trim and panel watershield. Prop window in full up position and hold in place with cloth backed tape applied over door frame. Mark location and remove inner panel cam attaching bolts.

2) Disconnect electrical connection at window motor. Using a center punch, drive out rivet center pin. Using a  $\frac{1}{4}$ " drill, drill out all regulator retaining rivets. Remove regulator.

**Installation** – To install regulator, reverse removal procedures. Attach regulator to inner panel using  $\frac{1}{4}$  - 20X $\frac{1}{2}$ " screws and "U" nut (Part No. 3916700) over attaching hole in back plate.

## REAR DOOR WINDOW REGULATOR

**NOTE** – For body identification see Model Identification chart.

**CAUTION** – To prevent personal injury after removing regulator and motor assembly, lock sector gear to back plate before removing motor as follows: Drill a  $\frac{1}{8}$ " hole through sector gear and back plate. Do not drill closer than  $\frac{1}{2}$ " to edge of sector gear. Install a suitable metal screw ( $\frac{3}{4}$ " in length) to lock gear, then remove motor.

**Removal ("A" Body Hardtop Door)** – 1) Remove upper and lower door trim assembly, and watershield. Loosen trim support retainer attachments. Remove front and rear-up travel stops. Remove lower sash guide plate assembly-to-glass attaching stud nuts. Tilt upper edge of glass inboard to disengage glass from guide plate. Remove window by lifting straight up.

2) Drive out regulator mounting rivet center pins and drill out rivets using  $\frac{1}{4}$ " drill. Disengage regulator lift arm from sash plate guide cam. Remove upper and lower guide tube assembly attaching screws, and remove guide tube and lower sash guide plate assembly from door. Disconnect wire harness and remove regulator from door.

**Installation** – To install, reverse removal procedures using "U" nuts (Part No. 3916700) and screws to attach regulator to inner panel.

**Removal ("B" Body Closed Style Doors)** – 1) Remove upper and lower portion of door trim panel and watershield. Lower window to a  $\frac{3}{4}$  down position, remove lower sash channel cam-to-glass attaching stud nuts.

2) While supporting glass, disengage cam from rollers on regulator lift balance arms and remove cam. Raise window to full up position and secure with cloth backed body tape.

3) Remove inner panel cam attaching bolts. Drive out regulator mounting rivet center pins and drill out rivets using  $\frac{1}{4}$ " drill. Remove regulator out through access hole.

**Installation** – To install, reverse removal procedures using "U" nuts (Part No. 3916700) and screws to attach regulator to inner panel.

## GENERAL MOTORS (Cont.)

**Removal ("B" & "C" Body Hardtop, Exc. Fleetwood) — 1)** Remove upper portion of door trim panel and watershield. Prop window in full up position, remove center guide cam upper and lower attaching bolts. Pull guide downward to disengage from window lower sash guide plate assembly. Remove guide through access hole.

**Installation** — To install, reverse removal procedures using "U" nuts (Part No. 3916700) and screws to attach regulator to inner panel.

**Removal ("C" Body Cadillac Fleetwood) — 1)** Remove upper and lower portion of door trim assembly and inner panel watershield. Drive out regulator mounting rivet center pins and drill out rivets using  $\frac{1}{4}$ " drill.

**2)** Disengage regulator lift arm roller from lower sash channel cam and prop window in full up position. Rotate regulator assembly clockwise so motor portion of regulator assembly comes out first.

**Installation** — To install, reverse removal procedures using "U" nuts (Part No. 3916700) and screws to attach regulator to inner panel.

**Removal ("B" Body Sedan) — 1)** Remove door trim panel and watershield. Lower window to within 2" of full down position. Insert rubber wedge door stop between window and inner panel. Remove lower sash channel to cam-to-glass attaching stud nuts. Disengage cam from rollers on regulator lift and balance arms and remove cam.

**2)** Prop window in full up position and hold in place with cloth backed tape applied over door frame. Mark location and remove inner cam attaching bolts. If regulator is attached with bolts, remove bolts and rotate regulator 90° to remove through access hole. Disconnect motor electrical connector and remove motor and regulator.

**3)** If regulator is attached with rivets, drive out rivet center pin with a center punch. Using a  $\frac{1}{4}$ " drill, drill out all

regulator retaining rivets. Disconnect motor electrical connector, rotate motor and regulator 90° and remove through access hole.

**Installation** — To install, reverse removal procedures using "U" nuts (Part No. 3916700) and screws to attach regulator to back plate.

**Removal ("X" Body) — 1)** Remove door trim panel and watershield. Remove locking rod link bolt and disconnect locking rod at lock. Place window at full up position and hold in place with cloth backed tape applied over door frame.

**2)** Disconnect electrical connection at window motor. Using a center punch, drive out rivet center pin. Using a  $\frac{1}{4}$ " drill, drill out all regulator retaining rivets. Remove regulator.

**Installation** — To install, reverse removal procedures. If rivets were used to originally secure regulator to back plate, use "U" nuts (Part No. 3916700) and screws to attach regulator to back plate.

## REAR QUARTER WINDOW REGULATOR

**CAUTION** — To prevent personal injury after removing regulator and motor assembly, lock sector gear to back plate before removing motor as follows: Drill a  $\frac{1}{8}$ " hole through sector gear and back plate. Do not drill closer than  $\frac{1}{2}$ " to edge of sector gear. Install a suitable metal screw ( $\frac{3}{4}$ " in length) to lock gear, then remove motor.

**Removal (Hardtop W/Rear Swing Out Window) — 1)** Remove upper and lower quarter trim assembly and watershield. Disconnect electrical connection at motor.

**2)** Drive out regulator mounting rivet center pins and drill out rivets using  $\frac{1}{4}$ " drill. Disengage regulator lift arm roller from quarter window lower sash guide plate.

**Installation** — To install, reverse removal procedures using "U" nuts (Part No. 3916700) and screws to attach regulator.